



THE UNIVERSITY *of* EDINBURGH

Edinburgh Research Explorer

## Smart Decentralized Control of DG for Voltage and Thermal Constraint Management

**Citation for published version:**

Sansawatt, T, Ochoa, L & Harrison, G 2012, 'Smart Decentralized Control of DG for Voltage and Thermal Constraint Management', *IEEE Transactions on Power Systems*, vol. 27, no. 3, pp. 1637-1645.  
<https://doi.org/10.1109/TPWRS.2012.2186470>

**Digital Object Identifier (DOI):**

[10.1109/TPWRS.2012.2186470](https://doi.org/10.1109/TPWRS.2012.2186470)

**Link:**

[Link to publication record in Edinburgh Research Explorer](#)

**Document Version:**

Peer reviewed version

**Published In:**

IEEE Transactions on Power Systems

**Publisher Rights Statement:**

(c) 2012 IEEE. Personal use of this material is permitted. Permission from IEEE must be obtained for all other users, including reprinting/ republishing this material for advertising or promotional purposes, creating new collective works for resale or redistribution to servers or lists, or reuse of any copyrighted components of this work in other works.

**General rights**

Copyright for the publications made accessible via the Edinburgh Research Explorer is retained by the author(s) and / or other copyright owners and it is a condition of accessing these publications that users recognise and abide by the legal requirements associated with these rights.

**Take down policy**

The University of Edinburgh has made every reasonable effort to ensure that Edinburgh Research Explorer content complies with UK legislation. If you believe that the public display of this file breaches copyright please contact [openaccess@ed.ac.uk](mailto:openaccess@ed.ac.uk) providing details, and we will remove access to the work immediately and investigate your claim.



# Smart Decentralized Control of DG for Voltage and Thermal Constraint Management

Thipnatee Sansawatt, *Graduate Student Member, IEEE*, Luis F. Ochoa, *Member, IEEE*, and

Gareth P. Harrison, *Member, IEEE*

**Abstract**—Active Network Management schemes are being developed to accommodate larger volumes of renewable generation within distribution networks. Approaches typically manage only single technical constraints or are highly complex with extensive sensing and communications needs that bring cost, deployment and operational risks. This work offers an alternative, decentralized approach for real-time management of local voltage and thermal constraints that avoids extensive sensing and communications. It controls generator active and reactive power output to overcome voltage and thermal issues near the point of connection. Results from time-series analyses reveal its effectiveness in managing both constraints and allowing greater production. It represents a potentially effective and fast-to-deploy alternative to more complex, integrated solutions.

**Index Terms**—Voltage constraints, thermal constraints, congestion management, active distribution networks, distributed generation, decentralized control, generation curtailment.

## I. INTRODUCTION

ACTIVE NETWORK MANAGEMENT (ANM) schemes are being developed and trialed to allow greater connection of distributed generation (DG) like wind power. These advanced control schemes aim to manage constraints to maximize use of the existing assets, release extra headroom and avoid reinforcement [1]. ANM is seen as a transitional step towards ‘smart’ distribution networks. With voltage and branch thermal constraints the most common limitation on DG capacity in (rural) distribution networks, ANM schemes focus on their management. A wide spectrum of ANM approaches range from fully ‘centralized’ methods requiring extensive sensing, communications and control infrastructure through to more ‘decentralized’ approaches that rely on local information and little or no communication. The following discussion captures the essence of the ANM spectrum but is not intended as a comprehensive review.

Fully *centralized* approaches depend heavily on real-time measurement and communication tools although the physical and electrical scope and sophistication differs. Currie et al. [2] created a real-time logic-driven method that curtails active

power generation to avoid line overloads at multiple network interfaces. It enacts curtailment in a strict ‘last-in-first-off’ merit order based on the sequence in which DG units were physically connected to the network. The approach has been successfully implemented in the thermally-constrained Orkney Isles network in Scotland [1]. Using a centralized controller and communication links the scheme measures line flows and generator output and delivers set point instructions to DGs.

White *et al.* [3] developed ‘GenAVC’ to control substation on-load tap changing (OLTC) transformer voltages to ensure multiple feeder voltages remain within limits. It estimates voltage along the feeders using information from remote measurement units fed back to a substation controller. It has been trialed at different UK sites but not yet been rolled out commercially. The voltage controller developed by Viehweider *et al.* [4] provides OLTC tap and DG active and reactive power settings using interval arithmetic and state machine methods to define the order of intervention. Xu *et al.* [5] use a case-based reasoning technique to deliver real-time voltage control by matching specific voltage problems with available control solutions; it is intended that multiple ‘zones’ collaborate through agent-based systems. Liew and Strbac [6] present several voltage constraint management strategies for worst-case conditions (maximum generation and minimum demand): reactive compensation, generation curtailment and area-based OLTC coordinated voltage control. Zhou and Bialek [7] outline a generation curtailment approach for multiple DG units to manage voltage constraints. It uses voltage-sensitivity factors to optimize the amount of power curtailed from each DG by equating higher sensitivity factors with more effective curtailment. The study’s snapshot solution misses the more complex voltage situations arising from variable DG. A more sophisticated method by Boehme *et al.* [8] uses sequential time-series optimal power flow to curtail variable wind, wave and tidal generators subject to voltage and thermal constraints. Implementing the approaches outlined above would require communications, measurement and a centralized controller.

A series of *decentralized* approaches have also been proposed. Kiprakis and Wallace [9] outline two voltage control schemes that employ local real-time synchronous generator terminal voltage measurements to specify the reactive power output from the DG. The first was a hybrid system that operates the DG in power factor control mode when voltages are within normal limits and switches to voltage control when voltages would otherwise exceed them. The second uses fuzzy logic to create a smooth function to define the target reactive power setting at a given voltage

---

This work is funded by the UK EPSRC Supergen FlexNet Consortium under the ‘Smart, Flexible Controls’ work-stream – full details on <http://www.supergen-networks.org.uk/>.

T. Sansawatt and G.P. Harrison are with the Institute for Energy Systems, School of Engineering, University of Edinburgh, Edinburgh, EH9 3JL, U.K. (e-mail: t.sansawatt@ed.ac.uk, gareth.harrison@ed.ac.uk).

L.F. Ochoa is with the School of Electrical and Electronic Engineering, The University of Manchester, Manchester, M13 9PL, U.K. (e-mail: luis\_ochoa@ieee.org).

level. The work also suggests ‘line rise’ compensation using a circuit emulator to allow use in long lines. The approach was found to facilitate almost as many new DG connections as a ‘perfect’ centralized management approach under worst case conditions [10]. Tran-Quoc *et al.* [11] developed a real-time auto-adaptive voltage regulator utilizing a voltage deadband system and fuzzy logic to determine the amount of active or reactive power required for voltage control from each DG unit connected to the same substation. Fila *et al.* [12] described a decentralized voltage control scheme that modifies the substation transformer voltage target to maintain feeder voltages within limits. Sited at the substation, the scheme uses no remote telemetry, instead relying on substation measurements, a network emulation model and historical SCADA data to estimate remote DG output and load conditions. A challenge is that it may not be able to immediately discern the instantaneous voltage rise associated with wind power injections.

Sansawatt *et al.* [13] developed an alternative power factor/voltage management scheme to locally mitigate voltage rise so more DG capacity can be connected. It also relies only on DG terminal voltage measurements but operates on a discrete time step. To facilitate larger DG capacities it also has a generator curtailment scheme that operates when the reactive power control alone cannot constrain voltages; this instigates a sequence of predefined reductions in active power output to lower voltages across each time step. The scheme also addresses interaction issue with OLTCs by adopting a time step shorter than the transformer delay time. The approach was further developed in [14] to manage thermal overloads.

The work presented here proposes real-time decentralized management of both voltage and thermal constraints. It is a substantial extension of the decentralized approach outlined in [13] and [14], and while these provide a basic framework, a new real-time voltage and flow sensitivity method is proposed as the core control. The ability to handle both constraint types and the avoidance of errors associated with fixed sensitivity factors, differentiates it from the literature. The control is performed at the DG unit itself (like [9] and [11]), and does not require remote telemetry or communication between DG units or with a central controller, thus reducing the economic and/or technical overhead. The approach is demonstrated on a time-series basis with variable generation and demand. While not without limitations it represents a valid and distinctive contribution to the transition towards smarter distribution networks.

This paper is set out as follows: section II explains the sensitivity-based decentralized control and section III demonstrates it on a simple test feeder. Section IV extends the scope to a more realistic distribution network incorporating multiple wind farms. A discussion is presented in section V, and conclusions are drawn in section VI.

## II. DECENTRALIZED CONSTRAINT MANAGEMENT

Distribution Network Operators (DNOs) require DG to have the capability to operate within specific power factor ranges. In the UK, this is a range of 0.95 inductive/capacitive which modern wind turbines can comply with. Despite the

capability, DNOs generally specify DG operation at fixed power factor around unity. This is due to reluctance to rely on third-party voltage regulation, as well as a lack of clear incentives and regulation for DG provision of reactive services [15, 16]. It also serves to maximize exports. However, there is a clear business case for generator-based control of active and reactive power to deliver additional DG capacity. This section details a decentralized scheme for DG control of its active and reactive power output to manage voltage and thermal constraints. Although the proposed scheme applies to any type of generation, wind power will be used for the case study.

The control scheme operates on a discrete time basis with conditions in one period used to define control actions in the next. It manages both voltage and thermal constraints by way of a series of *threshold* and *target* values which dictate whether the control actions are required at any given time step. Threshold values are defined at a level within the voltage or power flow limits. When measured values exceed these, corrective action is taken to reduce values to a target value at a more conservative level below the threshold. The deadband created by these two values avoids unnecessary activation of the control mechanisms. The correction uses real-time *sensitivity analyses* to define new active or reactive power set points. Where corrective action has been taken, operation will continue to be monitored against the thresholds to determine whether normal wind farm operation can be allowed without violating constraints. Both the threshold and the target values are particularly useful in the context of variable generation where fluctuations over a short period of time are frequent. The time step, threshold and target values can be set in such a way to promote more or less conservative operation.

### A. Voltage Constraint Management

In rural distribution networks, line resistance and reactance have similar magnitude. This means that reactive power control alone may be insufficient to mitigate voltage rise, forcing active power curtailment [13]. Revenue is maximized by prioritizing reactive power control at lower opportunity cost while using generation curtailment as a last resort. The two-stage voltage control mechanism is explained as follows.

Fig. 1 shows the control approach for voltage constraint management (termed ‘V Mgt’). Voltage at the wind farm connection point is monitored against a threshold,  $V_{threshold}$ . In normal operation with voltages within limits the wind farm operates at normal (unity) power factor. If voltage exceeds the threshold, the wind farm power factor becomes more inductive to lower the voltage to a target level,  $V_{target}$ . A power factor set point is calculated from the real-time voltage/reactive power ( $\delta V/\delta Q$ ) sensitivity to define the reactive power required to reduce voltage to the target level. Where the reactive power needed exceeds the wind farm’s capability, its active power output is curtailed. A new active power output set point is obtained by a voltage/active power ( $\delta V/\delta P$ ) sensitivity calculation to define the active power to be trimmed. The calculation accounts for the wind power available at the current wind speed  $P_{avail}$  (as defined by the wind anemometry and power curve) as well as the wind farm’s ramp rate limits.

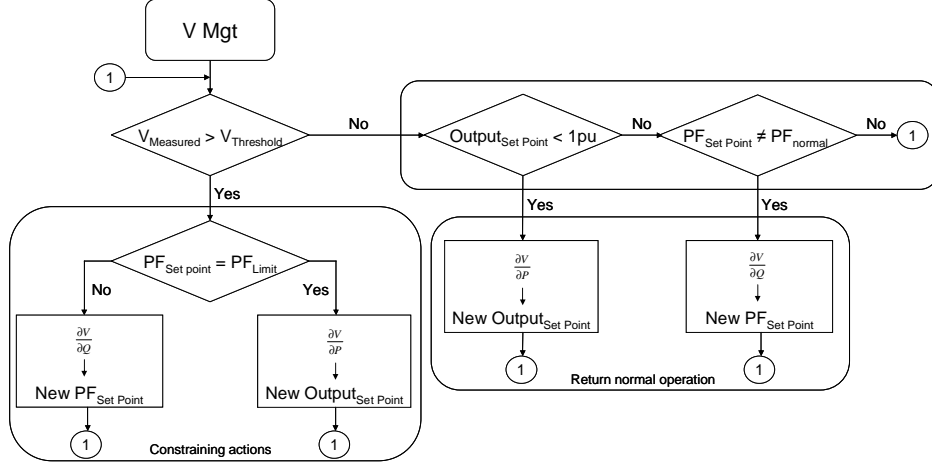

Fig. 1. Voltage constraint management (V Mgt) – High level control scheme.

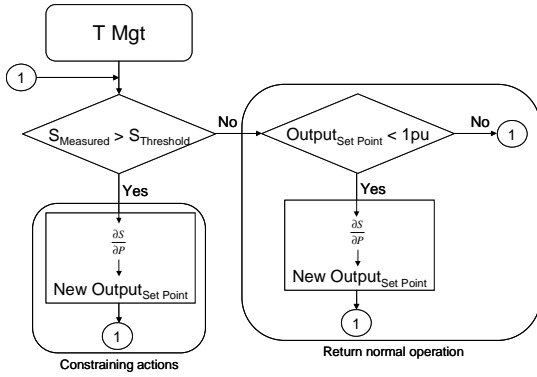

Fig. 2. Thermal constraint management (T Mgt).

When voltage falls below the threshold value, and the wind farm has already been constrained (i.e., power output and power factor set points are different from nominal/normal operation), then it is possible for it to return to initial settings (progressively if necessary) and make the most of the available wind. The decision to adjust the active or reactive set points depends on whether the turbines active power outputs are either (i) unconstrained, or (ii) constrained below the available wind power,  $P_{avail}$ . In case (i), reactive power import is reduced and a new, less inductive, set point is calculated. In case (ii), a new, higher, active power set point is defined. In all cases the relevant sensitivity is calculated in accordance with turbine ramp rate limits and the available production capability. This moves the wind farm towards normal unconstrained operation.

While intended to manage voltage rise, the algorithm could be modified to facilitate voltage support during low voltage episodes to comply with statutory low voltage limits or to reduce losses. With wind turbines this would be restricted to the export of reactive power as wind production cannot be raised beyond the available wind power,  $P_{avail}$ .

### B. Thermal Constraint Management

Generation curtailment is also employed to manage line thermal constraints (termed ‘T Mgt’) and control is also based on sensitivity analysis (Fig. 2). The constrained line through which wind power is directly exported towards the substation

is monitored against a line flow threshold,  $S_{threshold}$ . If the threshold is exceeded, the wind farm’s active power is trimmed to a new set point that lowers line loading to a target value,  $S_{target}$ . The reduction is estimated using the sensitivity of the line flow to the wind farm’s active power injection ( $\delta S/\delta P$ ) again subject to ramp rate limits and the available wind power. During the estimation process the DG reactive set point is constant such that  $\delta S/\delta P$  gives a sound estimate of the necessary curtailment. This is discussed further in section II.D.

When line loading falls below the threshold, a higher active power set point is defined by the sensitivity ( $\delta S/\delta P$ ). This moves the wind farm towards normal unconstrained operation, again within the limits of available wind power.

### C. Sensitivities

Corrective action sees the scheme calculate the required change in active or reactive power output by way of a sensitivity analysis. In each period the local state of the network is used to obtain the deviation of either voltage ( $\delta V$ ) or line flow ( $\delta S$ ) to unit changes in generator active or reactive power output:  $\delta V/\delta Q$ ,  $\delta V/\delta P$  or  $\delta S/\delta P$ . The sensitivity values are calculated for every time step as the voltage and line flows change with variations in demand and generation.

For voltage management, the reactive power ( $\Delta Q$ ) absorbed to alleviate voltage rise is computed from the target and measured voltages and the sensitivity value:

$$\Delta Q = \frac{V_{measured} - V_{target}}{\delta V / \delta Q} \quad (1)$$

and the active power to be curtailed ( $\Delta P$ ) is:

$$\Delta P = \frac{V_{measured} - V_{target}}{\delta V / \delta P} \quad (2)$$

For thermal management the active power to be curtailed to meet the target power flow in the next time step is:

$$\Delta P = \frac{S_{measured} - S_{target}}{\delta S / \delta P} \quad (3)$$

In all cases the wind farm’s active and reactive power limits apply. As the voltage or thermal control progressively returns to normal operation,  $\Delta P$  and  $\Delta Q$  values will become negative as the set points are revised upwards.

Once adjustments are made for the current period  $t$ , active and reactive power set points for the next period  $t+1$  are

obtained. In the absence of wind and demand forecasts at the site, the calculation assumes that the wind output  $W \in [0,1]$  and demand in  $t+1$  will be the same as in  $t$  (i.e. persistence forecasting,  $W_t = W_{t+1}$ ). This means the targets are unlikely to be precisely achieved. However, with short-time steps, the scope for substantial changes in conditions is reduced.

The active power output set point at  $t+1$ ,  $SP_{t+1}$ , defines the wind farm's maximum allowed production:

$$SP_{t+1} = \frac{P_t - \Delta P}{W_t \times P_{nom}} \quad (4)$$

where  $P_t$  is the active power output and  $P_{nom}$  the nominal wind farm capacity. The power factor set point  $PF_{t+1}$  is given by:

$$PF_{t+1} = \frac{P_t}{\sqrt{P_t^2 + (Q_t - \Delta Q)^2}} \quad (5)$$

where  $Q_t$  is the reactive power output at  $t$ .

The calculation of the sensitivities requires knowledge of the network parameters in the vicinity of the wind farm. In the simulation this is achieved by conducting a separate power flow for conditions in each period. For real implementation, wide-area monitoring is excluded from this local approach, alternatives are required. Options including a circuit emulator for line rise compensation [9] are discussed in section V.

#### D. Coordination of the Schemes

For active management of multiple simultaneously occurring constraints it is vital to coordinate each control schemes such that control actions are not unnecessarily replicated. Defining a priority control can provide appropriate sequences of actions to manage constraints effectively. The control priority also 'locks in' the use of one scheme at a time to avoid issues such as hunting that may arise from simultaneous functioning. In 'normal' conditions the wind farm operates at fixed power factor with production limited by the wind resource. Where both constraints occur together, priority is given to thermal constraint management. This is key to the scheme's operation as reactive power imports for voltage management will increase complex power flow and could worsen the line overload. While generation curtailment for thermal constraint management will also tend to limit voltage rise it may not be adequate in severe situations. Therefore once the line overload is handled, voltage management will activate for further action as necessary.

Modifying DG active and reactive power will both affect line apparent power flow. The priority given to thermal constraint management means that DG reactive power flows are assumed unchanged. This means that use of active power changes alone avoids large inaccuracies but errors from persistence forecasts of demand will be present.

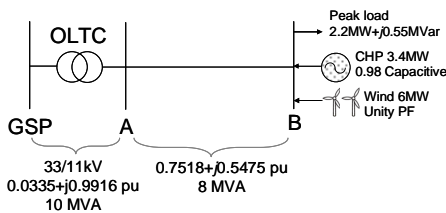

Fig. 3. Single line diagram of the 33/11-kV 3-bus test feeder (100 MVA base).

### III. SIMPLE CASE STUDY

The decentralized constraint management scheme is initially demonstrated on a small test feeder accommodating a wind farm. The analysis was carried out with the PSS/E power flow package automated through the Python programming language. It operates at a one-minute time step over an hour.

#### A. 3-Bus Test Feeder

Fig. 3 shows a 33/11-kV 3-bus test feeder. Peak demand at bus B is 2.2-MW but here a constant minimum demand level of 40% of peak is assumed throughout. Voltages at 33kV and 11kV are required by statute [17] to be within  $\pm 6\%$  of nominal. A combined heat and power (CHP) unit and a wind farm are also accommodated at the end of the feeder. The CHP unit operates at a constant 3.4-MW and 0.98 capacitive power factor. The 6-MW wind farm operates at unity power factor but has reactive power factor capabilities of 0.95 inductive/capacitive. Fig. 4 shows an hour-long minute-by-minute wind generation profile for a site in England (February weekday, 6-7am). This period is appropriate for testing the scheme as it represents a worst case scenario where high wind speeds coincide with minimum demand.

A simple rule to estimate the available capacity in a feeder (without N-1 constraints) is to consider the binding parameter during maximum generation and minimum demand: here this is the 8-MVA thermal capacity of line A-B. Assuming full CHP output and minimum demand (40%), the available fit-and-forget capacity for wind generation is 5.4-MW ( $8 - 3.4 + 0.88$ ). DG units beyond this capacity will overload the feeder and may cause voltage rise above 1.06pu. The control mechanisms permit larger connections such as the 6-MW wind farm in this case. A similar approach could be adopted with the CHP unit given the capability of synchronous generators. This has not been adopted here as the CHP may have heat-schedule constraints and there is a greater challenge in responding to the infrequent and severe overload cases arising from wind.

To examine the impact of voltage and thermal management, the case without control is compared with three others: voltage control alone; thermal management alone; and both schemes jointly. The voltage threshold and target are respectively set at 0.15 and 0.25 percentage points below the upper voltage limit (1.0585 and 1.0575pu). The line flow threshold and target are set to 4.5% and 5% below capacity, respectively. The wind farm ramp rate is assumed as 1-MW per minute. Experiments with different threshold and target settings were carried out for the test period. The conservative values adopted avoided excessive overloads for the specific wind variability, network impedances, voltage and power flow sensitivity and the action of the OLTC. However, the settings are intended to be tailored to other networks to deliver more or less conservative constraints on voltage and power flows.

#### B. Voltage Management

Fig. 5 (top) shows the voltage profile at bus B with and without the voltage management scheme (V Mgt). When voltage exceeds the threshold, the scheme is activated. For

instance, voltage at minute 1 (1.061 pu) exceeds the threshold. The first action is to calculate the voltage sensitivity at that instant. A snapshot power flow of the network state at minute 1 is used to calculate the voltage drop resulting from the absorption of 1-Mvar by the wind farm. The voltage sensitivity, 0.0148 pu/Mvar in this case, is then used with (1) to estimate the change in reactive power necessary to reduce the voltage to the target. Thus, the required (inductive) reactive power for minute 2 can be estimated as follows:

$$\Delta Q = \frac{1.061 \text{ pu} - 1.0575 \text{ pu}}{0.0148 \text{ pu/Mvar}} = 0.24 \text{ Mvar}$$

This value is negative in Fig. 5 as reactive power is absorbed.

Where the voltage is below the threshold value, the wind farm continues to operate at the adjusted power factor until the wind speed increases or decreases (demand is constant). In the former case voltage may rise above the threshold prompting a new, more inductive, set point, as shown for minutes 21 to 33 in Fig. 5 (bottom). If wind drops, the farm adjusts to unity power factor operation (e.g. minutes 13 to 17). In this way, the voltage is maintained around the target value for extended periods. For this test period, the reactive power capability was sufficient and generation curtailment was not required for voltage management. The analysis accounts for the reduction in reactive capability as the wind output drops.

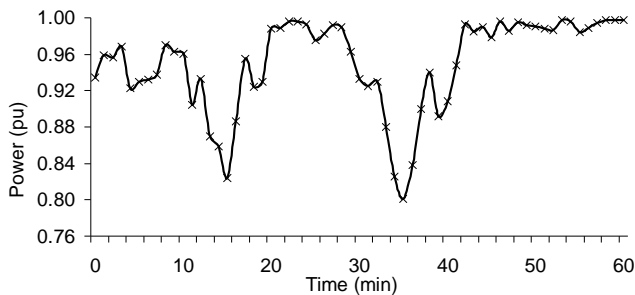

Fig. 4. 60-minute wind generation profile (pu of nominal capacity).

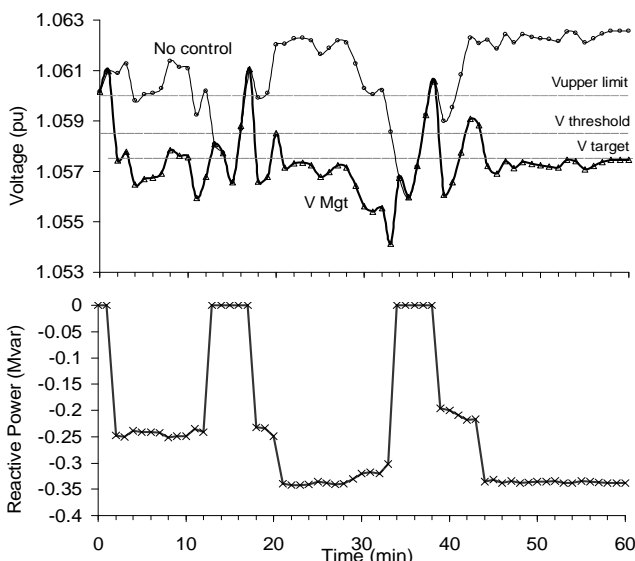

Fig. 5. (top) Voltage profile at bus B applying the voltage management scheme (V Mgt) and (bottom) reactive power absorbed by the wind farm.

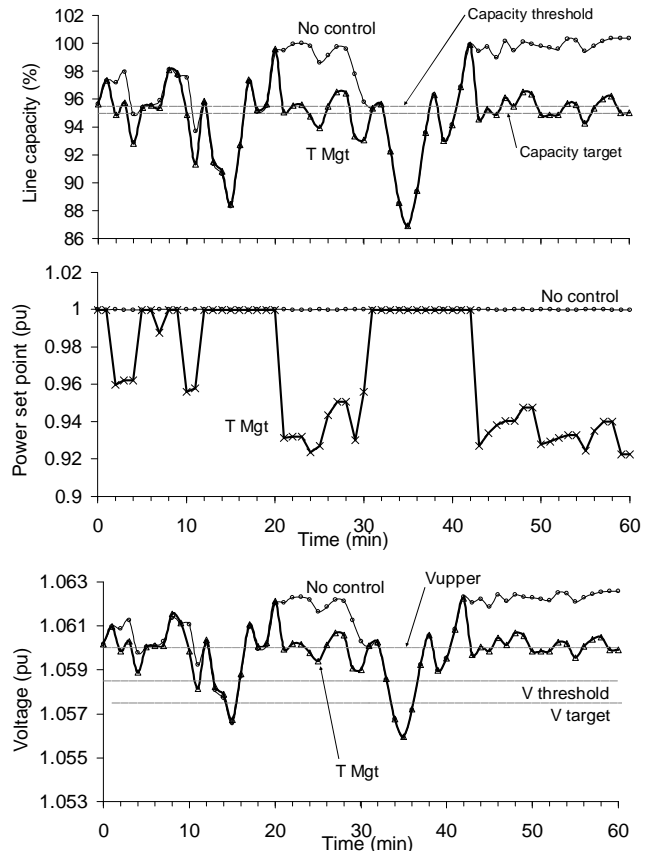

Fig. 6. (top) Capacity usage of line A-B with the thermal management scheme (T Mgt); (middle) wind farm power set point (pu of nominal capacity); and (bottom) Voltage profile at bus B under the thermal management.

### C. Thermal Constraint Management

Fig. 6 (top) shows the pattern of line usage with and without the thermal constraint management scheme (T Mgt). Similarly to voltage (Fig. 5) line loading varies with wind power injection. When the power flow exceeds the capacity threshold, the control scheme is activated and actions the wind farm to trim its power output to a new generation level (Fig. 6 (middle)) to maintain the loading at the capacity target. The effect of the generation curtailment in the thermal management scheme on the voltage profile at bus B is shown in Fig. 6 (bottom). The pattern is similar to the line capacity as a result of the active power control.

The sensitivity calculation is performed in a similar way to the V Mgt. At minute 1, the line loading (97.3%) exceeds the threshold. A snapshot analysis indicates that curtailing 1-MW from the wind farm lowers line loading by 11.3%. Using (3), the loading sensitivity is used to calculate the real power to be trimmed to meet the target loading (95%):

$$\Delta P_{t=1} = \frac{97.33\% - 95\%}{11.3\% / \text{MW}} = 0.21 \text{ MW}$$

In minute 1, a power output of 5.75-MW means the trimming instruction would lower the power output to 5.54-MW ( $W_{t=1}$  is 0.96pu). This resulting power set point for minute 2 is:

$$SP_{t=2} = \frac{5.54 \text{ MW}}{0.96 \text{ pu} \times 6 \text{ MW}} = 0.96$$

With actual wind production in minute 2,  $W_{t=2}$ , slightly lower

than forecast (0.956pu), line loading undershoots the target to 94.85%. The scheme will respond by calculating a higher set point for minute 3 to take advantage of the extra headroom. With an updated sensitivity of 11.25%/MW and instantaneous power output of 5.508-MW,  $SP_{t=3}$  is:

$$\Delta P_{t=2} = \frac{94.85\% - 95\%}{11.25\% / \text{MW}} = -0.013 \text{ MW}$$

$$SP_{t=3} = \frac{5.508 \text{ MW} - (-0.013 \text{ MW})}{0.956 \text{ pu} \times 6 \text{ MW}} = 0.962$$

With this set point the actual line capacity in minute 3 was observed at slightly above the threshold due to a small wind increase. The process then repeats to produce a new set point for minute 4. At this point, wind production dropped enough for line flow to fall below the threshold, prompting a higher set point to be estimated, which in this case, was a return to 'normal' unconstrained operation in minutes 5 to 6 ( $SP_{t=5} = 1$ ).

#### D. Joint Voltage and Thermal Constraint Management

Fig. 7 and Fig. 8 show the voltage profiles, power output, line loading and active and reactive set points as a result of the joint voltage and thermal constraint management (V&T Mgt). In this case voltage rise and high line loading occur together with priority given to thermal constraint management. It can be seen that when the thermal management scheme is activated (e.g., minutes 1 to 4) the voltage profile follows a similar pattern to line loading. In minute 5 the line flow is maintained below its threshold, but voltage remains above its own threshold. Voltage management is activated resulting in an inductive power factor set point that lowers the voltage. The wind farm operates with these set points until minute 8 when the wind speed increases force the thermal management scheme to issue a new active power set point. In the next period the wind speed drops causing line flow to fall 4 percentage points below the target. With this extra headroom, the scheme reacts to increase the active power set point to unity. The power set point behavior is similar to that in Fig. 6 due to the thermal control priority. The generation curtailment with T Mgt is seen to assist in lowering voltages. Consequently, the reactive power required to manage voltage rise is less than for the V Mgt scheme alone (Fig. 8 (bottom)).

#### E. Interaction with the OLTC

As presented, the constraint management schemes operate on a minute-by-minute time scale and are assumed to be faster than (and independent from) the OLTC cycle (that could be more than a minute). For this purpose, the OLTC operates *after* the management scheme in the next period (in this case, a minute). A power flow, considering the OLTC, the new set points, and the new demand and generation levels, is then run to determine the network state and perform corrective action as needed. This avoids any hunting effect between the OLTC and the scheme. A similar procedure applies to the full case study in section IV that operates on a 10-minute time step. Coordination of DGs and the OLTC is discussed in section V.

## IV. FULL CASE STUDY

The full scheme is now extended to a more realistic network to

assess the effectiveness for voltage and thermal constraints that occur with variations in both load and generation. The controls are applied to two wind farms in order to examine the behavior with multiple DG plants. The performance is assessed on the basis of its ability to manage both constraints simultaneously and in terms of the exported energy.

#### A. Network, Load and Generation

Fig. 9 shows a modified 12-bus rural distribution network obtained from the UK Generic Distribution System [18]. To increase voltage and power flow sensitivity several buses and the voltage regulator between buses 8 and 9 are omitted. The peak demand is 36.6-MW. As before, the CHP unit at bus 12 is not actively controlled and operates at constant 3.5-MW and

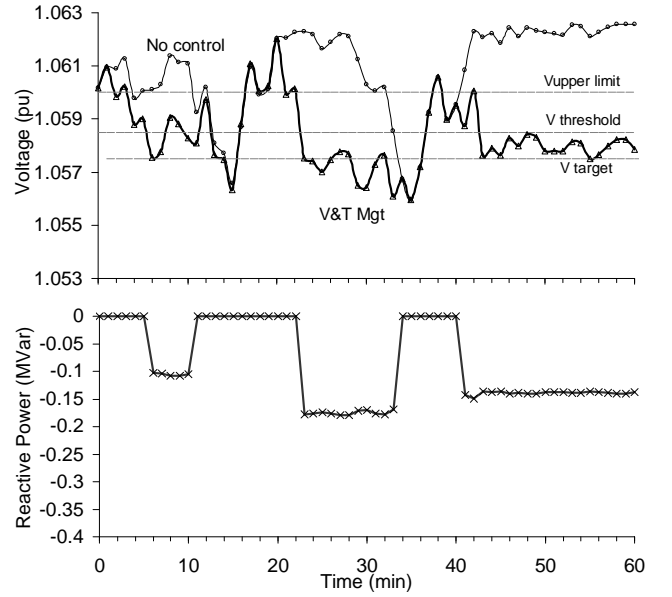

Fig. 7. (top) Voltage profiles at bus A and (bottom) wind farm's reactive power using the voltage and thermal constraint management (V&T Mgt).

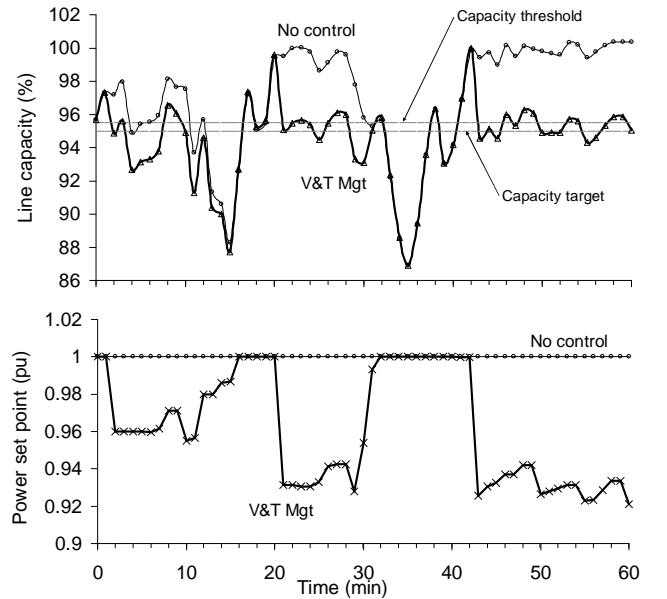

Fig. 8. (top) Capacity usage of line A-B and (bottom) wind farm's power set point using the voltage and thermal constraint management (V&T Mgt).



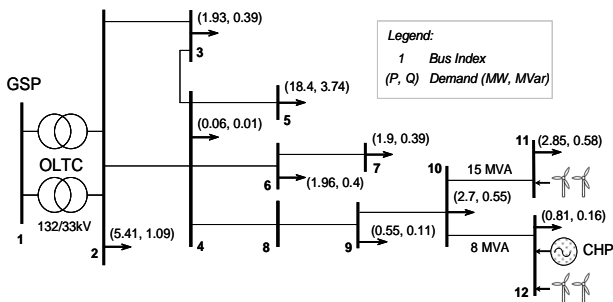

Fig. 9. Modified 12-bus 33kV rural distribution network (UK GDS [18]).

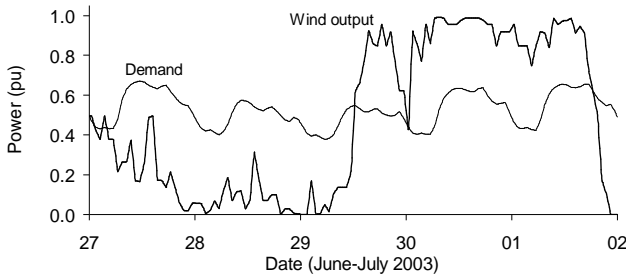

Fig. 10. 5-day plot for wind power output (pu of nominal capacity).

0.97 inductive power factor. The two wind sites at buses 11 and 12 are geographically close but distant enough to have different wind profiles. Demand and wind speed data for central Scotland in 2003 was used and wind production was estimated using a generic wind power curve [19]. It is assumed that the wind resource at bus 12 is better than at bus 11 with capacity factors of 0.45 and 0.41, respectively.

### B. Smart Decentralized Control

With the fit-and-forget operation the network can host around 3-MW of capacity at each wind site. Raising the capacity at each site will tend to create over-voltages at the connection buses (11, 12) and overload lines 10-11 and 10-12. To demonstrate that the decentralized constraint management scheme can increase the connection of new generation capacity without compromising network operation, 6-MW of wind capacity is accommodated at each site and operates at unity power factor. To illustrate a full range of wind generation and demand combinations a one year window at a 10-minute time step is analyzed. Actual implementation would be at much smaller time steps.

To show how the control mechanisms interact, a 5-day sample window depicting summer minimum demand is illustrated. Wind production and demand during the period is shown in Fig. 10. Time-series results for voltage at bus 12 and the loading of line 10-12 are shown in Fig. 11 and Fig. 12, respectively. The better wind resource and lower demand at bus 12 and the lower capacity of line 10-12, makes control action impacts more significant than at bus 11. As such, samples for bus 11 are omitted.

Over the first two days the wind speeds are relatively low and voltage and line flows stay within their thresholds. High wind speeds in the second half of the period (29<sup>th</sup> June onwards) results in simultaneous voltage rise and line loading impacts, requiring actions from the generation curtailment and

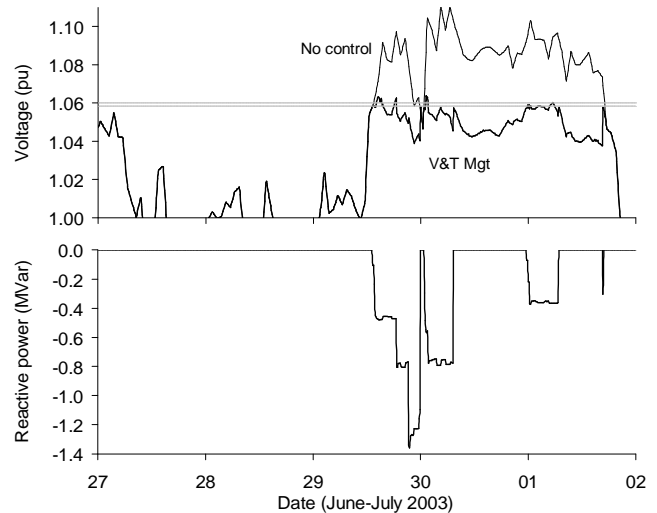

Fig. 11. (top) 5-day plots of voltage profile and (bottom) reactive power output at bus 12 for no control and V&T Mgt.

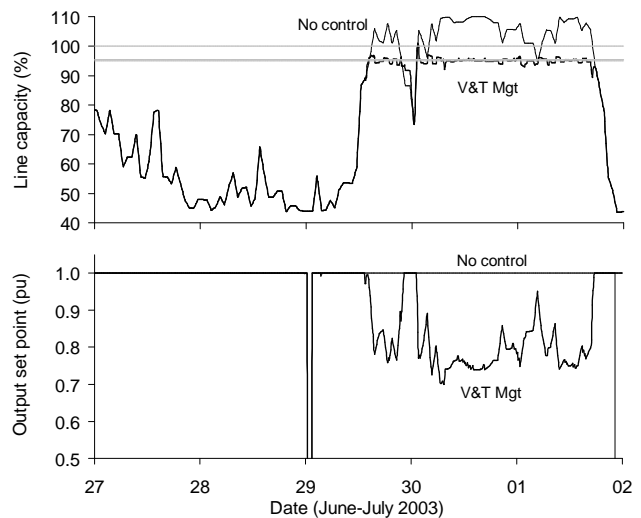

Fig. 12. (Top) 5-day plots for line powers for line 10-12 and (bottom) set point of the wind farm for no control and V&T Mgt.

the reactive power controls. Note that the drop in power output to zero on 29<sup>th</sup> June is due to the momentary absence of wind (Fig. 9). The main control action over the severe period was thermal management and line flow was maintained around the target value to ensure the high wind power could be securely delivered. The voltage at bus 12 over the severe period was also effectively managed within the voltage limits. The (inductive) reactive power used for V Mgt was not required as extensively given the relief brought by the generation curtailment.

Table I summarizes the performance over the year. Fig. 11 and Fig. 12 show that with fit-and-forget operation 6-MW farms at buses 11 and 12 would cause severe voltage rise and overloads. However, the voltage and thermal management scheme effectively handled both constraints allowing secure connection of 6-MW of new wind capacity. Although some voltage rise at bus 12 and overloading of the line 10-12 remains, the duration and magnitudes were very small. The



capacity of line 10-11 was sufficient to accommodate the 6-MW wind farm; therefore, the thermal overload impact at that location was not an issue.

Table I also shows that, compared to the fit-and-forget approach, the control scheme raises the wind energy yield by almost 100% and 72% at the wind farms at buses 11 and 12, respectively. The capacity factors, which offer a proxy for the economics of wind developments, are impacted differently: marginally at bus 11, but with a reduction of 15% at bus 12. Voltage and thermal constraints at the latter are more significant, driving more curtailment and smaller capacity factor. The financial aspects will ultimately dictate whether a development using the proposed active management approach is feasible or not.

TABLE I  
FULL YEAR ASSESSMENT: PERIODS OF VOLTAGE RISE AND LINE OVERLOAD,  
EXPORTED ENERGY AND WIND CAPACITY FACTOR.

Cases	No control 2 × 3-MW	V&T Mgt 2 × 6-MW
Overvoltage Bus 11	None	None
Overvoltage Bus 12	0.21%	2.4%
Overload Line 10-11	None	None
Overload Line 10-12	None	0.1%
Energy export Bus 11	10.8GWh/year	21.71 GWh/year
Energy export Bus 12	12.6GWh/year	21.69 GWh/year
Capacity factor Bus 11	0.41	0.41
Capacity factor Bus 12	0.45	0.41

## V. DISCUSSION

The voltage and thermal management scheme is decentralized and measurements are limited to the point of connection of the DG plant to avoid costs associated with communication and measurement systems. Consequently, real-time observation of other network parameters is not possible. However, the sensitivity analysis requires knowledge of a small number of local network parameters. These can be estimated, for instance, by adopting an equivalent circuit of the network or having a localized state estimator. The latter would involve a real-time computer analysis of the network using only the available local measurements.

The sensitivity methods require frequent calculations and there will inevitably be errors present. In part, this will arise from the persistence forecast model for wind production and demand (see section III.C) but also due to the linearization necessary in the sensitivity approach. These may be more apparent during large changes but short time steps will tend to limit these. Further, linearization about the instantaneous operating point will result in smaller errors than fixed sensitivity factor methods. Alternatives to the sensitivity method include simple fixed increase and decrease factors; these will reduce the calculation time but likely will result in greater error and less optimal operation.

The scheme can be scalable and adaptable to different network topologies, load and generation patterns. The process of selecting the control parameters would be fairly straightforward given that there are only a small set of threshold and target values. It would need to be seen to operate across a wide range of credible circumstances and

with tolerable error. Less conservative settings would promote enhanced production but increase risk of overloads and over-voltages. The settings will be influenced by: the DNO's tolerance of transient over-voltages and overloads; the expected rate of change of wind and demand between time-steps; whether short-term forecasts are applied; and the speed of OLTC operation. It is expected that an automated routine could be developed to 'optimize' the parameters perhaps on a multi-criteria basis.

The control interactions between multiple DG plants and voltage regulation devices need to be defined on a case-by-case basis. Actual implementation of the scheme would be on a faster time step than in the case studies and substantially faster than the control loop of an OLTC. This can minimize unnecessary OLTC tapping action as it will sense voltage as corrected by the scheme. Where the voltage cannot be managed locally by the DG, then the OLTC will do so. The broadly same approach could be applied to coordination between DG units through differentiation of their control parameters and the 'droop' characteristic provided by the sensitivity factors exploited. The DG at the most 'sensitive' site would operate at shorter time intervals than others so that most benefit will be derived from the most influential actions, with others following as required. While coordination needs additional work it is understood to be an adequate approach.

While the scheme is limited to DG able to control reactive power, this is not overly restrictive. Modern DFIG and PMG wind turbines are capable of fast active and/or reactive power adjustment following control instruction [20, 21]. These capabilities are shared with synchronous generators and inverter-interfaced technologies like PV. The incremental costs must obviously be considered.

It should be recognized that there are limitations arising from the preservation of 'local-only' measurement although relaxation of this would extend the range of applications. The voltage and line loading sensitivity methods allow fairly precise control actions in real time. However, the local measurement and control and avoidance of direct communication with nearby DG and OLTCs may make this approach less 'optimal' in terms of overall integration than 'centralized' approaches. With this in mind, a comprehensive comparison of risks and benefits of different schemes would be of value to DNOs, suppliers and DG developers in planning ANM for existing or new DG connections.

Further improvements of the management scheme and control capability would include: short-term forecasting; further work on specific algorithms to coordinate DG units and/or OLTC transformers; as well as a suite of 'operational windows' wherein control responds to situations with different levels of severity.

## VI. CONCLUSIONS

A decentralized control strategy is proposed to mitigate voltage rise and line overloads in (rural) distribution networks to facilitate increased connections of wind generation. It uses both reactive power control and generation curtailment in a real-time sensitivity method that tackles voltage and thermal

constraints local to the DG connection. The ability to handle both constraints and the avoidance of errors associated with fixed sensitivity factors differentiates it from existing approaches. Time-series simulations of wind generation demonstrate the effectiveness of the control method in providing real-time constraint management and the logical control mechanism is able to promptly clear the situations where both constraints coincide. The approach offers a comparatively simple, reduced-cost and fast-to-deploy alternative to communications-dominated centralized schemes and has potential as an interim step towards smart distribution networks. Further work is required on tuning of the parameters for specific network, demand and generation characteristics as well as ensuring coordination between DG plants and OLTCs. A comprehensive comparison of the risks and benefits of this and other ANM schemes is highlighted as being of value to DNOs, suppliers and DG developers.

## VII. REFERENCES

- [1] R. A. F. Currie, G.W. Ault, R.W. Fordyce, D.F. MacLeman, M. Smith and J.R. McDonald, "Actively managing wind farm power output," *IEEE Trans. Power Syst.*, vol. 23, pp. 1523-1524, 2008.
- [2] R. A. F. Currie, G.W. Ault, C.E.T. Foote and J.R. McDonald, "Active power-flow management utilising operating margins for the increased connection of distributed generation," *IET Gener. Transm. Distrib.*, vol. 1, 2007.
- [3] S. White, "Active local distribution network management for embedded generation - GEN AVC," prepared for DTI Technology Programme in contracted by Econect Ltd K/EL/00271/REP, 2005.
- [4] A. Viehweider, H. Schichl, D. Burnier de Castro, S. Henein and D. Schwabeneder, "Smart robust voltage control for distribution networks using interval arithmetic and state machine concepts," in *IEEE PES Innovative Smart Grid Technologies (ISGT) Europe, 2010*, Gothenburg, Sweden, 2010, pp. 1-8.
- [5] T. Xu, P. Taylor, M. Prodanovic, T. Green, E. Davidson and S. McArthur, "Case based reasoning for distributed voltage control," in *20th International Conference on Electricity Distribution, 2009. CIREN 2009*, Prague, 2009, pp. 1-4.
- [6] S. N. Liew and G. Strbac, "Maximising penetration of wind generation in existing distribution networks," *IEE Proc., Gen., Transm. & Distrib.*, vol. 149, pp. 256-262, 2002.
- [7] Q. Zhou and J. W. Bialek, "Generation curtailment to manage voltage constraints in distribution networks," *Generation, Transmission & Distribution, IET*, vol. 1, pp. 492-498, 2007.
- [8] T. Boehme, G.P. Harrison and A.R. Wallace, "Assessment of distribution network limits for non-firm connection of renewable generation," *IET Renew. Pwr. Gen.*, vol. 4, pp. 64-74, 2010.
- [9] A. E. Kiprakis and A. R. Wallace, "Maximising energy capture from distributed generators in weak networks," *IEE Proc., Gen., Transm. & Distrib.*, vol. 151, pp. 611-618, 2004.
- [10] P. N. Vovos, A.E. Kiprakis, A.R. Wallace and G.P. Harrison, "Centralized and Distributed Voltage Control: Impact on Distributed Generation Penetration," *IEEE Trans. Power Systems*, vol. 22, pp. 476-483, 2007.
- [11] T. Tran-Quoc, E. Monnot, G. Rami, A. Almeida, Ch. Kieny and N. Hadjsaid, "Intelligent voltage control in distribution network with distributed generation," in *19th Intl Conf. on Electricity Distribution, CIREN*, Vienna, 2007.
- [12] M. Fila, J. Hiscock, D. Reid, P. Lang and G.A. Taylor, "Flexible voltage control in distribution networks with distributed generation - modelling analysis and field trial comparison," in *20th International Conference on Electricity Distribution, CIREN*, Prague, 2009.
- [13] T. Sansawatt, L.F. Ochoa and G.P. Harrison, "Integrating distributed generation using decentralised voltage regulation," in *IEEE Power and Energy Society General Meeting (IEEE PES GM)*, Minneapolis, USA, 2010.
- [14] T. Sansawatt, L.F. Ochoa and G.P. Harrison, "Decentralised voltage and thermal management to enable more distributed generation connection," in *CIREN Workshop*, Lyon, 2010.
- [15] S. Cowdroy and G. Nicholson, "Reactive power charging for generators," Technical note prepared for Distributed Working Group (DWG), 2006.
- [16] BERR, "Active Network Management (ANM) Technology: Current Technology Issues and Identification of Technical Opportunities for Active Network Management," prepared by Sinclair Knight Merz for Department for Business Enterprise & Regulatory Reform, 2008.
- [17] *Statutory Instruments: The Electricity Safety, Quality and Continuity Regulations.*, The National Archives, HM Government. Available: <http://www.legislation.gov.uk/uksi/2002/2665/contents/made>, 2002.
- [18] *United Kingdom Generic Distribution System*. Available: <http://monaco.eee.strath.ac.uk/ukgds/>
- [19] T. Boehme, J. Taylor, A.R. Wallace and J. Bialek, "Matching Renewable Electricity Generation with Demand," Scottish Executive, Edinburgh, 2006.
- [20] T. Ackermann, *Wind power in power systems*. United Kingdom: John Wiley & Sons, Ltd., 2005.
- [21] J. L. Rodriguez-Amenedo, S. Arnalte and J.C. Burgos, "Automatic generation control of a wind farm with variable speed wind turbines," *Energy Conversion, IEEE Transactions on*, vol. 17, pp. 279-284, 2002.

## VIII. BIOGRAPHIES



**Thipnatee Sansawatt** (S'09) received the B.Eng. degree in 2006 from Sirindhorn International Institute of Technology, Thammasat University, Bangkok, Thailand. In 2007, she obtained the M.Sc. degree from the University of Edinburgh, U.K., where she is currently pursuing a Ph.D. Her research interests include renewable distributed generation and smart management of distribution networks.

Ms Sansawatt is a member of the Institution of Engineering and Technology, U.K.



**Luis F. Ochoa** (S'01-M'07) received the B.Eng. degree from UNI, Lima, Peru, in 2000 and the M.Sc. and Ph.D. degrees from UNESP, Ilha Solteira, Brazil, in 2003 and 2006, respectively.

He is a Lecturer at The University of Manchester, U.K. From 2007 to 2010, he was a Research Fellow at the University of Edinburgh, U.K. His current research interests include network integration of distributed energy resources and smart distribution networks.



**Gareth P. Harrison** (M'02) is Bert Whittington Chair of Electrical Power Engineering at the University of Edinburgh, U.K. His current research interests include network integration of renewable generation and analysis of the impact of climate change on the electricity industry.

Prof. Harrison is a Chartered Engineer and member of the IET.