



THE UNIVERSITY *of* EDINBURGH

Edinburgh Research Explorer

Confirmation of two quantitative trait loci regions for nematode resistance in commercial British terminal sire breeds

Citation for published version:

Matika, O, Pong-Wong, R, Woolliams, JA & Bishop, SC 2011, 'Confirmation of two quantitative trait loci regions for nematode resistance in commercial British terminal sire breeds', *Animal*, vol. 5, no. 8, pp. 1149-1156. <https://doi.org/10.1017/S175173111100022X>

Digital Object Identifier (DOI):

[10.1017/S175173111100022X](https://doi.org/10.1017/S175173111100022X)

Link:

[Link to publication record in Edinburgh Research Explorer](#)

Document Version:

Publisher's PDF, also known as Version of record

Published In:

Animal

Publisher Rights Statement:

Copyright The Animal Consortium 2011

General rights

Copyright for the publications made accessible via the Edinburgh Research Explorer is retained by the author(s) and / or other copyright owners and it is a condition of accessing these publications that users recognise and abide by the legal requirements associated with these rights.

Take down policy

The University of Edinburgh has made every reasonable effort to ensure that Edinburgh Research Explorer content complies with UK legislation. If you believe that the public display of this file breaches copyright please contact openaccess@ed.ac.uk providing details, and we will remove access to the work immediately and investigate your claim.



Confirmation of two quantitative trait loci regions for nematode resistance in commercial British terminal sire breeds

O. Matika[†], R. Pong-Wong, J. A. Woolliams and S. C. Bishop

The Roslin Institute and Royal (Dick) School of Veterinary Studies, The University of Edinburgh, Roslin, Midlothian EH25 9RG, UK

(Received 1 September 2010; Accepted 23 December 2010; First published online 22 February 2011)

Sheep internal parasites (nematodes) remain a major health challenge and are costly for pasture-based production systems. Most current breeding programmes for nematode resistance are based on indicator traits such as faecal egg counts (FEC), which are costly and laborious to collect. Hence, genetic markers for resistance would be advantageous. However, although some quantitative trait loci (QTL) have been identified, these QTL are often not consistent across breeds and few breeding strategies for nematode resistance in sheep are currently using molecular information. In this study, QTL for nematode resistance on ovine chromosomes (OAR) 3 and 14, previously identified in the Blackface breed, were explored using commercial Suffolk (n = 336) and Texel lambs (n = 879) sampled from terminal sire breeder flocks in the United Kingdom. FEC were used as the indicator trait for nematode resistance, and these were counted separately for Nematodirus and Strongyles genera. Microsatellite markers were used to map the QTL and the data were analysed using interval mapping regression techniques and variance component analysis. QTL for Nematodirus and Strongyles FEC were found to be segregating on OAR3 at 5% chromosome region-wide significance threshold in both Suffolk and Texel sheep, and Nematodirus FEC QTL were segregating on OAR14 in both breeds. In addition, QTL for growth traits were also found to be segregating at 5% chromosome region-wide on OAR3 and OAR14. The confirmation that FEC QTL segregate in the same position in three widely used breeds widens their potential applicability to purebred Blackface, Suffolk and Texel sheep, with benefits likely to be observed in their commercial crossbred progeny.

Keywords: nematode resistance, quantitative trait loci, lambs, Texel, Suffolk

Implications

The confirmation that QTL affecting nematode resistance are segregating in several breeds widens their potential applicability to British sheep industry. In the past, difficulties in collecting faecal egg count's phenotypes in the field have made it a challenge to routinely implement nematode resistance in selection programmes. Our results may assist with the implementation of marker-assisted selection when selecting for nematode resistance. This also paves the way for further study to identify single nucleotide polymorphisms (SNPs) in population wide linkage disequilibrium with the causative mutations, or SNPs, which themselves are the causative mutations.

Introduction

Gastrointestinal parasites remain a major health challenge for pasture-based sheep production systems, and the annual

costs of gastrointestinal parasite (nematode) infections to the British sheep industry have been estimated at ca. £84 million (Nieuwhof and Bishop, 2005). Breeding for nematode resistance in sheep has been proposed as a sustainable method for assisting in the control of nematode infections in grazing sheep, for example, Bishop and Stear (2001), particularly with increasing anthelmintic resistance problems. Most of the current breeding programmes for nematode resistance are based on indicator traits, especially faecal egg counts (FEC), which are costly and laborious to collect. Hence, genetic markers for resistance would be advantageous. Although some quantitative trait loci (QTL) have been identified, these QTL are often not consistent across breeds and few breeding strategies for nematode resistance in sheep are currently using molecular information.

Previous studies conducted at Roslin Institute (Davies *et al.*, 2006), using Blackface sheep, identified regions of particular interest in ovine chromosomes (OAR) 3, 14 and 20. The regions on OAR3 and OAR20 are two of the few QTL for nematode resistance that are common across several studies (Buitkamp *et al.*, 1999; Coltman *et al.*, 2001; Charon *et al.*, 2002;

[†] E-mail: oswald.matika@roslin.ed.ac.uk

Crawford *et al.*, 2006; Beraldi *et al.*, 2007). Furthermore, these regions contain plausible candidate genes, namely, interferon- γ (IFNG) and possibly genes located in the major histocompatibility complex, respectively. The region on OAR14 has only been observed in Blackface sheep (Davies *et al.*, 2006), although another OAR14 FEC QTL was reported in Spanish milk sheep (Gutierrez-Gil *et al.*, 2009). The region described by Davies *et al.* (2006) contains interferon regulatory factor (IRF3), a toll-like receptor (TLR)-related gene. As reported by Jann *et al.* (2009), IRF3 is located in QTL regions affecting health traits in five species (human, mouse, pig, cattle and sheep) and, as such, is a plausible candidate gene for our QTL on OAR14.

In this study, we wish to explore the two QTL of those described above that we consider more likely to contribute to nematode resistance breeding programmes, namely those on OAR3 and OAR14. The aim is to determine whether QTL in these regions are also segregating in the two most important terminal sire breeds in the United Kingdom, namely the Texel and Suffolk breeds. The rationale for this study is that consistency of QTL across breeds would markedly improve the prospects of ultimately using genetic markers for nematode resistance.

Material and methods

Animals sampled

Commercial Suffolk and Texel sheep with performance and pedigree records were sampled from 2005 and 2006 from terminal sire breeder flocks in the United Kingdom. Animals targeted for FEC sampling were part of a larger study exploring the use of markers in commercial sheep flocks (Matika *et al.*, 2010). Initially, 335 Suffolk records in 13 half-sib families and 927 Texel in 26 half-sib families were available after correcting

for Mendelian genotyping errors (Table 1). After further editing based on family size, the Suffolk and Texel data sets were reduced to 296 records from nine half-sib families and 879 records in 26 half-sib families, respectively. A summary of the data used is given in Table 1. DNA was extracted from a blood sample collected from each animal. In addition, all animals had measurements for live weight at 8 weeks, and muscle and fat depth measured ultrasonically over the 3rd lumbar and weight at scanning (ca. 20 weeks of age). These performance trait data were all normally distributed.

Parasitological phenotypes

Faecal samples were collected from the rectum of the lambs at approximately 20 weeks of age. Sheep breeders sent the samples directly to a commercial laboratory for FEC assays using well-established identification criteria based on egg size and morphology. On these samples, FEC were measured using the modified McMaster technique (Whitlock, 1948) with a lower detection limit of 50 eggs per gram (epg) of faeces for the 2005 samples, and the FECPAK assay method (<http://www.fecpak.com>; see McCoy *et al.*, 2005; Coles *et al.*, 2006) with a lower detection limit of 30 epg was used for the 2006 samples.

Parasite eggs were classified according to whether they were *Nematodirus* spp. or other nematodes collectively termed *Strongyles*. The *Strongyles* potentially include the following nematode genera: *Oesophagostomum*, *Chabertia*, *Bunostomum*, *Trichostrongylus*, *Cooperia*, *Ostertagia*, *Teladorsagia* and *Haemonchus*. The egg counts for *Nematodirus* spp. were recorded separately, as the biology of this parasite differs from other *Strongyles*.

The *Nematodirus* and *Strongyles* FEC data were right skewed and normalised using logarithmic transformation ($LFEC = \ln(FEC + x)$, where x is a constant used to avoid

Table 1 Summary statistics of FEC and scanning weight and their s.d. in the Suffolk and Texel sheep data

	Trait				Scanning weight \pm s.d.
	<i>Strongyles</i> \pm s.d.		<i>Nematodirus</i> \pm s.d.		
	Raw	LS ₁	Raw	LN ₁	
Breed					
Suffolk					
Number of records	296		231		266
Number of families (family size)	8 (16 to 106)		9 (6 to 89)		8 (16 to 106)
Number of zeros	109		153		
Maximum value	1900	7.55	500	6.22	
Mean of non-zero values	300 \pm 340	5.16 \pm 1.07	93.3 \pm 90.2	4.23 \pm 0.74	53.7 \pm 10.2
Texel					
Number of records	879		879		855
Number of families (family size)	26 (6 to 141)		26 (6 to 141)*		26 (6 to 141)
Number of zeros	247		674		
Maximum value	2610	7.87	1100	7.00	
Mean of non-zero values	245 \pm 329	4.94 \pm 1.02	110 \pm 134	4.31 \pm 0.81	44.6 \pm 8.67

FEC = faecal egg counts; LS₁ = $\ln(\text{Strongyles FEC} + 1)$; LN₁ = $\ln(\text{Nematodirus FEC} + 1)$.

*Twenty half-sib families (12 to 141 progeny) were used in the regression analysis with six families being excluded due to small family size.

zero values. We explored values of x of 1 or 15, that is, ca. half the measurement increment for the trait, to give LFEC₁ and LFEC₁₅. Log-transformed *Nematodirus* and *Strongyles* FEC values will thereafter be referred to as LN₁, LN₁₅, LS₁ and LS₁₅, respectively. Furthermore, because of the large proportion of zero FEC values, FEC was also analysed as a binary trait (0 or 1) to give traits S_{bin} and N_{bin}.

Some flocks showed no evidence for nematode infestation at the time of sampling, that is, all animals had a zero count for either *Nematodirus* or *Strongyles* FEC. When this happened all animals from the flock were eliminated from the analysis of the FEC category with zero values.

Genotyping

Genotyping was done using multiplex microsatellite panels developed around the regions identified in the previous studies on OAR3 and OAR14 in Blackface sheep (Davies *et al.*, 2006). This comprised a panel of seven microsatellite markers (KD103, BL4, IFNG, MAF23, CSRD111, BM6433 and BM8230) around the distal end of OAR3 and five microsatellite markers on OAR14 (INRA63, CSAP27, CSRD63, LSCV30 and BM6507). All microsatellite information is available at the 'Australian Sheep Gene Mapping website' (<http://rubens.its.unimelb.edu.au/~jillm/jill.htm>).

Statistical analyses for QTL verification

The relative marker order and position were verified using CRI-MAP (Green *et al.*, 1990). QTL analyses were initially performed by half-sib regression interval mapping techniques (Knott *et al.*, 1996) using GridQTL software (Seaton *et al.*, 2006). At each position of the chromosome region in question, a QTL effect within family is included into the model by regressing the offspring phenotypes on to their inheritance probabilities. To test if a QTL is segregating at a given position, an F-ratio of the full model including the QTL effect is calculated across all families and the location of the putative QTL is assigned to the position with the largest F-value. The 5% chromosome region-wide significance was calculated by permutations testing using at least 5000 permutations (Churchill and Doerge, 1994). Breeds were analysed separately, but within each breed all families were analysed simultaneously. Other effects fitted in each analysis included flock, year, sex, litter size born and/or reared and age of ewe. In cases where significant QTL were detected, further models were fitted to test the hypothesis of multiple QTL. The proportion of phenotypic variance due to QTL was estimated as $4(1 - MS_{full}/MS_{reduced})$ (Knott *et al.*, 1996) where MS is the residual mean square. In cases where a significant QTL was identified, QTL segregation in individual families was declared significant when, for that family, the test statistic (Student's t -value) for the allelic substitution effect was >2.0 . With random mating and Hardy Weinberg equilibrium, the allelic substitution effect would be equivalent to $a + d(1 - 2p)$ where a and d are additive and dominance effects and p is the frequency of the favourable allele (Falconer and Mackay, 1997).

Interval mapping QTL analysis using the OAR3 and OAR14 markers was also used to test for evidence for QTL for growth and carcass traits, as these phenotypes were also available for all the animals. The same statistical models were used as for the FEC data.

Variance component analysis (VCA) using ASREML software (Gilmour *et al.*, 2009) was carried out in the Texel data, this data set being sufficiently large for this analytical approach. This basic mixed linear model comprised the fixed effects described above and a random effect describing additive polygenic variation. To test for the presence of a QTL, a random term for an additive QTL was included in the basic model as follows:

$$y = X\beta + Zu + Zv_q + e$$

where y is the vector of phenotypes with β , u , v_q and e being vectors of fixed effects, additive polygenic, additive QTL effects and residuals, respectively, with incidence matrices X and Z . The terms u , v_q and e were assumed to be multivariate, normally distributed: $N(0, A\sigma_a^2)$, $N(0, G\sigma_{vq}^2)$ and $N(0, I\sigma_e^2)$, respectively. Here A is the numerator relationship matrix and G is the identity-by-descent matrix estimated by a Markov chain Monte Carlo using the Loki program (Heath, 1997) calculated for a putative QTL position.

QTL detection in the VCA method was carried out by calculating G at 1 cM intervals and the best estimate of the QTL position was assumed to be at the peak likelihood within the tested region. The significance of the QTL was tested using a log likelihood ratio test (LRT), comparing the QTL model with an equivalent model without a QTL. The test statistic was $-2[\ln L_{(QTL)} - \ln L_{(no\ QTL)}]$ where L_0 is the likelihood of each model. Critical values for the LRT were taken from $\frac{1}{2}\chi^2_{(1)}$ (Self and Liang, 1987) since the null hypothesis represents a boundary value for the variance component.

Results

Marker map order

Two microsatellite markers (IFNG and BM8230) on OAR3 were observed to be monomorphic during panel development and were subsequently dropped from the panel used for further genotyping. The map order calculated for OAR3 using CRI-MAP software (Green *et al.*, 1990) was the same as that published on the Australian website for both the Suffolk and Texel sheep. However, the calculated map order for OAR14 was not the same for markers LSCV30 and CSRD63 in the Suffolk sheep. A map with four markers only was subsequently used after omitting marker CSRD63 since its inclusion gave an abnormal QTL profile for the Suffolk animals. The calculated linkage maps (Green *et al.*, 1990) were graphically represented using the software developed by Voorrips (2002), and their genetic distances (cM) are presented in Figure 1. In addition, shown are the locations of the QTL detected using regression analyses.

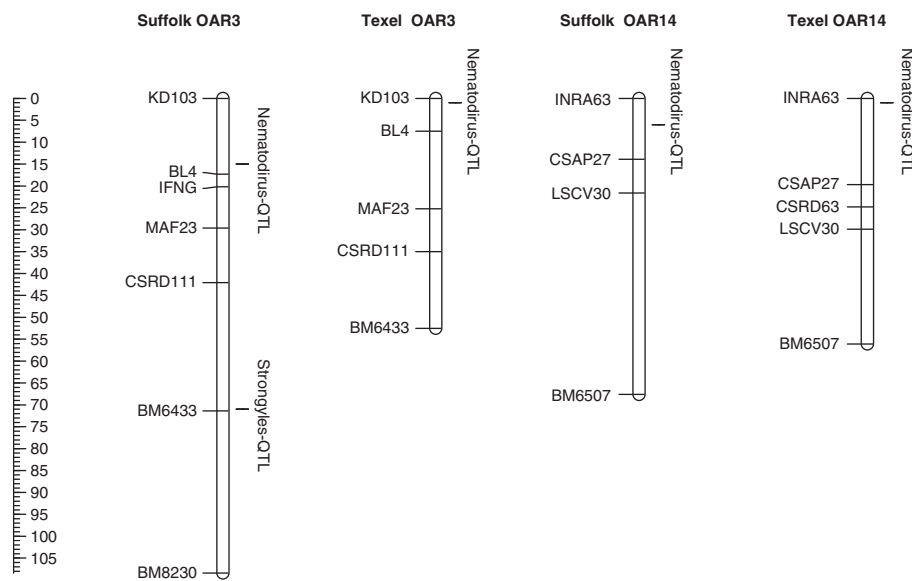

Figure 1 Best estimated positions of the genotyped markers on the Suffolk and Texel sheep linkage map.

Table 2 Summary statistics from QTL regression analyses for FEC on OAR3 and OAR14 in the Suffolk and Texel sheep populations

Breed	Chromosome	Description	Transformation	
Suffolk	3	<i>Nematodirus</i>	LN ₁	LN ₁₅
		Position (cM)	15	15
		h ² _{QTL}	0.22	0.20
	Significance level	*	*	
	14	<i>Strongyles</i>	LS ₁	LS ₁₅
		Position (cM)	71	71
h ² _{QTL}		0.18	NA	
Significance level	*	ns		
Texel	3	<i>Nematodirus</i>	LN ₁	LN ₁₅
		Position (cM)	0	2
		h ² _{QTL}	0.10	0.10
	Significance level	*	ns	

QTL = quantitative trait loci; FEC = faecal egg counts; OAR = ovine chromosome; LN₁ = ln(*Nematodirus* FEC + 1); LN₁₅ = ln(*Nematodirus* FEC + 1); LS₁ = ln(*Strongyles* FEC + 1); LS₁₅ = ln(*Strongyles* FEC + 1); NA = not applicable; MS = residual mean square.

h²_{QTL} was calculated as 4(1 - MS_{full}/MS_{reduced}); Knott *et al.*, 1996).

*Denotes the 5% region-wide significance level.

QTL for *Nematodirus* FEC from regression analyses

QTL for *Nematodirus* FEC were found to be segregating on OAR3 at 5% chromosome region-wide significance threshold in both Suffolk and Texel sheep (Table 2). Three out of nine Suffolk half-sib families were segregating for the *Nematodirus* OAR3 FEC QTL with estimated allelic substitution effects (Falconer and Mackay, 1997) ranging from 2.01 to 4.01 (log-transformed FEC units) for LN₁ and LN₁₅ (Table 3) in these families. In the Texel breed, the *Nematodirus* OAR3 QTL was also segregating in three families, and the estimates

of allelic substitution varied from 1.58 to 2.88 for LN₁ in segregating families (Table 5).

On OAR14, we found a *Nematodirus* QTL segregating in the Suffolk breed at the 5% chromosome region-wide significance (Table 2). This QTL was attributable to a single half-sib family, with an estimated allelic substitution effect of 2.04 for LN₁ and 0.85 for LN₁₅ (Table 3) and it explained 0.13 to 0.16 of the phenotypic variation depending on the transformation.

QTL for *Strongyles* FEC from regression analyses

Of the eight Suffolk half-sib families analysed for *Strongyles* FEC, two were identified as segregating for a *Strongyles* OAR3 QTL, with estimates of allelic substitution effects being 1.39 and 1.50 for LS₁ (Table 3). Further analysis, in one large Suffolk half-sib family with 106 progeny, identified two putative *Strongyles* OAR3 FEC QTL segregating at 5% chromosome region-wide when a two QTL model was fitted (data not shown). These QTL mapped to two different positions (0 v. 88 cM) with allele substitution of 0.87 ± 0.38 and 1.92 ± 0.74, with both QTL significantly (P < 0.05) different from zero.

QTL for other traits from regression analyses

In the Texel breed, we also identified a scanning weight QTL segregating at 5% chromosome region-wide on OAR14 (Table 4). The QTL was significant in four families and the estimated allelic substitution effects ranged from 2.32 to 7.50 kg. In the Suffolk sheep, a QTL for scanning weight was found segregating at 5% chromosome region-wide on OAR3.

VCA analyses

The results of VCA for FEC traits in the Texel sheep are presented in Table 6, including results for the binary traits. In agreement with the regression analyses, there was evidence for a *Nematodirus* FEC QTL segregating at 5% chromosome

Table 3 Estimated OAR3 and OAR14 QTL allelic substitution effects for log-transformed *Nematodirus* FEC (LN_1 and LN_{15}) and *Strongyles* FEC (LS_1 and LS_{15}) in Suffolk sheep

Chromosome	Trait		LN_1			LN_{15}		
	Sire family	Estimate	s.e.	t-value	Estimate	s.e.	t-value	
3	1	3.21	2.00	1.61	1.30	0.81	1.62	
	2	2.80	1.23	2.27	1.19	0.50	2.38	
	3	0.95	1.19	0.80	0.29	0.48	0.61	
	4	0.11	0.43	0.25	0.05	0.17	0.27	
	5	1.06	1.10	0.96	0.40	0.44	0.89	
	6	4.01	1.49	2.69	1.48	0.60	2.45	
	7	0.20	0.62	0.32	0.09	0.25	0.37	
	8	0.40	0.61	0.66	0.11	0.25	0.44	
	9	2.01	0.99	2.04	0.83	0.40	2.10	
14	1	1.77	1.64	1.08	0.602	0.67	0.89	
	2	2.04	0.63	3.24	0.85	0.25	3.36	
	3	0.53	1.90	0.28	0.28	0.80	0.35	
	4	0.54	0.90	0.60	0.11	0.34	0.30	
	5	0.05	2.49	0.02	0.00	1.05	0.00	
	6	0.73	1.60	0.46	0.02	0.67	0.03	
	7	2.09	1.50	1.40	1.19	0.63	1.90	
	Trait		LS_1			LS_{15}		
3	3	1.00	1.07	0.93	ns	ns	ns	
	4	1.39	0.49	2.83	ns	ns	ns	
	5	2.13	1.11	1.93	ns	ns	ns	
	7	1.31	0.95	1.38	ns	ns	ns	
	8	1.50	0.63	2.39	ns	ns	ns	
	9	0.36	2.06	0.18	ns	ns	ns	
	10	0.12	0.78	0.16	ns	ns	ns	
	11	1.62	2.35	0.69	ns	ns	ns	

OAR = ovine chromosome; QTL = quantitative trait loci; FEC = faecal egg counts; $LN_1 = \ln(\text{Nematodirus FEC} + 1)$; $LN_{15} = \ln(\text{Nematodirus FEC} + 1)$; $LS_1 = \ln(\text{Strongyles FEC} + 1)$; $LS_{15} = \ln(\text{Strongyles FEC} + 1)$.

ns indicates that there is no evidence of a QTL segregating. Values shown in bold are nominally significant ($t > 2.0$). All allelic substitution effects are in log-transformed FEC units.

Table 4 Summary statistics from QTL regression analyses for scanning weight on OAR3 and OAR14 in the Suffolk and Texel sheep populations

Breed	Chromosome	Description	Scanning weight QTL
Suffolk	3	Position (cM)	49
		h^2_{QTL}	0.24
		Significance level	*
Texel	14	Position (cM)	24
		h^2_{QTL}	0.11
		Significance level	*

QTL = quantitative trait loci; OAR = ovine chromosome; MS = residual mean square.

h^2_{QTL} was calculated as $4(1 - MS_{full}/MS_{reduced})$; Knott *et al.*, 1996).

*Denotes the 5% region-wide significance level.

region-wide level, depending on trait definition, on both OAR3 and OAR14. The *Strongyles* FEC QTL segregated at 5% chromosome region-wide level on OAR3 in contrast to the regression analyses where no significant QTL was seen for this trait. The proportion of phenotypic variance explained by the QTL varied from 0.08 to 0.14 and 0.06 to 0.13 for the *Nematodirus* FEC QTL and *Strongyles* FEC QTL, respectively, depending on the transformation.

Discussion

Although mixed parasite infections can cause challenges for statistical analyses and interpretation, such data from grazing conditions are also a strength as this is the natural challenge faced by sheep, and hence represent the conditions under which genetic improvement of parasite resistance will take place. Natural mixed species nematode infections in the United Kingdom are complex. Generally, these infections may comprise the following genera: *Trichostrongylus*, *Cooperia*, *Bunostomum*, *Ostertagia*, *Teladorsagia*, *Haemonchus* and *Nematodirus* spp. (Stear *et al.*, 1998), although their composition are likely to vary with regional climate and pasture management practices. However, some notable features are apparent, for example, larval stages of *Nematodirus* have been reported to be more pathogenic than the adult worms, unlike *Strongyles* infections where the adult worm is considered important (McKenna, 1981). This aspect of their biology, combined with the fact that *Nematodirus* and *Strongyles* eggs are visually separable, led us to treat *Nematodirus* and *Strongyles* FEC as separate traits.

Lower FEC for *Nematodirus* than for *Strongyles* in our study (Table 1) are consistent with those reported elsewhere

(Bishop *et al.*, 2004; Davies *et al.*, 2006; Salle G. and Bishop SC, 2007 unpublished results), although both types of FEC are heritable. Reported genetic correlations between *Nematodirus* and *Strongyles* FEC are invariably positive and moderate to strong, ranging from 0.49 to 0.93, across a range of environments and breeds (Bishop *et al.*, 2004; Morris *et al.*, 2004; Wolf *et al.*, 2008). These estimated genetic correlations imply some common genetic mechanisms responsible for resistance to *Strongyles* and *Nematodirus*; hence, it may

be hypothesised that some of the QTL underlying genetic variation in *Nematodirus* and *Strongyles* FEC may be in common. However, in this study, no families had segregating QTL for both *Nematodirus* and *Strongyles* FEC. In addition, the *Nematodirus* FEC QTL and *Strongyles* FEC QTL on OAR3 in the Suffolk breed mapped to positions 15 and 71 cM, respectively, and the QTL segregated in different families for these two traits. This suggests that these are probably two separate QTL.

Table 5 Estimated OAR3 QTL allelic substitution effects for log-transformed *Nematodirus* FEC (LN₁) in Texel sheep

Sire family	Estimate	s.e.	t-value
1	0.85	0.70	1.22
2	0.05	1.01	0.05
3	0.69	1.24	0.55
4	0.22	0.53	0.41
5	0.48	0.53	0.91
6	0.22	0.75	0.29
7	0.15	0.60	0.25
8	0.10	0.58	0.17
9	2.18	0.99	2.20
10	0.43	0.48	0.91
11	4.06	2.72	1.49
12	0.28	0.74	0.37
13	1.10	0.95	1.16
14	1.58	0.48	3.31
15	2.88	0.78	3.72
16	0.47	0.58	0.82
17	0.61	0.92	0.66
18	0.48	0.93	0.51
19	0.62	0.83	0.75
20	0.44	0.52	0.85

OAR = ovine chromosome; QTL = quantitative trait loci; FEC = faecal egg counts; LN₁ = ln(*Nematodirus* FEC + 1). Values shown in bold are nominally significant ($t > 2.0$). All allelic substitution effects are in log-transformed FEC units.

Our results confirm that QTL for both *Nematodirus* and *Strongyles* FEC on OAR3, observed in Blackface sheep (Davies *et al.*, 2006), are also segregating in the Suffolk and Texel breeds. These QTL were observed despite the fact that our data were from natural infections collected on several commercial flocks across the United Kingdom, with the nature of the mixed species parasite challenge expected to differ across flocks. We also confirmed the *Nematodirus* FEC QTL on OAR14, using the regression methods, in the Suffolk sheep but not in the Texel sheep. However, using all the pedigree relationships with VCA methodology, a similar QTL was also found to be segregating in the Texel breed. The use of all available pedigree relationship information in the VCA approach may have resulted in more power to detect *Strongyles* FEC QTL on OAR3 and *Nematodirus* FEC QTL on OAR14. However, it should be noted that the estimated QTL heritabilities are often larger than the polygenic heritabilities, suggesting that the QTL effects are somewhat overestimated.

The published studies for OAR3 QTL affecting FEC include naturally infected, experimental Blackface sheep (Davies *et al.*, 2006), unmanaged Soay sheep predominantly parasitised by *Teladorsagia circumcincta* (Coltman *et al.*, 2001) and by coccidia (Beraldi *et al.*, 2007), *Trichostrongylus colubriformis* in divergent lines of nematode resistant selected sheep (Beh *et al.*, 1998 and 2002), *Haemonchus contortus* on OAR3 and OAR14 (among others; Beh *et al.*, 1998) and natural challenge in Romney selection lines (Paterson *et al.*, 2001). Although a QTL on OAR3 appears to be a common

Table 6 VCA for *Nematodirus* and *Strongyles* FEC in Texel sheep

Breed	Chromosome	Trait	h ² _p	h ² _q	s.e.	Position	LR	Significance level	
Texel	3	<i>Nematodirus</i>							
		LN ₁	0.04	0.14	0.10	41	3.78	*	
		LN ₁₅	0.16	0.08	0.07	52	2.42	ns	
		N _{bin}	0.04	0.14	0.10	44	4.44	*	
		<i>Strongyles</i>							
		LS ₁	0.00	0.09	0.06	21	2.74	*	
		LS ₁₅	0.13	0.13	0.09	21	2.77	*	
		S _{bin}	0.10	0.06	0.06	16	1.46	ns	
		14	<i>Nematodirus</i>						
			LN ₁	0.07	0.10	0.08	0	2.90	*
LN ₁₅	0.15		0.06	0.06	0	1.43	ns		
N _{bin}	0.06		0.13	0.09	0	3.97	*		

VCA = variance component analysis; FEC = faecal egg counts; h²_p = estimate of polygenic heritability; h²_q = estimate of the QTL heritability; LR = log likelihood ratio; LN₁ = ln(*Nematodirus* FEC + 1); LN₁₅ = ln(*Nematodirus* FEC + 1); LS₁ = ln(*Strongyles* FEC + 1); LS₁₅ = ln(*Strongyles* FEC + 1). Position is the QTL position on the chromosome segment (cM), LR is $-2[\ln L_{(QTL)} - \ln L_{(no\ QTL)}]$ and significance level is given by the critical values taken from $\frac{1}{2}\chi^2_{(1)}$ (Self and Liang, 1987). N_{bin} and S_{bin} are *Nematodirus* and *Strongyles* FEC expressed as binary traits, that is, presence or absence of eggs.

finding across studies, not all have been in the same segment and some large-scale studies (e.g. Crawford *et al.*, 2006) have failed to find any evidence on chromosome 3. Although no causative mutation has been identified for the FEC OAR3 QTL, the effect is often presumed to be mediated through *INFG* in sheep (Stear *et al.*, 2009).

Two QTL studies have reported an OAR14 FEC QTL, one in Blackface sheep (Davies *et al.*, 2006) and the other in lactating Spanish milk sheep (Gutierrez-Gil *et al.*, 2009), but the QTL positions were different in these two studies and neither study suggested any possible candidate genes underlying the QTL. Recently, however, in a comparative genomics study of TLR signalling in five species, Jann *et al.* (2009) assigned IRF3 using both *in silico* and radiation hybrid mapping to OAR14, within the region covered by our markers. The study of Jann *et al.* (2009) mapped IRF3 to a region affecting health traits in five species with host QTL controlling a wide range of pathogens, making it a strong candidate gene for our OAR14 QTL.

An important question from this study is whether QTL detected for nematode resistance and performance are pleiotropic. In general, a QTL affecting two traits may represent a single pleiotropic locus or two single-trait loci in close linkage (Gardner and Latta, 2007), and QTL studies cannot distinguish linkage from pleiotropy in cases when there is low resolution of QTL position (≥ 10 cM). In this study, the FEC QTL also mapped to the same regions as QTL affecting growth traits on OAR3 in the Suffolk and OAR14 in the Texel. One Suffolk half-sib family had QTL segregating at 5% chromosome region-wide level for scanning weight and fat depth, with this same family plus another family segregating at 1% chromosome region-wide level in the same location for average daily gain (results not shown). Thus, these three QTL may well be the same QTL. However, although we observed both growth and FEC QTL on OAR3, these QTL were segregating in different families. Thus, there is little evidence that these growth and FEC QTL map to a single pleiotropic locus. We also found evidence for both OAR14 muscle depth QTL and *Nematodirus* OAR14 FEC segregating at 5% chromosome region-wide level in one Suffolk half-sib family. The favourable allele in this family was linked to a decrease in both FEC and muscle depth, that is, desirable for low FEC and unfavourable for muscle depth. *A priori*, we would expect pleiotropic QTL for FEC and performance if there were strong genetic correlations between these traits. However, the published evidence is very variable with correlations seeming to differ between studies as the severity of challenge and parasite species differ (Bishop and Stear, 2003; Bishop *et al.*, 2004; Morris *et al.*, 2004), and often being close to zero. Thus, it is unclear whether QTL that map to the same region in this study are pleiotropic or merely linked.

In summary, we have shown that previously reported FEC QTL on OAR3 and OAR14 in Blackface sheep and other breeds are also segregating in commercial Suffolk and Texel sheep. In addition, QTL for growth traits are also seen at these positions, and possibly some of these are pleiotropic QTL. As FEC measurement in the field poses an onerous task

and one, which is difficult to implement routinely under commercial conditions, an immediate challenge is to identify a route to implementation for these QTL. In order for these QTL to be exploited in breeding programmes, there is a need to identify single nucleotide polymorphisms that are in population wide linkage disequilibrium with the causative mutations, or perhaps even attempt to identify the causative mutations, themselves. The confirmation that FEC QTL segregate in the same position in three widely used breeds widens their potential applicability to purebred Blackface, Suffolk, Texel sheep, with benefits likely to be observed in their commercial crossbred progeny.

Acknowledgements

The project is funded through the LINK SLP programme, with inputs from Defra, SEERAD, EBLEX, HCC, MLC and, Suffolk and Texel breeders.

References

- Beh KJ, Callaghan MJ, Hulme DJ, Leish Z, Diianno K and Lenane I 1998. A search for genes affecting gastrointestinal parasite resistance in sheep. *Animal Genetics* 29, 67 [Originally published in 'Proceedings of 26th International conference on animal genetics, August 9–14, 1998, Auckland, New Zealand, pp. 102–103].
- Beh KJ, Hulme DJ, Callaghan MJ, Leish Z, Lenane I, Windon RG and Maddox JF 2002. A genome scan for quantitative trait loci affecting resistance to *Trichostrongylus colubriformis* in sheep. *Animal Genetics* 33, 97–106.
- Beraldi D, McRae AF, Gratten J, Pilkington JG, Slate J, Visscher PM and Pemberton JM 2007. Quantitative trait loci (QTL) mapping of resistance to strongyles and coccidia in the free-living Soay sheep (*Ovis aries*). *International Journal for Parasitology* 37, 121–129.
- Bishop SC and Stear MJ 2001. Inheritance of faecal egg counts during early lactation in Scottish Blackface ewes facing mixed, natural nematode infections. *Animal Science* 73, 389–395.
- Bishop SC and Stear MJ 2003. Modeling of host genetics and resistance to infectious diseases: understanding and controlling nematode infections. *Veterinary Parasitology* 115, 147–166.
- Bishop SC, Jackson F, Coop RL and Stear MJ 2004. Genetic parameters for resistance to nematode infections in Texel lambs and their utility in breeding programmes. *Animal Science* 78, 185–194.
- Buitkamp J, Feichtlbauer-Huber P and Stear MJ 1999. Association between MHC class II alleles and resistance to the parasitic nematode *Ostertagia circumcincta*. *Archiv Fur Tierzucht-Archives of Animal Breeding* 42, 11–21.
- Charon KM, Moskwa B, Rutkowski R, Gruszczynska J and Swiderek W 2002. Microsatellite polymorphism in DRB 1 gene (MHC class II) and its relation to nematode faecal egg count in Polish Heath Sheep. *Journal of Animal and Feed Sciences* 11, 47–58.
- Churchill GA and Doerge RW 1994. Empirical threshold values for quantitative trait mapping. *Genetics* 138, 963–971.
- Coles GC, Jackson F, Pomroy WE, Prichard RK, von Samson-Himmelstjerna G, Silvestre A, Taylor MA and Vercruyse J 2006. The detection of anthelmintic resistance in nematodes of veterinary importance. *Veterinary Parasitology* 136, 167–185.
- Coltman DW, Wilson K, Pilkington JG, Stear MJ and Pemberton JM 2001. A microsatellite polymorphism in the gamma interferon gene is associated with resistance to gastrointestinal nematodes in a naturally-parasitized population of Soay sheep. *Parasitology* 122, 571–582.
- Crawford AM, Paterson KA, Dodds KG, Tascon CD, Williamson PA, Thomson MR, Bisset SA, Beattie AE, Greer GJ, Green RS, Wheeler R, Shaw RJ, Knowler K and McEwan JC 2006. Discovery of quantitative trait loci for resistance to parasitic nematode infection in sheep: I. Analysis of outcross pedigrees. *BMC Genomics* 7, 178.

- Davies G, Stear MJ, Benothman M, Abuagob O, Kerr A, Mitchell S and Bishop SC 2006. Quantitative trait loci associated with parasitic infection in Scottish blackface sheep. *Heredity* 96, 252–258.
- Falconer DS and Mackay TFC 1997. *Introduction to quantitative genetics*. Longman Press Harlow, Essex, UK.
- Gardner KM and Latta RG 2007. Shared quantitative trait loci underlying the genetic correlation between continuous traits. *Molecular Ecology* 16, 4195–4209.
- Gilmour AR, Gogel BJ, Cullis BR and Thompson R 2009. *ASReml user guide release 3.0*. VSN International Ltd, Hemel Hempstead, UK.
- Green P, Falls K and Crooks S 1990. *Cri-map version 2.4*. Washington University School of Medicine, St. Louis, MO, USA.
- Gutierrez-Gil B, Perez J, Alvarez L, Martinez-Valladares M, de la Fuente LF, Bayon Y, Meana A, San Primitivo F, Rojo-Vazquez FA and Arranz JJ 2009. Quantitative trait loci for resistance to trichostrongylid infection in Spanish Churra sheep. *Genetics Selection Evolution* 41, 46.
- Heath SC 1997. Markov chain Monte Carlo segregation and linkage analysis for oligogenic models. *American Journal of Human Genetics* 61, 748–760.
- Jann OC, King A, Corrales NL, Anderson SI, Jensen K, Ait-ali T, Tang HZ, Wu CH, Cockett NE, Archibald AL and Glass EJ 2009. Comparative genomics of Toll-like receptor signalling in five species. *BMC Genomics* 10, 216.
- Knott SA, Elsen JM and Haley CS 1996. Methods for multiple-marker mapping of quantitative trait loci in half-sib populations. *Theoretical and Applied Genetics* 93, 71–80.
- Matika O, Sechi S, Pong-Wong R, Houston RD, Clop A, Woolliams JA and Bishop SC 2010. Characterization of OAR1 and OAR18 QTL associated with muscle depth in British commercial terminal sire sheep. *Animal Genetics*, doi: 10.1111/j.1365-2052.2010.02121.x.
- McCoy MA, Edgar HWJ, Kenny J, Gordon AW, Dawson LER and Carson AF 2005. Evaluation of on-farm faecal worm egg counting in sheep. *Veterinary Record* 156, 21–23.
- McKenna PB 1981. The diagnostic-value and interpretation of fecal egg counts in sheep. *New Zealand Veterinary Journal* 29, 129–132.
- Morris CA, Bisset SA, Vlassoff A, West CJ and Wheeler M 2004. Genetic parameters for *Nematodirus* spp. egg counts in Romney lambs in New Zealand. *Animal Science* 79, 33–39.
- Nieuwhof GJ and Bishop SC 2005. Costs of the major endemic diseases of sheep in Great Britain and the potential benefits of reduction in disease impact. *Animal Science* 81, 23–29.
- Paterson KA, McEwan JC, Dodds KG, Morris CA and Crawford AM 2001. Fine mapping a locus affecting host resistance to internal parasites in sheep. *Proceedings of Association for the Advancement of Animal Breeding and Genetics*, 14, 91–94.
- Seaton G, Hernandez J, Grunchev JA, White I, Allen J, De Koning DJ, Wei W, Berry D, Haley C and Knott S 2006. *GridQTL: A Grid Portal for QTL Mapping of Compute Intensive Datasets*. Proceedings of the 8th World Congress on Genetics Applied to Livestock Production. 13–18 August, 2006. Belo Horizonte, Brazil, Article 27-07.
- Self SG and Liang KY 1987. Asymptotic properties of maximum-likelihood estimators and likelihood ratio tests under non standard conditions. *Journal of the American Statistical Association* 82, 605–610.
- Stear MJ, Boag B, Cattadori I and Murphy L 2009. Genetic variation in resistance to mixed, predominantly *Teladorsagia circumcincta* nematode infections of sheep: from heritabilities to gene identification. *Parasite Immunology* 31, 274–282.
- Stear MJ, Bairden K, Bishop SC, Gettinby G, McKellar QA, Park M, Strain S and Wallace DS 1998. The processes influencing the distribution of parasitic nematodes among naturally infected lambs. *Parasitology* 117, 165–171.
- Voorrips RE 2002. *MapChart: Software for the graphical presentation of linkage maps and QTLs*. *Journal of Heredity* 93, 77–78.
- Whitlock HV 1948. Some modifications of the McMaster helminth egg-counting technique and apparatus. *Journal of the Council for Scientific and Industrial Research, Australia* 21, 177–180.
- Wolf BT, Howells K, Nakielny C, Haresign W, Lewis RM, Davies O and Davies MH 2008. Genetic parameters for strongyle and *Nematodirus* faecal egg counts in lambs and their relationships with performance traits. *Livestock Science* 113, 209–217.