



THE UNIVERSITY *of* EDINBURGH

Edinburgh Research Explorer

## Royal succession and kingship among the Picts

**Citation for published version:**

Evans, N 2008, 'Royal succession and kingship among the Picts', *The Innes Review*, vol. 59, no. 1, pp. 1-48. <https://doi.org/10.3366/E0020157X08000140>

**Digital Object Identifier (DOI):**

[10.3366/E0020157X08000140](https://doi.org/10.3366/E0020157X08000140)

**Link:**

[Link to publication record in Edinburgh Research Explorer](#)

**Document Version:**

Publisher's PDF, also known as Version of record

**Published In:**

The Innes Review

**Publisher Rights Statement:**

© Evans, N. (2008). Royal succession and kingship among the Picts. *The Innes Review*, 59(1), 1-48doi: 10.3366/E0020157X08000140

**General rights**

Copyright for the publications made accessible via the Edinburgh Research Explorer is retained by the author(s) and / or other copyright owners and it is a condition of accessing these publications that users recognise and abide by the legal requirements associated with these rights.

**Take down policy**

The University of Edinburgh has made every reasonable effort to ensure that Edinburgh Research Explorer content complies with UK legislation. If you believe that the public display of this file breaches copyright please contact [openaccess@ed.ac.uk](mailto:openaccess@ed.ac.uk) providing details, and we will remove access to the work immediately and investigate your claim.



Nicholas Evans

## Royal succession and kingship among the Picts

**Key words:** Picts; succession; kingship; Bede; medieval; Scotland.

When we consider the history of the Picts we are faced with the perennial challenge for the early medievalist of deciding whether the fragments of evidence which survive are representative of the reality of Pictish society, or whether they provide us with distortions, based on patterns of survival. This issue is as relevant to the subject of royal succession as it is to other aspects of Pictish history. The debate over whether the Picts practised a matrilineal system, with the son of the previous king's sister becoming the next king, or whether it was a patrilineal system, with the kingship generally passing through the male line, has dominated the discussion of Pictish succession. Until the 1980s, the matrilineal thesis was virtually unquestioned, and accepted by scholars including F. T. Wainwright, Marjorie Anderson, and Isabel Henderson.<sup>1</sup> The bases for this view were the accounts of the Pictish settlement of northern Britain in Bede's 'Ecclesiastical History of the English People' and Irish texts written throughout the medieval period, but mainly surviving in versions from the twelfth century or later.<sup>2</sup> In these sources it was claimed that the Picts went to Ireland before arriving in northern Britain, and that they obtained wives from the Irish, with some versions stating that this was done on condition that the succession went through the female line. Other sources which did not openly discuss the nature of Pictish

---

<sup>1</sup> The main studies up to the mid-1980s are F. T. Wainwright, 'The Picts and the problem', in *The Problem of the Picts*, ed. F. T. Wainwright (Edinburgh, 1955), 25–8; Isabel Henderson, *The Picts* (London, 1967), 31–3; Anthony Jackson, 'Pictish social structure and symbol-stone. An anthropological assessment', *Scottish Studies* 15 (1971), 121–40; Marjorie O. Anderson, *Kings and Kingship in Early Scotland* (Edinburgh, 1973; rev. edn 1980), 165–78, 187–8, 191–6, 203; D. P. Kirby, '... per universas Pictorum provincias', in *Famulus Christi. Essays in Commemoration of the Thirteenth Centenary of the Birth of the Venerable Bede*, ed. Gerald Bonner (London, 1976), 286–324, at 298–311; Alexander Boyle, 'Matrilineal succession in the Pictish monarchy', *Scottish Historical Review* [hereafter *SHR*] 56 (1977), 1–10; M. Miller, 'The last century of Pictish succession', *Scottish Studies* 23 (1979), 39–67, at 51–6; Molly Miller, "'Matrilineal by treaty": the Pictish foundation-legend', in *Ireland in Early Mediaeval Europe. Studies in Memory of Kathleen Hughes*, ed. Dorothy Whitelock, Rosamond McKitterick and David Dumville (Cambridge, 1982), 133–61.

<sup>2</sup> Bede, *Historia Ecclesiastica Gentis Anglorum* [hereafter *HE*], i.1, ed. and trans. Bertram Colgrave and R. A. B. Mynors, *Bede's Ecclesiastical History of the English People* (Oxford, 1969; repr. with corrections 1991), 16–19; for the Irish accounts, see Gearóid S. Mac Eoin, 'On the Irish legend of the origin of the Picts', *Studia Hibernica* 4 (1964), 138–54; Miller, 'Matrilineal by treaty', 143–50.

succession, particularly the Irish chronicles and the Pictish king-lists, were then interpreted by scholars in relation to these accounts and were thought to support them.

The alternative view of Pictish succession, that the Picts did not practise matrilineal succession, was proposed in 1984 by Alfred Smyth in his book, *Warlords and Holy Men*, disputed by David Sellar soon after, and has been restated with different arguments by Alex Woolf and Alasdair Ross.<sup>3</sup> The latter two scholars independently came to the conclusion that succession through the female line was exceptional, referring to the sons of Derelei, who ruled in the late seventh and early eighth centuries, rather than all Pictish kings. This theory minimised the importance of Bede's account, and rejected the Irish tales, proposing alternative views of Pictish succession: Woolf argued that there was a patrilineal dynasty in the seventh century, and that the succession was generally not dissimilar to that of other kingships in northern Europe. Ross, on the other hand, followed Smyth in proposing a kingship rotating between different groups, and for the intrusion of outsiders into the kingship by foreign rulers, such as the kings of Northumbria from the 650s to 685. However, it is probably fair to state that both the proponents and opponents of the matrilineal theory have concentrated on the issue of whether succession was through the male or female line, a focus found in the medieval texts which addressed the subject.

The intention of this article is not to decide whether the Picts practised matrilineal or patrilineal succession. Instead I will focus on other aspects of the succession, since, even though matrilineal succession has been rejected by some scholars, the concentration on this issue may have led to the relative neglect of other facets. While many important points have been made before about the sources, by re-examining the evidence, in particular Bede's 'Ecclesiastical History', the Pictish king-lists and Irish chronicles, in another framework, a different depiction of succession, as well as of Pictish kingship and political structure, can be produced.

*The account in Bede's 'Ecclesiastical History of the English People'*

As has already been mentioned, Bede's 'Ecclesiastical History', finished in A.D. 731, includes an account of the Pictish settlement in Book i.1, the introduction to Britain and its peoples. In this Bede states:

*Cumque uxores Picti non habentes peterent a Scottis, ea solum  
condicione dare consenserunt, ut ubi res ueniret in dubium,*

---

<sup>3</sup> Alfred P. Smyth, *Warlords and Holy Men. Scotland AD 80–1000* (Edinburgh, 1984), 57–75; W. David H. Sellar, 'Warlords, holy men and matrilineal succession' (review article), *IR* 36 (1985), 29–43, at 35–41; Alex Woolf, 'Pictish matrilineal reconsidered', *IR* 49 (1998), 147–67; Alasdair Ross, 'Pictish matrilineal?', *Northern Studies* 34 (1999), 11–22.

*magis de feminea regum prosapia quam de masculina regem sibi eligerent; quod usque hodie apud Pictos constat esse seruatum.*<sup>4</sup>

‘As the Picts had no wives, they asked the Irish for some; the latter consented to give them women, only on condition that, in all cases of doubt, they should elect their kings from the female royal line rather than the male; and it is well-known that the custom has been observed among the Picts to this day.’<sup>5</sup>

If we ignore the statement about the selection of kings from the female rather than the male line, Bede’s account, which should probably be regarded as pretty reliable evidence derived from the Picts and common knowledge, does indicate two things.<sup>6</sup> One is that there was a Pictish royal dynasty, since Bede mentions lineages of kings. This demonstrates that at least one royal dynasty was involved, so the election of noblemen to the Pictish kingship was unlikely.<sup>7</sup> The second inference is that there were cases when the succession was and was not in doubt. Exactly what Bede meant here is not clear, but it can be reconstructed to some extent when Anglo-Saxon kingships in the period from 600 to 731, upon which he probably based his conception of normal succession practice, are studied.

In this period a single succession pattern is not found for Anglo-Saxon kingships, although succession through the male line was the rule, as Alex Woolf has noted.<sup>8</sup> Bede probably did not have a fixed view of the circumstances when the succession was not in doubt; he may have regarded this as when there was a candidate whose succession was

<sup>4</sup> *HE*, i.1, ed. Colgrave and Mynors, 18.

<sup>5</sup> *HE*, i.1, ed. Colgrave and Mynors, 19.

<sup>6</sup> I follow Woolf, ‘Pictish matriline reconsidered’, 152–3, in considering it unlikely that Bede was mistaken in his comments about Pictish royal succession. The statement that the custom was well-known indicates that at least Bede and those he had contact with in Northumbria had some knowledge of Pictish succession practice as well as that gained from his immediate Pictish source. Another issue is what kingship(s) Bede was discussing. While it is possible that Bede was referring to all Pictish kingships, it is likely that he was discussing the kingship ruled by King Nectan son of Derelei (or his successors in the 720s). This is likely to have been either the kingship of Fortriu or the over-kingship of the Picts, if these were not the same in this period.

<sup>7</sup> The translation by Colgrave and Mynors, which could imply that there was both a female and male line of kings, is somewhat unclear: it could potentially refer to succession through the daughters or sisters of kings, or that succession went to the lineage of the king’s wife, if that lineage was also considered royal. However, the crucial word, *prosapia*, is used by Bede elsewhere in *HE*, iii.1 and *HE*, v.24 for kings of the Northumbrians and Deirans, in both cases denoting the lineage of kings in the past: see Putnam Fennell Jones, *A Concordance to the Historia Ecclesiastica of Bede* (Cambridge, MA, 1929), 428. It perhaps should be translated as ‘ancestry’. Therefore, Bede seems to mean that Pictish succession (when the issue was in doubt) could be decided by a person’s female ancestry.

<sup>8</sup> Woolf, ‘Pictish matriline reconsidered’, 151–2.

obvious and unstoppable. Usually such a person would have been the brother of the previous king, as this was the single most common pattern of succession in Anglo-Saxon kingdoms.<sup>9</sup> The son of the previous king rarely succeeded immediately, apart from when his father had had a long reign of twenty years or more; in these cases the son would often have been able to establish himself as an important political figure in his own right during his father's reign.<sup>10</sup> However, a son did sometimes become king later, after someone else had succeeded his father, although the frequent succession of brothers meant that there could be many such sons of previous kings with viable claims. As well as this there were kings who came from more remote branches of the royal dynasty, and there are also some whom we cannot place genealogically.<sup>11</sup> So for Bede,

---

<sup>9</sup> Wainwright, 'The Picts', 26; Anderson, *Kings*, 165–6 n.180. Some Anglo-Saxon examples in Bede's time would have been the successions of Wulfhere (658–75) and Æthelred (675–704), sons of Penda, to the kingship of Mercia, and Eanfrith (633–4), Oswald (634–42) and Oswiu (642–70), sons of Æthelfrith, Ecgrith (670–85) and Aldfrith (685/6–705), sons of Oswiu to the kingdom of Bernicia or of all the Northumbrians: Barbara Yorke, *Kings and Kingdoms of Early Anglo-Saxon England* (London, 1990), 103–4 for Mercia, 76 for Bernicia and Northumbria. The succession of brothers was at least as, if not more, common than father-to-son succession among the Northumbrians and Mercians during Bede's own lifetime.

<sup>10</sup> See Woolf, 'Pictish matriliney reconsidered', 154–7, for a discussion of English kingships from the sixth to the ninth centuries. Focussing only on kings from 600 to the writing of Bede's *Historia Ecclesiastica*, it can be seen that in Kent there was direct father-to-son succession for the dominant East Kentish kingship from Æthelbert (d.616) to Egbert (664–73), but then, out of the kings whose relationships are identifiable, succession seems to have gone to brothers before sons: Yorke, *Kings and Kingdoms*, 33, 36. Among the East Saxons sons did sometimes immediately succeed their fathers but often in joint kingships among brothers or more distant relatives: *ibid.*, 51–3. Among the East Angles Rædwald (d. by 627) was immediately succeeded by his son Eorpwald, and Aldwulf (663–713) by his son Ælfwald (713–49), but brothers succeeded each other more often: *ibid.*, 67–9. In Northumbria Ecgrith (670–85) succeeded his father Oswiu (642–70), and Osred (705/6–16) his father Aldfrith (685/6–705), albeit with opposition from Eadwulf (705/6), but brothers, more remote kinsmen, or members of a rival dynasty, became king much more commonly from the late seventh century (for Bernicia, the relationship to the previous king was: sons, twice; brothers, three times; remote relations [perhaps unrelated?], three times; rival dynasties, twice; uncertain, once): *ibid.*, 75–9, 86–90. For Mercia the only instance of direct father-to-son succession up to 731 was when Peada succeeded his father Penda in 655 as king of the southern Mercians under Northumbrian dominance: *ibid.*, 103–4. Among the West Saxons the only clear instance of a son immediately becoming king on his father's death is that of Cenwalh (642–73), who succeeded Cynegils (611–42), although Cynegils may have been the son of Ceolwulf (594–611): *ibid.*, 133–4, 142–5.

<sup>11</sup> Remote dynastic claimants (if their claims were not fabricated) who became king before 731 included Caedwalla (685/6–8) and Ine (688–726) of the West Saxons: *ibid.*, 133–4; Æthelbald (716–57) of Mercia: *ibid.*, 103–4, 112; as well as Cenred (716–18), and Ceolwulf (729–38) of Northumbria: *ibid.*, 87–8, 90. Cases where the king's connection with the royal dynasty is not known (although this could be a result of a lack of evidence) include Eadwulf (705/6) of Northumbria: *ibid.*, 86–7, 90; Æthelheard (726–40) of the

immediate father-to-son succession was not normal, but exceptional, and probably usually would have been included under his category of when the succession came into doubt, whereas brother-to-brother succession mainly would have been when it was not uncertain. As will be seen, in this respect Pictish succession practice in Bede's time would not necessarily have seemed very different, apart from the greater importance placed on female ancestry. This he commented on because it contrasted with the more strictly patrilineal Anglo-Saxon kingships.

### *The evidence for Pictish kingdoms*

Most of our evidence for Pictish kings comes from the Pictish king-lists and the Irish chronicles. The Pictish king-lists, the only substantial texts written by the Picts themselves which survive, are found in manuscripts from the late medieval period or later. They include sixty or more kings with reign-lengths, covering over a thousand years from ancient times up to the mid- or late ninth century.<sup>12</sup> There are two main versions of the list, called *Series breuior* (SB) and *Series longior* (SL).<sup>13</sup> *Series breuior* is found in Scottish and English manuscripts of the fourteenth century or later, deriving from a common source written at some point during the reign of Alexander II (1214–49).<sup>14</sup> The other group, *Series longior*, is found in two sub-groups (SL2 and SL3) accompanying Irish manuscripts in the texts *Lebor Bretnach*, the 'British Book', and *Lebor Gabála Éirenn*,

---

West Saxons: *ibid.*, 133–4; and Ricbert (627/8–30/1) of the East Angles: *ibid.*, 67–8. Overall, most of the powerful Anglo-Saxon kings of the time that Bede was writing his *Historia Ecclesiastica* fall into these two categories.

<sup>12</sup> In this article name-forms will generally be standardised to a form in Pictish orthography from the Pictish king-lists (Nectan, Drest, Drusten, Bredei, Talorc, Talorgen, Gartnait, Cinioid, Onuist or its alternative spelling Unuist, Uurguist, Castantin, Derelei), apart from the last Pictish kings, Cináed son of Alpín and his successors up to 900 (following SL2's change to Gaelic orthography at this point, so that earlier Cinioid and Elpin are spelt Cináed and Alpín respectively), although it should be noted that *Annales Cambriae*, ed. and trans. David N. Dumville, *Annales Cambriae, A.D. 682–954: Texts A–C in Parallel*, Basic Texts for Brittonic History 1 (Cambridge, 2002) [hereafter AC], s.a. 858, 12–13, has *Ce<ni>oyth* (MS. A) and *Cenioid* (MS. B) for his obituary notice. The spellings have been applied for consistency only, rather than being the most correct forms.

<sup>13</sup> For editions of the lists, see Anderson, *Kings*, 245–9, 261–89 and *Lebor Bretnach. The Irish Version of the Historia Brittonum ascribed to Nennius*, §4, §§47–53, ed. A. G. Van Hamel (Dublin, 1932), 5–6, 82–5. For the SL and SB designations, see Miller, 'Matriline by treaty', 159–61, and Molly Miller, 'The disputed historical horizon of the Pictish king-lists', *SHR* 58 (1979), 1–34, at 1–3.

<sup>14</sup> Anderson, *Kings*, 52–67, esp. 58. John of Fordun's king-list, which is mainly derived from SB texts, may have used an earlier version than the SB archetype. I intend to discuss this in greater detail in a future publication on the Pictish king-lists.

the ‘Invasion-Book of Ireland’, of the late eleventh century or later.<sup>15</sup> It is also found in the Poppleton manuscript (SL1) written *c.*1360 in northern England.<sup>16</sup> The surviving *Series longior* witnesses derive from a text written 1058x93 or before, and the whole recension, which contains substantial additional material compared to *Series breuior*, is likely to have been created in the mid-ninth century at some point from 842/3 to 876 (probably 862x76).<sup>17</sup>

Marjorie Anderson argued that the common source of *Series longior* and *Series breuior* ended in the 720s, because of differences in the two textual groups after then.<sup>18</sup> However, most of these differences can be explained by scribal corruption made during copying and by arguing that *Series breuior* was a compilation of two manuscripts, which led to kings in the eighth century being duplicated.<sup>19</sup> As a result it is likely that the common source of SL and SB continued until 834 or later, shortly before the *Series longior* version was created. It is, therefore, possible to reconstruct, at least in part, two Pictish stages of the king-list, one being the common source of *Series breuior* and *Series longior* (written 834x76), the other the *Series longior* version itself (842/3x76).<sup>20</sup> The common source of SL and SB was created late in the Pictish period but a king-list was probably already in existence by the reign of King Gartnait son of Donuel (656?–63?), since the half-year fraction given to that king for his reign-length is indicative of contemporary recording.<sup>21</sup> The surviving king-lists, then, are derived from Pictish texts, although they reflect a process of addition, alteration, and probably omission, from the seventh century onwards.

<sup>15</sup> *Ibid.*, 77–8, 82. On the Pictish king-lists and *Lebor Bretnach*, see Thomas Owen Clancy, ‘Scotland, the “Nennian” recension of the *Historia Brittonum*, and the *Lebor Bretnach*’, in *Kings, clerics and chronicles in Scotland 500–1297. Essays in honour of Marjorie Ogilvie Anderson on the occasion of her ninetieth birthday*, ed. Simon Taylor (Dublin, 2000), 87–107, at 99–100.

<sup>16</sup> Dauvit Broun, *The Irish Identity of the Kingdom of the Scots in the Twelfth and Thirteenth Centuries* (Woodbridge, 1999), 144; Anderson, *Kings*, 77; Julia C. Crick, *The Historia Regum Britannie of Geoffrey of Monmouth*, vol.iii: *Summary Catalogue of the Manuscripts* (Cambridge, 1989), 256–61.

<sup>17</sup> Dauvit Broun, *Scottish Independence and the Idea of Britain: from the Picts to Alexander III* (Edinburgh, 2007), 75–8.

<sup>18</sup> Anderson, *Kings*, 85–8.

<sup>19</sup> See, for instance, the appearance in *Series breuior* twice of Óengus son of Fergus (Onuist son of Uurguist in Pictish) and Nectan son of Derelei.

<sup>20</sup> The date 834 is given as a *terminus post quem* since the use of the *-an/-en* suffix for the names Talorc/Talorgen and Drest/Drusten is the same in both *Series longior* and *Series breuior* up to the reign of Talorgen *filius* Uithoil (834–6/7). Since the common section of the lists ends soon after, in 842/3, the archetype could have been written in the reign of Cináed son of Alpín or soon after, but before the creation of the *Series longior* list.

<sup>21</sup> Miller, ‘The disputed historical horizon’, 3, 9.

There are clear indicators that the lists represented a Pictish over-kingship. Both versions begin with the king Cruithne son of Cinge, whose name, Cruithne, was actually the Gaelic term for Pict.<sup>22</sup> In the *Series longior* king-list, in an addition probably made 842/3x76, Cruithne is described as *pater Pictorum habitantium in hac insula*, ‘father of the Picts living in this island’, and is followed in the kingship by his seven sons, all of whose names, with the possible exception of *Foltlaig*, are those of Pictish territories.<sup>23</sup> Both these factors indicate that the *Series longior* list described the kingship of all the Picts. The other textual group, *Series breuior*, had a corresponding statement that Cruithne took the *monarchia* of the *regnum Pictorum* (found in MSS. D and F) or of the *terra Pictorum* (in MS. I), again indicating that a single kingship was being depicted.<sup>24</sup> Whichever version was the archetype’s, they all reflect the concept of a Pictish over-kingship, although it is possible that they were also considered to have been kings of Fortriu, the most prominent Pictish territory, for much of the early medieval period.

Most of the kings in the Pictish king-lists from the late sixth century to the late ninth century are found in the Irish chronicles. These annalistic chronicles survive in a number of manuscripts written in Ireland in the late eleventh century or later, but they contain a considerable body of mainly contemporary material concerned with northern Britain in the early medieval period.<sup>25</sup> The main chronicles providing evidence for northern Britain are the Annals of Ulster (written in the late fifteenth century), the Annals of Tigernach (written *c.*1350) and *Chronicum Scottorum* (written in the mid-seventeenth century).<sup>26</sup> The Annals of Tigernach and

---

<sup>22</sup> Anderson, *Kings*, 79.

<sup>23</sup> Broun, *Scottish Independence and the Idea of Britain*, 78–9, 93 n.47, where it is suggested that *Fidach* meant ‘woody’, perhaps being an artificial name. *Foltlaig* has been identified as a form of *Fotla*, a name for Ireland, indicating the territory of *Athfotla* (modern Atholl), ‘new Ireland’. If it is assumed that *Foltlaig* was *Fotla* (ignoring the problem of the *l* before the *t*, which is likely to have been part of the archetype), it is perhaps better to consider *Fotla* to mean simply ‘Ireland’ (or perhaps ‘Gaeldom’, implying all Gaelic areas), rather than Atholl, and a possible *Fotlaig* as the ‘people of *Fotla*’, comparable to the other territories which are rendered as population terms: *ibid.*, 93 n.47.

<sup>24</sup> Anderson, *Kings*, 265, 271, 279. Either reading could equally have been that of the *Series breuior* archetype.

<sup>25</sup> See Kathleen Hughes, *Early Christian Ireland: Introduction to the Sources* (London, 1972), 99–100, 105, 107–8.

<sup>26</sup> *The Annals of Ulster (to A.D. 1131)*, ed. Seán Mac Airt and Gearóid Mac Niocaill (Dublin, 1983) [hereafter AU]; ‘The Annals of Tigernach’, ed. Whitley Stokes, *Revue Celtique* 17 (1896), 6–33, 119–263, 337–420; *Revue Celtique* 18 (1897), 9–59, 150–97, 268–303 (repr. *The Annals of Tigernach*, 2 vols [Felinfach, 1993]) [hereafter AT]; *Chronicum Scottorum. A Chronicle of Irish Affairs from the Earliest Times to A.D. 1135, with a supplement containing the events from 1141 to 1150*, ed. and trans. William M. Hennessy (London, 1866) [hereafter CS]. The dates in these editions often contradict



*Chronicum Scottorum* share a common source written at some point from the first half of the twelfth century to c.1350, which, with the Annals of Ulster, was derived from a text which ended in 911, designated the ‘Chronicle of Ireland’ by modern scholars.<sup>27</sup> The ‘Chronicle of Ireland’ itself was based partly on a set of annals kept from the late sixth century to c.740 at the monastery of Iona.<sup>28</sup> After c.740 the record was maintained in Ireland, but some events in northern Britain were still recorded. The sources of this are uncertain but in the later eighth century information from Iona and somewhere in Pictland, as well as from Dunkeld in the late ninth century, may be responsible.<sup>29</sup> The Irish chronicles, therefore, often contain contemporary evidence for Pictish kings, albeit produced in the Gaelic-speaking areas of Scotland and Ireland.

Many of those included in the Pictish king-lists are also found in the Irish chronicles, some accompanied by the titles *rex Pictorum*, ‘king of the Picts’, or *rex Fortrenn*, ‘king of Fortriu’. It is possible that the chroniclers, in using these two terms, were making a distinction between over-kings of the Picts and those who ruled only Fortriu, but this is unlikely to be the case in most instances.<sup>30</sup> There is also potentially some ambiguity over whether *rex Pictorum* meant ‘a king of the Picts’, or ‘the king of the Picts’; in the Irish annals general population terms, such as *rex Saxonum* and *rex Britonum*, are used for kingdoms like those of Northumbria and of the Dumbarton Britons rather than over-kingships

---

each other, are not given for AT, and do not reflect real A.D. dates. A.D. dates can be calculated accurately from A.D. 664 onwards, but before then there is less certainty. For AT, since there is no editorial dating, A.D. dates will be given in square brackets for items from 664 onwards, but before then the number of annals from the start of the third fragment (marked as AT kl.) will be given. For other chronicles edition dates will be given preceded by the text’s abbreviation (for instance AU, CS). From 710 onwards the years in AU’s edition and the AT years given in brackets are in the correct A.D. year, but before 710 this is not the case, so before then A.D. dates will also be included (based on Nicholas Evans, *Recording and Re-interpreting History in Medieval Irish Chronicles: The Annals of Ulster, Annals of Tigernach and Chronicum Scottorum* [forthcoming]), using / for alternative years, or ? and c. where the exact year is uncertain.

<sup>27</sup> Kathryn Grabowski and David Dumville, *Chronicles and Annals of Mediaeval Ireland and Wales. The Clonmacnoise-group Texts* (Woodbridge, 1984), 175, 182–3. For the ‘Chronicle of Ireland’, see Hughes, *Early Christian Ireland*, 101–6.

<sup>28</sup> See John Bannerman, *Studies in the History of Dalriada* (Edinburgh, 1974), 9–26; Nicholas Evans, ‘Irish chronicles as sources for the history of northern Britain, A.D. 660–800’, *The Journal of Celtic Studies* 5 (2005), forthcoming.

<sup>29</sup> For the ‘Iona Chronicle’ see Bannerman, *Studies*, 9–26, and for the sources for events in northern Britain, see Evans, ‘Irish chronicles’. For the possibility of a Dunkeld source in the late ninth century, see Broun, *Scottish Independence and the Idea of Britain*, 84–6.

<sup>30</sup> See John Bannerman, ‘The Scottish takeover of Pictland and the relics of Columba’, in *Spes Scottorum: Hope of Scots. Saint Columba, Iona and Scotland*, ed. Dauvit Broun and Thomas Owen Clancy (Edinburgh, 1999), 71–94, at 75–83, for the view that *rex Fortrenn* in the annals meant that the person was king of southern Pictland, contrasting with *rex Pictorum*, used only for kings of all the Picts.

of the Anglo-Saxons and Britons.<sup>31</sup> However, when specific cases are studied, the evidence indicates that both *rex Fortrenn* and *rex Pictorum* were generally used in the Irish chronicles for Pictish over-kings.

The existence of an over-kingship is secured by statements made by Bede in his 'Ecclesiastical History of the English People'. Bede stated that the Pictish king Naiton (Nectan son of Derelei) distributed his Dionysiac Easter Tables 'throughout all the kingdoms of the Picts' (*per uniuersas Pictorum prouincias*), an event dateable to 710x16.<sup>32</sup> Since *prouincia* was used by Bede to mean 'kingdom', Bede's statement indicates that there were local kingships as well as the over-king in Pictland when Nectan's edict was enacted.<sup>33</sup> However, this may not necessarily have been the situation throughout the whole Pictish period.

Our understanding of Pictish political geography has recently been revolutionised by Alex Woolf's convincing argument that Fortriu was in fact in northern Pictland by the Moray Firth, rather than in southern Pictland, but the full implications of this have not yet been explored fully.<sup>34</sup> One consequence of Woolf's theory is that there is more evidence for rulers and dynasts being active in both Fortriu and southern Pictland or to the south of the Picts, although for most kings not enough events are recorded. Most evidence is found for kings Onuist son of Uurguist (729/32–61), Cinioid son of Uuredech (763–75), and Castantin son of Uurguist (c.788–820). Onuist was involved in a civil war in 728 and 729 which took place at least partially in southern Pictland (if Moncrieffe Hill, near Perth, was the site of the battle of Mónidhcroibh in 728, and if the battle of Monid Carno in 729 occurred near Tyndrum).<sup>35</sup> Onuist

<sup>31</sup> See Alex Woolf, 'Onuist son of Uurguist: *tyrannus carnifex* or a David for the Picts?' in *Æthelbald and Offa. Two Eighth-Century Kings of Mercia. Papers from a Conference held in Manchester in 2000*, BAR British Series 383, ed. David Hill and Margaret Worthington (Oxford, 2005), 35–42, at 35–6.

<sup>32</sup> *HE*, v.21, ed. Colgrave and Mynors, 552–3; for discussion see Kirby, '... *per uniuersas*', 292.

<sup>33</sup> Kirby, '... *per uniuersas*', 292. This structure, with kingdoms and an over-kingdom, is also indicated in *HE*, iii.4, ed. Colgrave and Mynors, 220–5, when Bede states that Columba taught the word of God to *prouinciae septentrionalium Pictorum*, 'to the kingdoms of the northern Picts', and that the whole kingdom (*prouincia*) was subject to the abbot of Iona.

<sup>34</sup> Alex Woolf, 'Dún Nechtain, Fortriu and the geography of the Picts', *SHR* 85 (2006), 182–201. One implication of the article, not explored here, is that, like Dún Nechtain, many other places may be located in northern Pictland. Such re-interpretations could modify the conclusions given here.

<sup>35</sup> AU 728.4 (AT [728].4), AU 729.2. For the identification of the place-names *Monidcroibh* and *Monid Carno*, see William J. Watson, *The History of the Celtic Place-names of Scotland* (Edinburgh and London, 1926), 400–2. In the light of Woolf's revision, it might be worth considering whether the battle of *Monid Carno* was located further north, near Loch Lochy close to Fort William, since Watson's rejection of this identification of *stagnum Loogde* in the Irish chronicle item (AU 729.2) was partly based

was in conflict with the Britons and Northumbrians in the 740s and 750s, according to the Continuation of Bede's Chronicle and Symeon of Durham's *Historia Regum*. He was called *rex Pictorum* in these sources, and the Irish chronicles at AU 736.1 (AT [736].1) and in AU 761.4 (AT [761].4).<sup>36</sup> According to AU 736.2, in the same period Onuist's brother, Talorgen son of Uurguist, led Fortriu against Dál Riata in battle, and in 750 died in battle against the Britons. Since Talorgen was campaigning in 736 in concert with Onuist, who was described as king of the Picts in the same annal, it is unlikely that he only led people from Fortriu. Together, these pieces of evidence indicate that Onuist controlled all of the Picts, at least for some of his reign.

Similarly, Ciniod son of Uuredech (763–75) is likely to be both the *Cináed* who fought an Áed in Fortriu according to AU 768.7 and the *Cynocht* to whom the exiled Northumbrian king Ahlfred fled from Bamburgh in 774, an action which indicates that Ciniod ruled southern Pictland, which bordered on Northumbria.<sup>37</sup> He is described as *rex Pictorum* in the Irish annals (in AU 775.1 and the *Annals of Roscrea* §\*205.3), in AC *s.a.* 776, and in *Symeon of Durham s.a.* 774 and 775, so in this case *rex Pictorum* is likely to denote the whole of Pictland.<sup>38</sup> The other king, Castantin son of Uurguist (*c.*788–820), is described as *rex Fortrenn* in the Irish chronicles, but he was also very likely to have been the person commemorated on the ninth-century Dupplin Cross just

---

on the view that the civil war of 728–9 took place in Perthshire. Adomnán's *stagnum Lochdae* (*Vita Sanctae Columbae* [hereafter Adomnán, *VC*], i.34, ed. and trans. Alan Orr Anderson and Marjorie Ogilvie Anderson, *Adomnán's Life of Columba*, rev. edn [Oxford, 1991], 10–11) was identified by Watson (*Celtic Place-names*, 401) as the loch near Fort William, so this may have been the most obvious location to the Iona annalist who included this item in the chronicle.

<sup>36</sup> For campaigns involving Onuist and his brother Talorgen against the Britons and Northumbrians, see AU 750.4 (AT [750].4), AC 750; *s.a.* 750 of the *Continuatio Bedae*, ed. and trans. Bertram Colgrave and R. A. B. Mynors, *Bede's Ecclesiastical History of the English People* (Oxford, 1969; repr. with corrections 1991), 572–7 [hereafter *Continuatio Bedae*], at 574–5, and *s.a.* 744 and *s.a.* 756 of Symeon of Durham's *Historia Regum*, ed. T. Arnold, *Symeonis Monachi Opera Omnia*, Rolls Series, 2 vols (London, 1882–5) [hereafter *Historia Regum*], 38, 40. See Katherine Forsyth (with an appendix by John T. Koch), 'Evidence of a lost Pictish source in the *Historia Regum Anglorum* of Symeon of Durham', in *Kings, clerics and chronicles*, ed. Taylor, 19–34, for further discussion of the latter two sources' Pictish items, and Woolf, 'Onuist son of Uurguist', 37–9. For the obits of Onuist, see AU 761.4, AT [761].4, *Continuatio Bedae*, *s.a.* 761, and the *Historia Regum*, *s.a.* 759.

<sup>37</sup> *Historia Regum*, *s.a.* 774.

<sup>38</sup> *The Annals of Roscrea*, ed. D. F. Gleeson and S. Mac Airt, 'The Annals of Roscrea', *Proceedings of the Royal Irish Academy* 59C (1957–9), 137–80 [hereafter ARC], may be a compilation of different chronicles, but it is very likely that at least one of these was an early version of the Clonmacnoise group of chronicles.

north of the river Earn in southern Pictland.<sup>39</sup> In conjunction the evidence supports the view that Castantin, like Onuist son of Uurguist and Ciniod son of Uuredech, who ruled for much of the period from 732 to 820, controlled both Fortriu and southern Pictland.

Two items in the Irish chronicles provide more evidence for the geographical extent of the terms *rex Fortrenn* and *rex Pictorum*. In AU 866.1 it is stated that the Scandinavians Amlaib and Auisle went to Fortriu with the foreigners of Ireland and Alba, plundered all of *Cruithentuath*, the ‘Pictish country’, and took away hostages from them.<sup>40</sup> In this item Fortriu is clearly considered to be synonymous with Pictland, which supports the view that by this time *rex Fortrenn* could be used interchangeably with *rex Pictorum* for the over-kingship of the Picts. Further evidence can be found in the appearance in AU 782.1 of the title *rex Pictorum citra Monoth*, ‘king of the Picts this side of the Mounth’ in the obituary notice for a certain Dub Tholargg. Such a description, which is very unusual for the Irish annals, probably was only used because Dub Tholargg’s rule did not correspond with a previous political division. It is unlikely that his title refers to Fortriu, which had been mentioned in the annals from the late seventh century onwards. Instead, it probably describes the area of Pictland south of the Mounth (the Grampian mountains in eastern Scotland dividing Angus and the Mearns from Buchan, Mar and Moray), but the area west of the Highlands is another potential possibility.<sup>41</sup> It is significant because it also indicates that *rex Pictorum* was perceived to be too unspecific a designation for a king of only some of the Picts, which implies that *rex Pictorum* was reserved for over-kings (by that particular writer at least).

Overall then, when Bede’s evidence for an over-kingship is combined with that of the Pictish king-lists and the Irish annals, the most plausible inference is that after Bredei son of Bile, king of Fortriu, defeated Ecgfrith, king of Northumbria, in 685 at the battle of Dún Nechtain, those described in the Irish chronicles as *rex Fortrenn* or *rex Pictorum* were generally over-kings of the Picts. However, before the late seventh century there is less evidence, and it is uncertain whether the annalistic and king-list evidence is contemporary: the Irish chronicle record is virtually confined to obituary notices with some people being

---

<sup>39</sup> AU 820.3; Katherine Forsyth, ‘The inscription on the Dupplin Cross’, in *From the Isles of the North. Early Medieval Art in Ireland and Britain*, ed. Cormac Bourke (Belfast, 1995), 237–44.

<sup>40</sup> AU 866.1: *Amlaiph 7 Auisle do dul i Fortrenn co nGallaib Erenn 7 Alban cor innriset Cruithentuath n-uile 7 co tucsat a ngiallo.*

<sup>41</sup> See Watson, *Celtic Place-Names*, 391–407, for the use of *monadh*. The lack of any specifying element in AU 782.1 means that it was clear what *monadh* was being referred to by the writer of the chronicle item at least, and perhaps by his audience as well, rendering it likely that it was a major landscape feature.

given (perhaps retrospectively) the title *rex Pictorum*, and the Pictish king-lists before the 660s could have been substantially altered at a later date.<sup>42</sup> Generally both sources contain the same kings in the late sixth and seventh centuries (with a few differences which indicate that they were independent of each other), so they are both likely to be recording the same kingship.<sup>43</sup>

The extent of this kingship is difficult to define exactly. The fact that both Bredei son of Mailcon (556/7–86/7) and Bredei son of Bile (671–92) had their political bases in the north, in Fortriu, renders it likely that they were either mainly kings of Fortriu, or over-kings of the Picts.<sup>44</sup> However, the appearance of Cindaelath (probably the Galam Cennaleph of the Pictish king-lists) as a king in the Irish annals who presumably ruled elsewhere at the same time as Bredei son of Mailcon, indicates that not all the kings in the Irish chronicles and Pictish king-lists were necessarily rulers of Fortriu.<sup>45</sup> It is possible then that the Pictish over-kings in the sources were sometimes drawn from different Pictish polities.

There are plenty of indications that there were indeed regional kingships in Pictland other than Fortriu. Bede provides evidence for kingdoms ruled by an over-king, and with the *Annals of Ulster* in 782, indicates that the Mounth and the mountains in general could have facilitated political divisions.<sup>46</sup> In addition, Adomnán in his ‘Life of St Columba’ mentioned that a sub-king of Orkney was in the power of the sixth-century king Bredei son of Mailcon, which could either reflect the reality of Columba’s time in the late sixth century, or of Adomnán’s

---

<sup>42</sup> *Rex Pictorum* is found before 660 in AU 580.3, AT kl. 87.2 (=A.D. 582/3); AU 584.3 (=A.D. 586/7); AT kl. 105.2 (=A.D. 600/1/2); AU 631, AT kl. 135.2, CS 631 (=A.D. 632/3); AU 653.1, AT kl. 154.2 (=A.D. 653?); AU 657.3 (=A.D. 656?).

<sup>43</sup> An indication that the Irish chronicles and the Pictish king-lists are independent of each other is the fact that the Pictish king-lists have the reign of Galam Cennaleph before Bredei son of Mailcon, whereas the Irish annals have them reigning contemporaneously, with a Cindaelath dying in A.D. 582/3 (AU 580.3, AT kl. 87.2), before Bredei’s obit in AU 584.3 (=A.D. 586/7) and AT kl. 90.1 (=A.D. 585/6), but after an item recording the flight before a ‘son of Mailcon’ in AU 558.2 (=A.D. 561/2?), and AU 560.2, CS 560.3, AT kl. 67.3 (=A.D. 563/4?).

<sup>44</sup> Woolf, ‘Dún Nechtain’, 196–7, 201. The evidence that Bredei son of Mailcon was based around Loch Ness, and that he had a sub-king in the Orkneys can be found in Adomnán’s *Life of St Columba*: Anderson, *Kings*, 144.

<sup>45</sup> It is possible that Galam Cennaleph (Cindaelath) was a king among the southern Picts if they were the same person. Another king potentially based among the southern Picts is Nectan *nepos* Uerp, if he was involved in the foundation of Abernethy on the southern side of the Tay estuary, although it is also possible that he was a northern Pictish king granting lands in the south (perhaps previously owned by southern rivals) to bolster his support there. James Fraser has suggested to me that some of the kings before Bredei son of Mailcon in the Pictish king-lists may have been included from a list of kings of the southern Picts. This is possible because of the realistic reign-lengths (and perhaps also names) given for most fifth- and sixth-century kings after Drest son of Uerp.

<sup>46</sup> *HE*, iii.4, ed. Colgrave and Mynors, 220–5.

in the late seventh and early eighth centuries.<sup>47</sup> The Irish chronicles also record the killing by the Pictish king Onuist son of Uurguist of Talorgen son of Drusten, described as *rex Athfoitle* (AU 739.7).<sup>48</sup> This title is ‘king of Atholl’, which means ‘New Ireland’, presumably at least part of the highland area between lowland southern Pictland and Dál Riata in the west.<sup>49</sup>

Another local group mentioned by Adomnán (in a conflict with Dál Riata) is the Miathi, probably the same group as the Maeatae, placed next to the Antonine Wall south of the Caledonii by Cassius Dio in the early third century A.D.<sup>50</sup> Since this battle was located in the Pictish region of Circenn in the *Annals of Tigernach*, the Miathi were probably also active further north than the two places near Stirling, Dumyat and Myot Hill, which bear their name, especially if Circenn included Strathearn.<sup>51</sup> It is not clear when the Miathi ceased to be a separate political entity, although this was presumably before the battle of Dún Nechtain in 685 at the latest. It is possible that some of the kings in the Pictish king-lists and Irish annals were rulers of the Miathi, but there is no clear evidence either way. Indeed, it is salutary to note that Northumbrian dominance of southern Pictland, which lasted from some point in the reign of King Oswiu (642–70) to 685, is not detectable in the Pictish king-lists or the Irish chronicles.<sup>52</sup> The most plausible explanation of this is that during this period the recorded Pictish kings were of Fortriu or northern Pictland, rather than of all the Picts. This indicates that the evidence we have could

<sup>47</sup> Adomnán, *VC*, ii. 42, ed. Anderson, 166–7.

<sup>48</sup> The title is *rex Athfhotla* in AT [739].6.

<sup>49</sup> This area’s name, and the evidence of dedications to Ionan abbots of the late seventh and early eighth centuries (see Dauvit Broun, ‘The seven kingdoms in *De situ Albanie*: a record of Pictish political geography or imaginary map of ancient *Alba*?’ in *Alba. Celtic Scotland in the Medieval Era*, ed. Edward J. Cowan and R. Andrew McDonald [East Linton, 2000], 24–42, at 28–9, 31, 33–6; Simon Taylor, ‘Seventh-century Iona abbots in Scottish place-names’, in *Spes Scotorum*, ed. Broun and Clancy, 35–70, at 39–43, 52–5, 58–60, 68–9) indicate that the area could have been Gaelicised by this time, although the name Talorgen son of Drusten is Pictish.

<sup>50</sup> Adomnán, *VC*, i.8, i.9, ed. Anderson, 30–3; see Anderson, *Kings*, 124–5. The Maeatae are described by Dio Cassius as dwelling near the Antonine Wall, in mountains and marshy plains, with the Caledonii beyond them: Watson, *Celtic Place-names*, 56–7. It is not certain whether the Miathi should be regarded as Picts, although it is likely that they should be considered to have shared in some respects a common culture with those immediately to the north of them.

<sup>51</sup> Watson, *Celtic Place-names*, 56–9, 108–10. The battle mentioned by Adomnán is probably the same one which AT kl. 103.2 (=A.D. 598?) describes as *cath Chirchind*. Since Fortriu is probably in northern Pictland, Circenn could have included areas formerly considered to have been Fortriu, including Strathearn: Broun, ‘The seven kingdoms in *De situ Albanie*’, 40–1.

<sup>52</sup> Unless the reign-length given to Ecgrith (king of Northumbria 670–85) in AU 686.1, AT [685].4 (=A.D. 685) referred to his dominance over the Picts.

reflect the theoretical claims of kings to the whole of Pictland in the seventh century or later, rather than political reality.

Taking everything together then, it becomes clear that it is only possible to study in detail the succession of one, rather than all, of the Pictish kingships. For most of the period from the late seventh century to the end of the ninth century this identifiable succession was for the over-kingship of the Picts, dominated by kings of Fortriu. However, before the reign of Bredei son of Bile the situation is less clear; the kingship(s) found in the Irish chronicles and the Pictish king-lists could be of all the Picts, of Fortriu, or the combined records of kings of different areas, although a perceived over-kingship, increasingly dominated by Fortriu, is most likely. Given the evidence for multiple Pictish kingships, the succession patterns found in our sources do not necessarily provide a typical case-study; other areas of Europe display considerable variety in practice, depending on specific social, political, and dynastic considerations, so we probably should not imagine that only a single succession system existed among the Picts.<sup>53</sup>

#### *Pictish succession before 730 in the king-lists and Irish chronicles*

When we can consider the evidence for this over-kingship in the Pictish king-lists and Irish chronicles, some basic aspects of the succession from Galam Cennaleph in the late sixth century to Castantín son of Cináed (862–76) emerge. Table 1 lists the names of kings in this section. Those names found for kings earlier in the list, described as ‘royal names’, are placed in bold, names not in bold are those not used before for kings, and kings with names previously used only for a father of a king are put in italics.<sup>54</sup>

As has often been noted, one basic feature is that before the late eighth century there is no instance of a son becoming king after his father. This can be inferred from the fact that the names of kings’ fathers do not correspond to those of preceding kings.<sup>55</sup> From Ciniod son of Uuredech

<sup>53</sup> Ian Wood, ‘Kings, kingdoms and consent’, in *Early Medieval Kingship*, ed. P. H. Sawyer and I. N. Wood (Leeds, 1977), 6–29.

<sup>54</sup> The dates are based on the evidence of the Irish chronicles and the Pictish king-lists. After Ciniod son of Lutrín, the uncertainty is usually over the exact dates of the reign, rather than the existence or length of the reign itself. I have not included in this list extra SB kings, including the three kings (using SB I’s readings) *Kineth filius Ferech*, *Brude filius Fokel*, and *Drest filius Ferech* at the end of the list, since these could be later additions. Before Bredei son of Derelei only Pictish kings found in both SL and SB are included in the study. After Bredei son of Derelei there are numerous errors in SB, so kings only found in SL are included in the study. *f.* stands for *filius*, ‘son’.

<sup>55</sup> Anderson, *Kings*, 166. One potential reason for this could be that mothers’ rather than fathers’ names are sometimes given, as is probably the case for Nectan son of Derelei: T. O. Clancy, ‘Philosopher-king: Nechtan mac Der-Ilei’, *SHR* 83 (2004), 125–49, at 127–9, 147–8. However, in the section before 730 the names Lutrín (my thanks go to

Table 1: Pictish kings from the late sixth century to the late ninth century (following *Series longior*).

Galam Cennaleph (579?–82?) <sup>a</sup>	<b>Bredei</b> <i>f.</i> Uurguist (761–3)
<b>Bredei</b> <i>f.</i> Mailcon (556/7–86/7)	<b>Ciniod</b> <i>f.</i> <b>Uuredech</b> (763–75)
<b>Gartnait</b> <i>f.</i> Domech (586/7–600/1/2)	<b>Elpin</b> <i>f.</i> Uuroid (775–8/780?) <sup>b</sup>
<b>Nectan nepos</b> Uerb (600/1/2–13/14/18/19?)	<b>Drest</b> <i>f.</i> <b>Talorgen</b> (778–9?)
Ciniod <i>f.</i> Lutrin (613/14/18/19?–32/3) <sup>c</sup>	<b>Talorgen</b> <i>f.</i> <b>Drusten</b> (780–4, 782–4?)
<b>Gartnait</b> <i>f.</i> Uuid (632/3–6/7)	<b>Talorgen</b> <i>f.</i> <b>Onuist</b> (779–82?)
<b>Bredei</b> <i>f.</i> Uuid (636/7–42?)	Canaul <i>f.</i> Tarl'a (784–c.88?)
<b>Talorc</b> <i>f.</i> Uuid (642?–53?)	Castantin <i>f.</i> Uurguist (c.788?–820)
<b>Talorgen</b> <i>f.</i> Enfret (653?–6?)	<b>Unuist</b> <i>f.</i> Uurguist (820–34)
<b>Gartnait</b> <i>f.</i> Donuel (656?–63?)	<b>Drest</b> <i>f.</i> <b>Castantin</b> , and <b>Talorgen</b>
<b>Drest</b> <i>f.</i> Donuel (663?–71)	<i>f.</i> Uithoil (834–6/7)
<b>Bredei</b> <i>f.</i> Bile (671–92)	Uuen <i>f.</i> <b>Unuist</b> (836/7–9)
<b>Taran</b> <i>f.</i> Entifidich (692–6)	<i>Uurad</i> <i>f.</i> Bargoit (839–41/2)
<b>Bredei</b> <i>f.</i> Derelei (696–707)	<b>Bred</b> (841/2–2/3)
<b>Nectan</b> <i>f.</i> Derelei (707–24, 729–32)	<b>Cinaed</b> <i>f.</i> <b>Alpin</b> (842/3–58)
<b>Drest</b> (724–6) and Elpin (726–9)	Domnall <i>f.</i> <b>Alpin</b> (858–62)
Onuist <i>f.</i> Uurguist (729/32–61)	<b>Castantin</b> <i>f.</i> <b>Cinaeda</b> (862–76)

<sup>a</sup> The name Galam may occur earlier in the Pictish king-list; there is a king whose name is spelt *Galaman Erilich* (SL1), *Galan Arilith* (SL20), but also as *Galam* (SB F) or *Galany* (SB I). The form most likely to have been present in the common source of all the lists is *Galan*, but since it was common to render a nasal sound with an abbreviation stroke, the original could have been *Galam*, or *Galam Cennaleph* should originally have had *Galan*.

<sup>b</sup> The succession of kings in the late 770s and 780s is difficult to reconstruct. The dates given are based on a theory that the Pictish king-lists reflect a division of the kingship in this period, with the following sequences of kings: one for an area which was probably southern Pictland, with Elpin son of Uuroid (775–8 deposed), Drest son of Talorgen (778–9), Talorgen son of Onuist (779–82), Talorgen son of Drusten (782–4); and the other area perhaps in northern Pictland, with Elpin son of Uuroid (775–80), Talorgen son of Drusten (780–4). I intend to discuss this highly tentative reconstruction in more detail at a later date.

<sup>c</sup> There is a *Cinioiod filius Ar(t)cois* earlier in the list only in SL manuscripts, but this name is likely to have been an addition made 842×76.

(763–75) onwards, however, the names of the fathers are usually the same as those for earlier kings. Given that often these are the names of kings who reigned in the previous generation or so, and that names such as Onuist and Uurguist recur, it has reasonably been proposed by

---

John Koch and Graham Isaac for confirming that Jackson viewed this as masculine), Mailcon, Uuid, Enfret and Bile are male: see H. M. Chadwick, *Early Scotland. The Picts, the Scots and the Welsh of Southern Scotland* (Cambridge, 1949), 15; K. H. Jackson, 'The Pictish language', in *The Problem of the Picts*, ed. F. T. Wainwright (Edinburgh, 1955), 162, 163–4; Anderson, *Kings*, 167, 248 n.105. Uerp and the earlier Muirthoiloic and Arcois (only found in SL) are also probably male: Chadwick, *Early Scotland*, 13; Jackson, 'The Pictish language', 137, 165; Anderson, *Kings*, 246 n.82. After 730 virtually all of the names are identifiably male. Most are found elsewhere in Celtic languages (see Jackson, 'The Pictish Language', 144–5, 161–6), the exceptions being Bredei, Uithoil and Bargoit. On balance then, given our limited corpus of Pictish names whose gender can be determined, most of the names not found elsewhere are likely to have been male,



Dauvit Broun that many of the kings from Onuist son of Uurguist (729/32–61) to 839 were part of a single dynasty related to Onuist.<sup>56</sup>

Another significant feature is that there are cases of brothers immediately succeeding each other, for instance the successions of the sons of Uuid, Donuel and Derelei in the seventh century, even in the periods where sons did not succeed their fathers. The succession of brothers was common in other early medieval societies, such as Anglo-Saxon England, although this was usually combined with father-to-son succession.<sup>57</sup> The succession of brothers also supports Bede's evidence that familial relationships were significant in determining the selection of the Pictish kings represented in the lists.

As well as this there are two instances of joint reigns in this section of the king-list. One of these, the joint-reign of Drest and Elpin (724–9), may be a rationalisation of a more complex situation, since the Irish chronicles indicate that Drest and Elpin reigned consecutively; AT [724].2 states that Drest began to reign after the previous king, Nectan, became a cleric, then AT [726].4 describes the deposition of Drest, and his replacement with Elpin. However, both were active in the civil war of 728–9, and it is probable that it was either Elpin or Nectan who bound the son of Drest in 725.<sup>58</sup> The exact political situation may have varied from 724 to 729, but it seems unlikely that Elpin and Drest were ruling co-operatively for much of this time. The king-list, therefore, may be hiding a division of the kingship or the active opposition of Drest and Elpin when the other was dominant. The situation in the other example, the joint-reign of Drest son of Castantin and Talorgen son of Uithoil (probably from 834 to 836/7), is much more obscure, since we have no evidence for it other than the Pictish king-list. Drest is likely to have

---

but it cannot be ruled out that a few, like Derelei, were female. It is unlikely, then, that the assumption that the list has patronymics is incorrect, although occasional matronymics do not damage the general argument presented in this article. The reduction after 730 in names unattested elsewhere is noticeable, but it is unclear whether it was merely a function of a different succession pattern, or whether it represents a significant change in nomenclature in its own right (such as a growing preference for linguistically Celtic, especially Brittonic, names).

<sup>56</sup> Dauvit Broun, 'Pictish kings 761–839: Integration with Dál Riata or separate development?', in *The St Andrews Sarcophagus. A Pictish Masterpiece and its International Connections*, ed. Sally M. Foster (Dublin, 1998), 71–83, at 73–5, 81–2. However, Broun's view that Drest son of Talorgen was the son of Talorgen son of Onuist is questionable, since Drest reigned before Talorgen son of Onuist, according to the Pictish king-lists. Perhaps Drest son of Talorgen was the son of Talorgen son of Uurguist (brother of kings Onuist (729/32–61), and Bredei (761–3) who died in 750 (AU 750.4, AT [750].5), or was the son of Talorgen son of Drusten, king of Atholl (his killing is recorded in AU 739.7, AT [739].7).

<sup>57</sup> See above, 3–5.

<sup>58</sup> AT [725].3, AU 725.3; Anderson, *Kings*, 177–8.

been the son of Castantin son of Uurguist (c.788–820), so the division could possibly reflect some unwillingness to accept the son of a former ruler as king.<sup>59</sup> The appearance of this joint-reign at least indicates that there was some degree of flexibility in the actual role of the kingship. Such joint-reigns are known elsewhere in Europe: they occurred among the Anglo-Saxon kingdoms of Northumbria, Kent, the East Saxons and West Saxons, as well as among the Irish, Merovingian Franks and the Burgundians, although what this actually entailed in terms of relative powers and jurisdictions varied in practice.<sup>60</sup>

The general pattern of succession to the Pictish kingship is not on initial inspection abnormal for the early medieval period: elsewhere brothers often succeeded each other, and there were joint reigns. What seems strikingly different from the Anglo-Saxon kingships known to Bede is the lack of father-to-son succession before 731, but, as Alex Woolf has demonstrated studying Anglo-Saxon and Gaelic kingships, there were periods when sons were unable to follow their fathers in many kingships, so such a practice may only have seemed unusual to Bede if he recognised that it had continued over a long period.<sup>61</sup> Changes in the Pictish succession pattern are also paralleled by the fluidity of other kingships, whose practices could change quite significantly as a result of altered political situations.<sup>62</sup>

However, while many aspects of the Pictish succession pattern are found elsewhere, the Pictish over-kingship seems to have been unique in one respect: that before the mid-eighth century the names of kings are completely different to those of their fathers (see Table 1). The most satisfactory explanation for this is that there were royal names, such as Bredei, Drest, Nectan, Talorgen and Gartnait, used for kings, but not for their fathers. The exceptions may be Galam Cennaleph and Ciniod son of Lutrín whose names were not necessarily found as royal names in the prehistoric section of the king-lists. Supporting evidence for regal nomenclature, albeit in a later, Irish, context, is found in a text in Middle Irish, *Aided Dhiarmada*, in which sovereignty is characterised as being

---

<sup>59</sup> M. O. Anderson, 'Dalriada and the creation of the kingdom of the Scots', in *Ireland in Early Mediaeval Europe*, ed. Whitelock, McKitterick and Dumville, 106–32, at 111.

<sup>60</sup> Wood, 'Kings, kingdoms', 17–23; Yorke, *Kings and Kingdoms*, 32–4 for Kent, 52–3 for the East Saxons, 69 for the East Angles, 75, 78–9 for seventh-century Northumbria, 133–4, 143–5 for Wessex, 170; Francis J. Byrne, *Irish Kings and High-Kings*, 2nd edn (Dublin, 2001), 36, 119, 161, 250, 264, for examples from Ireland of the *lethri*, 'joint-king' (literally 'half-king').

<sup>61</sup> Woolf, 'Pictish matriline reconsidered', 154–8. It is possible that the lack of father-to-son succession among the Picts would have been somewhat obscured by the succession of brothers.

<sup>62</sup> Wood, 'Kings, kingdoms', 9, 14, 25–6.

‘From Niall to Niall. From Bruide to Bruide’.<sup>63</sup> This indicates that in Ireland the name Bruide (Bredei) was closely associated with kingship (even though it is only attested among the Picts) and could be paralleled with Niall of the Nine Hostages, the ancestral figure of the powerful Uí Néill dynasty which dominated much of Ireland, and claimed the kingships of Tara and Ireland. The existence of preferred names for members of the royal dynasty is not unknown elsewhere in the early medieval period, being found for members of the Merovingian dynasty which ruled the Franks from the time of Clovis (d.511) to 751.<sup>64</sup> There was also a tendency for Anglo-Saxon dynasties to prefer names beginning with the same vowel or consonant.<sup>65</sup> However, the practice of distinguishing between kings and their fathers’ names is much more unusual.

This pattern could be explained away by arguing that people changed their names on becoming king to a royal name.<sup>66</sup> However, in the cases we do have of close relatives of Pictish kings (such as brothers and sons), their names are royal: the brother of kings Bredei and Nectan, sons of Derelei, was called Ciniod in his obituary notice in AU 713.4; and the son and brother of Onuist son of Uurguist (729/32–61), both of whom pre-deceased him, were called Bredei and Talorgen respectively.<sup>67</sup> Since

---

<sup>63</sup> Edel Bhreathnach, ‘*Níell cáich úa Néill nasctar géill: the political context of Baile Chuinn Chétchathaig*’, in *The Kingship and Landscape of Tara*, ed. Edel Bhreathnach (Dublin, 2005), 67.

<sup>64</sup> See Ian Wood, *The Merovingian Kingdoms, 450–751* (London, 1994), 343–9, for a genealogy of the Merovingian dynasty.

<sup>65</sup> For Anglo-Saxon examples, see the genealogies for Kent and the West Saxons in Woolf, ‘Pictish matriline reconsidered’, 167, and for the kings of the East Saxons in Yorke, *Kings and Kingdoms*, 52. Another, later, example of highly restricted royal nomenclature is the royal family in the UK.

<sup>66</sup> For the example of Daniel, who adopted the Merovingian name of Chilperic on his accession in 715, see Wood, *Merovingian Kingdoms*, 267–9. Another, twelfth-century, example (kindly drawn to my attention by David Sellar) is the instance in *Orkneyinga Saga*, ch.61, trans. Hermann Pálsson and Paul Edwards, *Orkneyinga Saga. The History of the Earls of Orkney* (London, 1977), 106, in which King Sigurd of Norway gave Kali Kolsson (d.1158) half of Orkney (which his uncle, St Magnus, had also owned), the title of earl, and the name Rognvald, because Kali’s mother claimed that an earlier earl of Orkney, Rognvald Brusason, had been very able.

<sup>67</sup> Bredei son of Onuist is mentioned in AU 731.6 (AT [731].5), AU 733.1, AU 736.1 (AT [736].1), and Talorgen son of Uurguist in AU 736.2, AU 750.4 (AT [750].4). The case of the relatives of Onuist should perhaps not count, since he possibly should never have been king (see 45–7 below), although this itself is based on an inference from the name pattern. In addition to these examples, a *Talorgg filius Drostain* is described as brother of King Nectan, presumably the over-king Nectan son of Derelei, in AU 713.7. However, since he was probably the Talorgen son of Drusten described in AU 739.7 (AT [739].6) as king of Atholl on his death, his case may have been different to others who were only candidates for the over-kingship or the kingship of Fortriu. For studies of their familial relationship, see Clancy, ‘Philosopher-king’, 133–6; Anderson, *Kings*, 175–6.

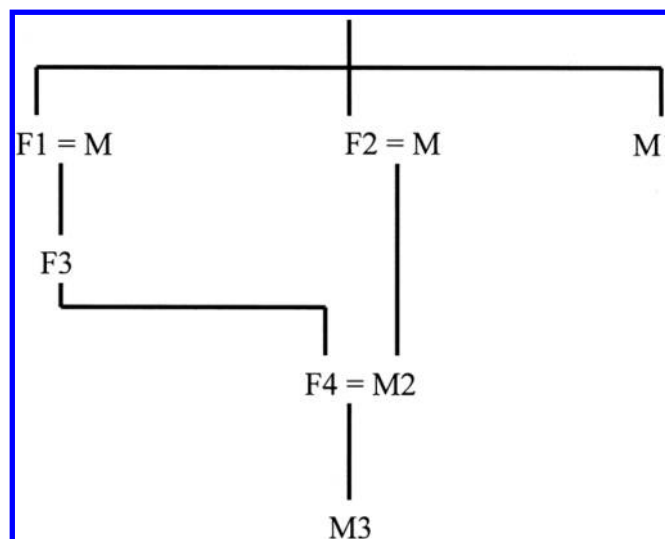

Fig. 1: Possible father-to-son succession in a matrilineal system.

none of these people became king, they show that royal names were not assumed on someone's accession to the kingship.<sup>68</sup>

It would seem, therefore, that not only did the Pictish kings represented in the king-list already have royal names, but (up to the mid-eighth century) their fathers also had to have non-royal names. This is usually used as evidence for matriliney, since under such a system, instead of sons succeeding their fathers, the son of the king's sister would normally become the next king rather than the sons of previous kings.<sup>69</sup> However, matriliney does not completely explain the phenomenon, since a king could marry a royal female and therefore produce a son who could become king (see Fig. 1). In this hypothetical case, the first king (M1) is succeeded by the son (M2) of his sister (F2). M2 marries F4, the granddaughter of F1 (M2's mother's sister), and has a son, M3.<sup>70</sup> If M2 does not have any sisters, then under a matrilineal system the succession would probably have gone back through F1's line via F3 and F4 to M3, with the result that M2's son would be king. Such a scenario would only need to involve perhaps one unusual event – that F2 does not have a daughter – for it to take place. It should be recognised that the

<sup>68</sup> They are described as kings in AC 736 and 750, but this could be an alteration from the Irish chronicle used as a source for *Annales Cambriae* in the tenth century. For the use of an Irish chronicle, see Grabowski and Dumville, *Chronicles and Annals*, 209–26, esp. 225–6.

<sup>69</sup> For instance, see Anderson, *Kings*, 166. Often though the king-lists are used as evidence against patriliney: Wainwright, 'The Picts', 25.

<sup>70</sup> See n.119 below, on cousin marriage.

simple matrilineal relationships presented in some scholarship, whereby the sister's sons of kings tend to succeed, are unlikely to represent the complexity of the situation if the succession were actually matrilineal.<sup>71</sup>

The straightforward sister's son succession would require first that the king's mother had both a son and a daughter (who reaches child-bearing age), and secondly that the sister has a son. The matrilineal system is, therefore, more likely to lead to the succession passing to another branch of the royal dynasty than a patrilineal system. This increases the chances of the scenario envisaged above, of father-to-son succession, taking place. It might also be in a king's interest to marry an eligible female member of the dynasty not only to ensure that his branch of the family could regain the kingship in later generations, but also to reduce the number of potential rivals from other branches of the dynasty. Given all these factors, it might be expected that a son of a previous king would have succeeded to the Pictish kingship at some point in the period from the late sixth century to the mid-eighth century. Since this was not the case, it is likely, as Molly Miller proposed, that there was a prohibition on a king marrying a woman whose son would be a potential king, although a similar result would come from the exclusion from the kingship of the son of such a marriage.<sup>72</sup> This indicates that the prohibition on father-to-son succession was more important than matrilineality or patrilineality.

It could be argued that the lack of sons succeeding their fathers in the kingship in the period from the late sixth to the mid-eighth century was just chance, due to people taking power by force. Certainly, it is true that in the section of the Irish chronicles where we are given the most evidence regarding the end of Pictish kings' reigns and the succession of new rulers, from about 670 to 740, there are references to the use of force: Pictish kings were deposed in 671, 696, perhaps 724, 726, and in 728–9.<sup>73</sup> All but two or three of the successions from 670 to 730

---

<sup>71</sup> For a pertinent warning against simplified genealogical models and the 'invention' of too many people to create a royal dynasty, see also Ross, 'Pictish matrilineity?', 12–14. However, the lack of evidence, particularly for women, does mean that hypothesising the existence of many unrecorded people is probably necessary, but the possible permutations are too numerous for a family tree to be reconstructed before the late eighth century, when the name pattern changes.

<sup>72</sup> Miller, 'The last century', 54.

<sup>73</sup> See AU 672.6, AT [671].5 (=A.D. 671); AU 697.1, AT [696].1 (=A.D. 696); AT [724].2; AT [726].4. King Elpin was defeated twice in battle by Onuist son of Uurguist in 728 (AU 728.4, AT [728].4 and AT [728].5), which probably marked the end of his reign. In the following year AU 729.3 records that Drest, king of the Picts (probably the king deposed in 726 by Elpin) was defeated by Onuist at Druim Derg Blathuug, which makes it possible that Drest had briefly regained his kingship. The equivalent item in AT, AT [729].4 has *eter Piccardaib .i. Drust 7 Aengus .r. na Piccardach*, which is probably a re-ordering of AU's *inter Oengus 7 Drust regem Pictorum*.

(the exceptions being Bredei son of Bile, Bredei son of Derelei, and perhaps Nectan son of Derelei), therefore, were decided by force.<sup>74</sup> In two of the cases of expulsion, in 671 and 696, the name-pattern for Pictish kings and their fathers was still adhered to, although the expulsions of Drest and Elpin in the 720s provide uncertain evidence, since their patronymics are unknown. Onuist son of Uurguist's name breaks the nomenclature pattern, and Elpin is not a name found for earlier Pictish kings, but this could reflect the beginning of the breakdown of the name system rather than a continuation of earlier practice.<sup>75</sup> This evidence, then, is not decisive, but given that the section of the Irish chronicles from 660 to 740 contains the most detailed account of events among the Picts, and the king-lists do not mention depositions, and that there were two more depositions in the late eighth century, it is plausible that some of the kings before 660, where we do not have similar evidence, also succeeded by force.<sup>76</sup> If force were the only issue, then the name-pattern would surely have been broken at some point. The adherence to the name pattern of the fifteen kings from Galam Cennaleph (d.582/3?) to Nectan son of Derelei (who was deposed in 724), even when force was involved, indicates that a person's name was an important factor determining the selection of those who could challenge for the kingship; people could not be considered as candidates unless they had a royal name, like Bredei or Talorgen, and their father possessed a non-royal name. The most plausible conclusion is that most of those who ruled after a coup were able to become king because they already had some legitimacy under the pre-

---

<sup>74</sup> AU 693.1, AT [692].2 (=A.D. 692); AU 706.2, AT [707].2 (=A.D. 707); AT [724].2. In the case of Bredei son of Derelei, it is also possible that his mother, Derelei, was the source of his legitimacy (Clancy, 'Philosopher-king', 133), which could be reflected in the fact that she, rather than Bredei's father, is named in the Pictish king-lists. Bredei's father may have been Dargart of Cenél Comgaill (*ibid.*, 130–3), which would fit the name pattern since the name Dargart is not found for any Pictish king in the king-lists.

<sup>75</sup> See below, 43–7, for further discussion of Onuist son of Uurguist and of the breakdown of the name pattern.

<sup>76</sup> There were two more likely depositions, in 778 (of Elpin son of Uuroid) and in 788, 789 or 790 (of Canaul son of Tarl'a): Elpin has a reign of three-and-a-half years in SL, which would probably give 778 (before his death recorded in AU 780.5, ARC §\*211.2, and *Annals of Clonmacnoise* (ed. Denis Murphy, *The Annals of Clonmacnoise being Annals of Ireland from the Earliest Period to A.D. 1408* [Dublin, 1896; repr. Felinfach, 1993] [hereafter AClon]) 773.1 counting from the death of his predecessor, Ciniod son of Uuredech in 775; and Canaul was a Pictish king according to SL, but he was defeated by his successor Castantin son of Uurguist according to AU 789.11 and AU 790.7 (which may be a duplicate of the first battle). Since Castantin probably ruled for thirty-two years until 820, Canaul may have lost the kingship in 788 or in the following two years, but survived until he died in a battle in Kintyre in 807: AU 807.3.

Table 2: Kings common to *Series longior* and *Series breuior* from Cruidne son of Cinge to Drest son of Munait. (Some name forms have been standardised, but otherwise they are those of SL1.)

Cruidne <i>f.</i> Cinge <sup>a</sup>	Gartnait Diuberr
Gilgidi	Talorc <i>f.</i> Achiuir
Tharan	Drest <i>f.</i> Erp
Deocilinion	Talorc <i>f.</i> Aniel
Deoord	Nectan Morbet <i>f.</i> Erip (SB Nectan Celchamoch)
Dectotr'ic <i>frater</i> Diu	Drest Gurthinmoch
Usconbuts	Galanan Erilich
Caruorst	Two Drests: Drest <i>f.</i> Girom and Drest <i>f.</i> Uudrost
Gartnait loc	Drest <i>f.</i> Girom
Breth <i>f.</i> Buthut <sup>b</sup>	Gartnait <i>f.</i> Girom
Uipoig Namet	Cailtram <i>f.</i> Girom
Canutulachama	Talorc <i>f.</i> Muircholaich
Uuradech Uecla	Drest <i>f.</i> Munait

<sup>a</sup> Enge in SL1: from the readings of other witnesses, it is likely that SL's original reading was *Cinge*.

<sup>b</sup> Breth *filius* Buthut is not found in any SB list except perhaps John of Fordun's, where there is a *Blarehassereth* with *xiii* years after Uipoig namet instead of Breth's *uii* in SL1. The name given by Fordun could possibly have been derived from *Breth* with *l a* (for fifty *annis*) *regnasse* added between *B* and *reth*, but the source of the potential intrusion is unclear to me.

existing system, part of the ideology of which was that kings should not be succeeded by their sons.<sup>77</sup>

A striking feature of the king-lists is that the pattern of the historical section before 730 – that sons did not succeed their fathers, and fathers did not have the same names as kings – is also found in the prehistoric section before King Galam Cennaleph shared by both the *Series longior* and *Series breuior* versions of the Pictish king-lists (Table 2). Some of the prehistoric section of the king-lists may have been derived from different sources (perhaps other king-lists),<sup>78</sup> or some may have been original parts

<sup>77</sup> See Henderson, *The Picts*, 32. It could be speculated that this could possibly explain the depositions of some of the Pictish kings, for instance Drest son of Donuel in 671 and Nectan son of Derelei in 724, since in these cases, having succeeded their brothers, their families had provided kings for fifteen and twenty-eight years respectively. This would increase the potential for them to accumulate the wealth and power needed to ensure the succession of their children, which would perhaps enhance the fears of exclusion felt by other potential royal claimants.

<sup>78</sup> James Fraser has suggested to me that some of these names could have been from another king-list. Certainly, such a compilation might also account for the chronological difficulties in the 770s and 780s, but the large and sometimes rounded reign-lengths of many kings up to Drest Gurthinmoch (for instance Gartnait Diuberr has a reign-length of 60 years, Talorc *f.* Achiuir 25 (SB) or 75 (SL) years, Drest *f.* Erp 100 years, Drest Gurthinmoch 30 years) supports the view that most of the prehistoric section is largely an artificial construct.

of the king-list,<sup>79</sup> but they would be expected to reflect the ideology of the lists when they were added or subjected to later alteration. Such prehistorical sections often reflect the ideological concerns of the authors more completely than historical ones, so it is significant that the main characteristics of the seventh and early eighth centuries are also present in the early part of the Pictish king-lists; while many kings in this section do not have patronymics, the eleven patronymics that were clearly part of the archetype do not show any relationship to previous kings. It is possible that some of the epithets, which were included sometimes instead of patronymics, denoted a person's ancestry, but none of them resemble the names of previous kings. Other similarities with the section from Galam Cennaleph onwards are the joint reign of Drest son of Girom and Drest son of Uudrost, and perhaps three cases (only one of which is certain) of brothers succeeding each other.<sup>80</sup> The prehistoric section of the king-lists, therefore, represents a back-projection into the distant past of contemporary Pictish succession patterns. It supports other evidence from the historic period, but unlike Bede's somewhat vague description produced from an outside perspective, the prehistoric section of the king-lists provides us with an ultimately more valuable view of how the Picts themselves perceived their kingship and its succession system.

As has already been argued, the predominant feature of Pictish succession in the period from the late sixth century to the mid-eighth century is the lack of father-to-son succession. This feature over-rode potential claims through matriliney or patriliney, so it is likely that it was an intentional restriction. Other features of Pictish succession were compatible with this prohibition; the succession of brothers or of sons of outsiders would not have been as much of a problem as in more restricted succession-systems, because it would not have caused disputes between their sons, and joint-kingships could also have been acceptable, as a

---

<sup>79</sup> There is no reason to suppose that the kings immediately before Galam Cennaleph and Bredei son of Mailcon could not have been actual kings, just because Bede's 'Ecclesiastical History', Adomnán's 'Life of St Columba' and the Irish chronicles (with the potential exception of Drest son of Uerp in AClon *s.a.* 449) do not describe Pictish events earlier than *c.*560. If so, this reinforces the evidence for the patterns of succession from *c.*560 onwards.

<sup>80</sup> The certain instance of brotherly succession is the joint-kingship of Drest, Gartnait and Cailtram, sons of Girom. There are also two less certain cases: Dectotr'ic, described in SL1 as *frater Diu* (perhaps *Dui*, according to Marjorie Anderson, *Kings*, 246 n.73), and as *frater Tui* in SL2 MSS. OHM. This brother may have been considered to have been Deocilinion or Deoord (*Duordegel* in the *Series breuior* archetype). The other case is only found in SL, which has reigns for Drest and Nectan son of Uerp. However, in this instance SB has *Celchamoch* instead of SL's patronymic and epithet, so it is uncertain if it was in the Pictish king-list archetype.



means of dividing power between potential rivals.<sup>81</sup> Also, the succession of brothers and the sons of outsiders, as was the case with Talorgan son of Ainfrith, king of Northumbria, in the mid-seventh century, would not have created such difficulties, since this would not have caused disputes between their sons over the succession. Such a system may have had the effect of preventing a single kin-group lineage from dominating the kingship.

While certainty in the matter is impossible, it is reasonable to argue that the name pattern discerned for Pictish kings should be interpreted in relation to this prohibition, reflecting an important aspect of royal ideology.<sup>82</sup> As Isabel Henderson suggested in *The Picts*, the naming system was probably devised to prevent sons succeeding their fathers, since it would be obvious at birth who could or could not be king.<sup>83</sup> In addition, where sons could not succeed their fathers there was a danger that sons would attempt to prevent their fathers from gaining the kingship, because this would disqualify the sons from the succession.<sup>84</sup> The name system may have prevented this type of conflict by predetermining which of the two could become king. Therefore, the name pattern could have acted as a stabilising force both within the immediate family and within the dynasty as a whole, supporting a prohibition on father-to-son succession.

Given the changeability of early medieval succession practice, it could be argued that the idea of such a system among the Picts, with a seemingly rigid set of rules, is unlikely. However, elsewhere there were ideological frameworks determining royal succession, which could be subject to debate and regulation. Examples of this are the ecclesiastical councils in seventh-century Visigothic Spain, which created rules of succession using the election of aristocrats to the kingship, and Frankish written arrangements for the succession decreed by Charlemagne in 806 and Louis in 817, although it should be stressed that often such regulation was not very successful.<sup>85</sup> In such systems, change usually did not involve

---

<sup>81</sup> In this system, the succession of brothers may in fact have had a beneficial effect for other claimants, since the sons of any brothers could not then be king.

<sup>82</sup> Molly Miller, 'Eanfrith's Pictish son', *Northern History* 14 (1978), 47–66, at 51 n.18.

<sup>83</sup> Henderson, *The Picts*, 32.

<sup>84</sup> For instances of conflict between fathers and sons over kingships, see Wood, 'Kings, kingdoms', 11–12.

<sup>85</sup> Roger Collins, *Visigothic Spain 409–711* (Oxford, 2004), 88–90; *Carolingian Civilization. A Reader*, ed. Paul Edward Dutton (Cardiff, 1993), 129–33, 176–9. It is notable that the Visigothic council resolutions were sometimes flouted in practice and that Julian of Toledo's stress on Toledo as a place of royal anointing was one method of strengthening the legitimacy of the king, to counter this instability: see Roger Collins, 'Julian of Toledo and the royal succession in late seventh-century Spain', in *Early Medieval Kingship*, ed. Sawyer and Wood, 30–49, at 46–9.

a total break with all aspects of the previous pattern; there was often an attempt to balance innovation and previous practice in a way that was politically most expedient.<sup>86</sup> Therefore, succession practice was affected by a wider societal discourse concerning the nature of kingship and society.

Unfortunately, it is not possible to determine whether the Picts produced codified rules of succession, but their repetition of certain succession practices indicates that there were clearly factors which prevented or assisted potential candidates claiming the kingship. The fact that elements, such as the name pattern and the lack of father-to-son succession, were maintained without exception for the Pictish over-kingship for a long period until the mid-eighth century demonstrates that there existed strong societal pressures for the maintenance of these practices.<sup>87</sup> In light of this, the idea of a succession ‘system’ is not an invalid concept, so long as it is used loosely, being viewed in terms of expectations concerning who was suitable for the kingship, and how the succession was determined, rather than as a set of unchanging rules. It should also not be assumed that everyone would have held identical views on the matter, or that there was no conceptual development over time.

*The dynastic relationships of Pictish kings in the seventh century*

It is more difficult, however, to determine how the Pictish succession from the late sixth century to the mid-eighth century worked in detail, since our sources do not allow royal dynasties to be reconstructed with any certainty. There are, however, some small pieces of evidence for seventh-century kings to supplement Bede’s account, which have been used to create a Pictish royal dynasty. Molly Miller and Alex Woolf have argued for the existence of a dynasty which provided kings of both the Picts and the Britons of *Al Clut* (Dumbarton Rock on the Clyde estuary), although, whereas Miller explained this in terms of Pictish matriliney, Woolf proposed a patrilineal succession.<sup>88</sup> Both, however, argued that the Pictish kings Nectan *nepos* Uerp, Gartnait, Bredei and Talorc, sons of Uuid, Talorgen son of Ainfrith and Bredei son of Bile were members of this dynasty. If this is correct then it might be possible to use this to reconstruct how the succession system worked in practice. Unfortunately,

---

<sup>86</sup> See, for instance the use of territorial division between heirs among the Franks: Wood, ‘Kings, kingdoms’, 6–7, 9–17, 23–6.

<sup>87</sup> It could be that change during this period was mainly in terms of which groups within the dynasty and perhaps kingdom would control the kingship, and whether brothers and outsiders would succeed. These differences could be resolved by working within the parameters of the name system and the prohibition on father-to-son succession.

<sup>88</sup> Miller, ‘Eanfrith’s Pictish son’, 47–66; Woolf, ‘Pictish matriliney reconsidered’, 159–64.

the evidence for the relationships between many of these kings is weak, but a few insights into succession practice can still be gained nonetheless.

The main evidence for the theory that these kings were from the Dumbarton royal dynasty is the correspondence of their names with those found in the genealogy of the British kingdom. This was compiled with others in the late tenth century (950x88), and survives in the Harleian MS. 3859, written *c.*1100 in England or on the Continent.<sup>89</sup> This genealogy includes *Eugein map Beli map Neithon map Guipno map Dumngual hen*. *Eugein* is likely to have been the *Hoan* who, according to the Irish annals, fought in 643/4 on the British side in the battle of Strathcarron, and whose grandfather was called *Nwython* in a stanza on the same battle in *The Gododdin*.<sup>90</sup> Since Bredei son of Bile is described as the son of the king of Dumbarton in a poem found in the tenth-century *Betha Adamnáin*, it is quite likely that the *Beli* of the genealogy was his father, making him *Eugein*'s brother.<sup>91</sup>

However, the rest of the reconstruction, which is just about possible in terms of chronology, is based on inferences from names and other weak evidence for inter-relationships.<sup>92</sup> The sons of Uuid were identified as the offspring of *Guipno* by Miller, who proposed that Uuid was the Pictish version of the name Gwyddno, assuming that the *p* was a miscopying of an earlier Old English *p*.<sup>93</sup> This also assumes that the final element *-no* would not have been present in Pictish. This identification should be viewed as possible, but unprovable with our current knowledge of Pictish.

---

<sup>89</sup> *Early Welsh Genealogical Tracts*, §5, ed. P. Bartrum (Cardiff, 1966), 10. For the date-range of the compilation, see David N. Dumville, 'Historia Brittonum: an Insular history from the Carolingian age', in *Historiographie im frühen Mittelalter*, ed. Anton Scharer and Georg Scheibelreiter (Vienna, 1994), 406–34, at 406, and for Harleian MS. 3859's date and discussion of the manuscript, see AC, vi–vii.

<sup>90</sup> AU 642.1, AT kl. 144.2, CS 640.1; K. H. Jackson, *The Gododdin: the oldest Scottish poem* (Edinburgh, 1969), 98–9, 147.

<sup>91</sup> Woolf, 'Pictish matriline reconsidered', 159–60.

<sup>92</sup> However, it does involve some long generations for it to work, since Rhydderch *Hen*, great-grandson of Dyfnwal *Hen*, was king during the time that Columba was in Britain from 563 to 597, which would mean that Dyfnwal's birth took place in 517 or earlier if there were twenty years per generation and Rhydderch was twenty when he became king. Dyfnwal was the father of Guipno, whom Miller proposed was the father of both Nectan *nepos* Uerp and the sons of Uuid (ruling A.D. 632/3–53?). For this to work the generation before Rhydderch *Hen* from Guipno's branch would have to have ruled perhaps fifty years or more after Rhydderch's death, which is possible, but its improbability reduces the likelihood that Guipno was Uuid. Similarly, Bredei son of Beli's reign from 671 to 692, probably coincided to some extent with that of the son of his brother Owain (*fl.* *c.*643/4), Dyfnwal, whose obit is recorded in AU 694.6, AT [693].2 (=A.D. 693). It is possible, however, that the Pictish succession system led to older dynasts becoming king, which would make such a scenario more plausible.

<sup>93</sup> See *Genealogical Tracts*, §5, ed. Bartrum, 10, and n.5; Miller, 'Eanfrith's Pictish son', 55. This does pre-suppose an ancestor text including some Anglo-Saxon script.

Miller, followed by Woolf, then argued that Talorgen son of Ainfrith was part of the same dynasty, because his *-en* or *-an* suffix might be a diminutive included to distinguish him from his predecessor Talorc son of Uuid, and that this might represent a connection between them.<sup>94</sup> Even if the suffix were a diminutive, and a marker of a relationship, this does not show what that relationship was, as is demonstrated by the fact that whereas Miller proposed that Talorgen could have been a grandson of Uuid, Woolf hypothesised that he was Uuid's great-grandson.<sup>95</sup>

However, it is safe to argue that Talorgen's link to the Pictish dynasty was through his mother, since Ainfrith can be identified as Eanfrith son of Æthelfrith, briefly king of Bernicia (633–4). It is likely that his Bernician royal connection could have increased his prestige and assisted his claim to the Pictish kingship, but since Eanfrith presumably stayed in Pictland as an exile in the period 616/18 to 633, Talorgen's mother probably was a Pict and brought him up in Pictland.<sup>96</sup> Talorgen's case, as in Bredei son of Bile's, indicates that sons of outsiders could become Pictish kings.<sup>97</sup>

Another potential connection between the sons of Uuid and Bredei son of Bile is Nectan *nepos* Uerp; if Nectan were the *Neithon* son of *Gwyddno* of the Harleian genealogy then he could have been the grandfather whose inheritance Bredei son of Bile fought for at the battle of Dún Nechtain in 685, according to an Old Irish quatrain written no later than about 900.<sup>98</sup> Miller explained the appearance of *nepos Uerp* in the SL king-list by arguing that, based on Irish models, it meant 'descendant of Uerp' not 'grandson of Uerp'. This makes it possible that Uerp is found

---

<sup>94</sup> Woolf, 'Pictish matriline reconsidered', 159; Miller, 'Eanfrith's Pictish son', 51. Miller also argued that, 'since Talorcán I [Talorgen son of Ainfrith] is preceded by a group of three brothers and succeeded by a group of two, the dynastic situation was stable at the time', which she used to propose that all these kings were related to each other: *ibid.*, 51–2. Neither inference – that the dynastic situation was stable nor that this would necessarily indicate a familial relationship – can really be made from the scanty evidence.

<sup>95</sup> Miller, 'Eanfrith's Pictish son', 56; Woolf, 'Pictish matriline reconsidered', 161.

<sup>96</sup> See Woolf, 'Pictish matriline reconsidered', 159, where Woolf also suggests that Talorgen was adopted into a Pictish kindred as *glasfhine* and so would have gained rights of his mother's patrilineage, if the Pictish system was the same as the Irish one. However, in early Irish law, such a son was only allowed to inherit land equivalent to the honour-price of a small farmer (*ócaire*), and this was only if the mother had no brothers: Fergus Kelly, *A Guide to Early Irish Law* (Dublin, 1988), 104–5. Therefore, the principle seems to have been to give the son a limited inheritance and role in the kindred, when this property passed through the female line. The case of Talorgen son of Ainfrith implies that, at least in terms of Pictish royal succession, a comparable situation did not lead to a reduction in the son's status.

<sup>97</sup> See below, 29–33, for more discussion of Bredei's ancestry.

<sup>98</sup> Miller, 'Eanfrith's Pictish son', 53–5. Alternatively, as Woolf, has implied, the grandfather in question was Edwin, king of Northumbria: Alex Woolf, 'The Verturian hegemony: a mirror in the north', in *Mercia. An Anglo-Saxon kingdom in Europe*, ed. Michelle P. Brown and Carol A. Farr (London, 2001), 106–11, at 108.

near the end of the Dumbarton genealogy, if it is emended so that *Fer map Confer, ipse est uero olitauc*, became *Fer map Con. Fer ipse est Uerb. Clitauc*. There are serious problems with this theory. Apart from the need to suppose that two letters – *b* and *c* – become *o*, seemingly independently during its textual transmission, there is the overall problem that, even with the emendations, the rest of the sentence in the Dumbarton genealogy (*Fer map Confer, ipse est uero olitauc dimor meton uenditus est*) has not been satisfactorily interpreted.<sup>99</sup> It would seem safer not to make an emendation that does not help to make sense of the whole sentence and which may not be necessary: it is possible that both *uero* and *Fer map Confer* are not corrupt forms. *Fer map Confer* is similar to the *Cein map Guorcein map Doli map Guordoli* in the Harleian genealogy for Owen map Hywel, ruler of Dyfed, where the second name expands the first, so such a couplet need not be a mistake.<sup>100</sup> The other evidence for Miller's theory is the appearance of a Nectan in place of Gartnait son of Uuid in the SB king-lists, which she argued reflected knowledge of a king Nectan son of Uuid.<sup>101</sup> However, this could be the result of a scribal error rather than emendation.<sup>102</sup> An alternative possibility is that Nectan *nepos* Uerp was

---

<sup>99</sup> *Genealogical Tracts*, §5, ed. Bartrum, 10, and 127 n.5. Graham Isaac in correspondence has written: 'There has been some tradition of citing the form *meton* as an Old Welsh instance of what appears in Middle Welsh as *mewn*, *mywn* (which is cognate with Old Irish *medon*). Assuming that, there is a natural way – in grammatical terms – of understanding the phrases with just the minimum of emendation: deletion of *c* at the end of *olitauc*. That gives *litau*, which looks like the Old Welsh for *Llydaw*, "Brittany". This might have the alternative meaning "Latium" of its Irish cognate *Letha*. I should emphasise that *W. Llydaw* is not otherwise extant in the meaning "Latium". And *mor meton*, "middle sea", seems a plausible variant designation for what in later Welsh becomes *Y Mor Canol*, "the Mediterranean Sea". Grammatically that gives: *ipse est uero o litau[.]. di mor meton uenditus est* ("He is in fact from *Latium*. He was sold from/to [the lands of] the Mediterranean.'). Dr Isaac would like to stress that this is not a definitive interpretation, that what the text signifies, even if his analysis is correct, is not clear, and that it is completely open to further emendation to improve the sense. John Koch (in correspondence) independently has translated *dimor meton* as 'from the middle sea', and emended *litau* to *litau*, so that the meaning was either 'Armorica, Brittany', or in the more archaic sense 'continent, mainland', or 'Latium' in the learned sense.

<sup>100</sup> *Genealogical Tracts*, §1, ed. Bartrum, 9. See John T. Koch, 'The loss of final syllables and loss of declension in Brittonic', *The Bulletin of the Board of Celtic Studies* 30 (1983), 201–34, at 219–20, for the view that the names with *guor* referred to the preceding person in the genealogy.

<sup>101</sup> Miller, 'Eanfrith's Pictish Son', 54–5, where it is argued that the name and reign-length were changed, to be compensated for by later alterations, because someone knew about the fame of a Neithon son of Gwyddno from poems and sagas.

<sup>102</sup> This king Nectan's reign-length in SB is *uiii*, which is not that different from SL1 *iiii* and SL2 *uii*, so there is no need to argue for intentional alteration; the appearance of Nectan in SB could be the result of a scribal error, common in king-lists, where one king's name is replaced by another found close by in the list.

the Nectan son of Cano recorded in the Irish chronicles in AU 621.3.<sup>103</sup> However, the annal-interval of ten from this item to the obituary notice of Ciniod son of Lutrin (AU 631) does not correspond with the reign-lengths in the Pictish king-lists of nineteen years in SL and fourteen years in SB, so this identification is also very uncertain.<sup>104</sup> Overall then, the evidence for the ancestry of Nectan *nepos* Uerp is weak, although there is the possibility that his descent from a person called Uerp reflected some connection with an earlier king in the lists, Drest son of Erp.<sup>105</sup> In terms of succession practice, although the meaning of *nepos* is ambiguous, its use at least hints that it was possible that more distant lineage, as well as parentage, could be a factor in determining the succession.

The other evidence for connecting recorded Pictish kings with each other is the statement in *Historia Brittonum*, written 829/30, that Ecgfrith, king of Northumbria, fought his *fratruehus*, Bredei son of Beli.<sup>106</sup> Molly Miller argued that this link had to have been through Eanfrith, Talorgen's father, but Alex Woolf and Alasdair Ross have suggested that Bredei's link to the Bernician dynasty could have been through his mother, perhaps a daughter of Edwin, king of Northumbria (d.633) (see Fig. 2).<sup>107</sup> If this is correct then Bredei's grandfather, the Neithon of the Dumbarton genealogy, by default probably provided Bredei with his claim to the Pictish throne, through the male line, especially if he were the Nectan *nepos* Uerp of the Pictish king-list. This would also, however, still comply with the prohibition on father-to-son succession to the Pictish kingship.

This theory is a real possibility, but so are others, depending on how the word *fratruehus* is interpreted. The main meaning of *fratruehus* in Late Latin was the person's father's brother's son, but Isidore defined it as the

---

<sup>103</sup> Also AT kl. 127.3, CS 621.2.

<sup>104</sup> For the possible identification see A. O. Anderson, *Early Sources of Scottish History*, 2 vols (Edinburgh, 1922; repr. Stamford, 1991), i, 145 n.3. Using the item for Gartnait son of Domelch's death found only in AT kl. 105.2 (=A.D. 600/1/2), there is an annal-interval of twenty-two, nearly corresponding to Nectan's reign-length of twenty in SL and twenty-one in SB, but Gartnait's reign-length in the Pictish king-lists does not correspond with the annal-interval from the death of Bredei son of Mailcon.

<sup>105</sup> Drust's brother, Nectan son of Erip, is probably a duplicate of the seventh-century Nectan *nepos* Uerp since his patronymic appears only in SL and replaces *Celchamoch* in SB.

<sup>106</sup> *Historia Brittonum*, §57, ed. and trans. John Morris, *Nennius. British History and the Welsh Annals* (London and Chichester, 1980), 36, 77. See Dumville, 'Historia Brittonum: an Insular history', 406, for dating.

<sup>107</sup> Miller, 'Eanfrith's Pictish son', 55; Woolf, 'Pictish matriline reconsidered', 162; Ross, 'Pictish matriline?', 19–20. Oswald's mother was Acha. According to *Historia Brittonum*, §57 (ed. Morris, *Nennius*, 36, 77), Æthelfrith had four other sons apart from Oswald, Eanfrith and Oswy. Although the value of this is uncertain, it is quite likely that Æthelfrith had daughters as well.

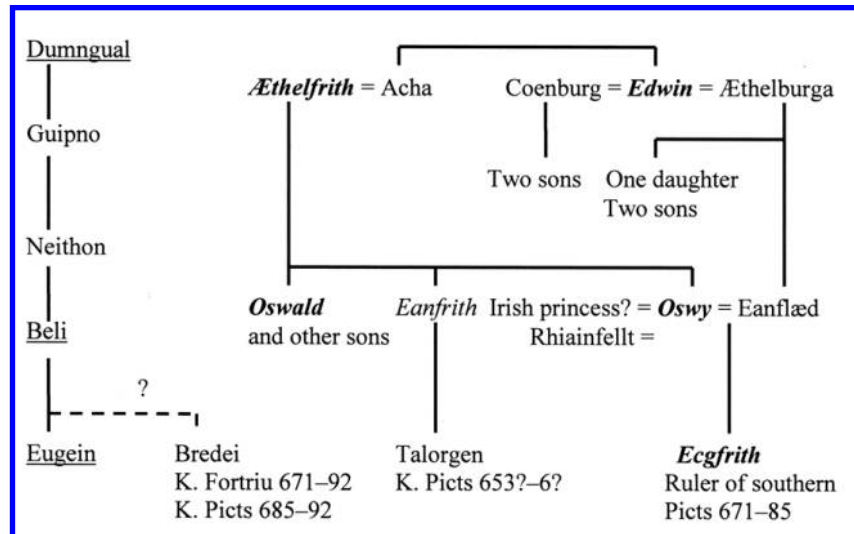

Fig. 2: The known relationships of kings of the Picts, Deira, Bernicia, and Dumbarton. (Kings of Deira are in bold, kings of Bernicia in italics, kings of Dumbarton underlined and Pictish kings are labelled as such.)

mother's sister's son.<sup>108</sup> The other meaning of *fratruelis*, found in eighth-century Anglo-Saxon England, was a brother's son or any nephew.<sup>109</sup> *Fratruelis* is used elsewhere in *Historia Brittonum*, at §38, where, in the context of Anglo-Saxon attacks on the Britons, a person called Ebissa is described as the *fratruelis* of Otha, son of Hengest.<sup>110</sup> Since Hengest was still militarily active at this point and Otha and Ebissa are portrayed as equals, it is much more likely that Ebissa was in the same generation as Otha, rather than being a younger generation. This favours the view that, for the author of *Historia Brittonum*, *fratruelis* meant cousin rather than nephew.<sup>111</sup> It is not clear, though, whether the Late Latin and

<sup>108</sup> Charlton T. Lewis and Charles Short, *A Latin Dictionary* (Oxford, 1879), s.v. *fratruelis*.

<sup>109</sup> D. R. Howlett et al., *Dictionary of Medieval Latin from British Sources, Fascicule IV, F-G-H* (Oxford, 1989), s.v. *fratruelis*.

<sup>110</sup> *Historia Brittonum*, §38, ed. Morris, *Nennius*, 29, 69.

<sup>111</sup> If Bredei were Ecgfrith's nephew, then Bredei's father, Beli, was not the son of Neithon. Oswy died in 670 at the age of 58 (*HE*, iv.5, ed. Colgrave and Mynors, 348-9), so he was born in 611 or 612, making it impossible for him to have a daughter of child-bearing age by the time of Beli's death, if this was by the time Beli's son, Owain, was king at the battle of Strathcarron in 643/4. It is just about possible that Bredei's father was an otherwise unattested Beli who was king of Strathclyde, since there were probably more kings than survive in records (see Miller, 'Eanfrith's Pictish son', 49), but the chronology is still very tight; Bredei's reign among the Picts began in 671, so he was presumably born by about 651, which is only a few years after a daughter of Oswy could have had a son at the earliest. Overall, this possibility is highly unlikely and so can probably be discounted.

Isidorian usage, whereby the parents had to be the same sex, would still have been adhered to in ninth-century Wales; it is to be suspected that siblings of different gender would also have been permitted. If, therefore, we translate *fratruelis* as any son of an aunt or uncle, then there are a number of possible ways for Bredei to have been Ecgfrith's *fratruelis*.

One possibility is that the connection was through daughters of Edwin of Deira, as Woolf and Ross have proposed, but that the mother of Beli's wife was a member of the Pictish royal family. Edwin was in exile from about 604 to 616 (or 618), when he killed King Æthelfrith of Bernicia (who had also conquered Deira), so it is possible that he stayed in Pictland for part of that time and had a daughter by a Pictish woman.<sup>112</sup> Alternatively, Edwin could have married a Pictish royal woman once he was king in Northumbria (616 or 618), since he only married Æthelburga, the daughter of the king of Kent, in 625, according to Bede.<sup>113</sup> Bede tended to mention royal women when there was a Christian or dynastic purpose; of Edwin's recorded daughters, Æthelthryd died while wearing baptismal robes, while Eanflæd was the first Christian Northumbrian and later wife of King Oswy, so it is likely that any other daughter Edwin had

---

<sup>112</sup> Bede (*HE*, ii.12, ed. Colgrave and Mynors, 176–7, 178–9) states that Edwin, while an exile from Æthelfrith (c.604–c.616/18) wandered in many lands and kingdoms 'in every corner of Britain' before going to the East Angles. One of these was Mercia, since he had two sons by Coenburg daughter of King Cearl of Mercia (*HE*, ii.14, ed. Colgrave and Mynors, 186–7), but is it possible that he also went to the Dumbarton Britons and the Picts? Certainly a close relative of Edwin, Hereric had two daughters while under the protection of the British king Cerdic (perhaps of Elmet) probably in the same period, before being killed (*HE*, iv.23, ed. Colgrave and Mynors, 410–11; Yorke, *Kings and Kingdoms*, 76), and later, after Edwin's succession, the sons of his rival Æthelfrith went north among the Picts and Gaels, so it is possible that Edwin stayed among the Picts for a while. Given that he had two children while in Mercia, and four more from 625 to 633, it seems quite likely that there were other children. There is some later evidence from the Welsh Triads that Edwin may also have been in exile in Gwynedd: Clare Stancliffe, 'Oswald, "Most holy and most victorious king of the Northumbrians"', in *Oswald. Northumbrian King to European Saint*, ed. Clare Stancliffe and Eric Cambridge (Stamford, 1995), 33–83, at 38. On the different dates for the end of Æthelfrith's reign, see Susan Wood, 'Bede's Northumbrian dates again', *English Historical Review* [hereafter *EHR*] 98 (1983), 280–96, and Woolf, 'Pictish matriline reconsidered', 162.

<sup>113</sup> *HE*, ii.9, ed. Colgrave and Mynors, 162–5. The theory that Bede made a mistake and that Edwin and Æthelburga actually married in 618 or 619 involves taking too rigid a view of the meaning of Bede's text. For this theory, see Peter Hunter Blair, 'The letters of Pope Boniface V and the mission of Paulinus to Northumbria', in *England before the Conquest. Studies in primary sources presented to Dorothy Whitelock*, ed. Peter Clemoes and Kathleen Hughes (Cambridge, 1971), 5–13, at 9–13; D. P. Kirby, 'Bede and Northumbrian chronology', *EHR* 78 (1963), 514–27, at 522–3.



could have escaped the documentary record.<sup>114</sup> In either scenario such a daughter could then have become married to Beli, passing on a claim to the Pictish throne to their son Bredei.

Other possibilities are that the common ancestor of Bridei and Ecgfrith was Ecgfrith's grandfather, King Æthelfrith, or Æthelfrith's wife Acha (who was probably the mother of Oswy, Ecgfrith's father), sister of Edwin.<sup>115</sup> Æthelfrith, who ruled Bernicia from about 592 to 616 or 618, conquered Deira perhaps in 604, so he could have married Acha after this conquest.<sup>116</sup> Acha could subsequently have been replaced by a Pictish wife when Æthelfrith began trying to assassinate her brother, but it is also possible that Æthelfrith had a Pictish wife before he conquered Deira. The result could have been a daughter who later married Neithon, father of Beli, providing Bredei with a claim to both Pictish and British kingships. Alternatively, before marrying Æthelfrith in 604, Acha could have married Neithon, or she could have married a Pictish royal, giving birth to a daughter who later married Beli.<sup>117</sup>

---

<sup>114</sup> *HE*, ii.9, ii.14, iii.15, ed. Colgrave and Mynors, 164–7, 186–9, 260–1. For Bede's attitude to royal women, see J. M. Wallace-Hadrill, *Early Germanic Kingship in England and on the Continent* (Oxford, 1971), 91–3. It is also notable (Stancliffe, 'Oswald', 38–9) that Bede does not mention the marriage of Oswy to the Briton Rhiainfell, which is indicated by *Historia Brittonum* and the Durham *Liber Vitae*: David N. Dumville, 'The origins of Northumbria: some aspects of the British background', in *Britons and Anglo-Saxons in the Early Middle Ages* (Aldershot, 1993), ch.3, 1–14, at 12, a revised version of a chapter in *The Origins of Anglo-Saxon Kingdoms*, ed. S. Bassett (London, 1987). Nor does Bede mention Eanfrith's son and Pictish king, Talorgen. Bede's ambiguous statement about the parentage of Aldfrith (king of Northumbria 685–705), may be another example, if his mother were Gaelic: J. M. Wallace-Hadrill, *Bede's Ecclesiastical History of the English People: a historical commentary* (Oxford, 1988), 232–3. It is possible, then, that Bede had a special reluctance to mention relationships of Northumbrian kings with Britons, Picts and Gaels, and their resulting offspring, although it could be because it would have been rare for these women to have directly influenced internal Northumbrian religious and dynastic affairs that were more pertinent to Bede's work.

<sup>115</sup> *HE*, iii.6, ed. Colgrave and Mynors, 230–1, states that Oswald was Edwin's nephew by Edwin's sister Acha, from which it has been assumed that the mother of Oswy, Oswald's brother, was also Acha. *Historia Brittonum*, §63 (ed. Morris, *Nennius*, 38, 79), states that Æthelfrith had a wife called Bebbha, but this is likely to be a later tale designed to explain the name of Bamburgh, a major Bernician stronghold, so Æthelfrith probably did not have a wife of that name.

<sup>116</sup> Yorke, *Kings and Kingdoms*, 76–7.

<sup>117</sup> If Acha married a Pictish royal male producing a daughter then Bredei's succession would have been through both the male and female lines. Woolf has rejected the possibility that Neithon/Nectan married Acha, because Neithon and Æthelfrith died very close to each other, giving little time for a wife to move from one to the other. However, in Woolf's article Neithon's death-date of 621 seems to have been derived from the obit of Nectan son of Cano (AU 621.3, AT kl 127.3, CS 621.2 [=A.D. 622/3?]) in the Irish annals, but Woolf himself has rejected the identification of these two figures, so Neithon's death could have been earlier or later than this. Unfortunately, comparing the reign-lengths in the Pictish king-lists with the Irish chronicles is problematic, since they cannot be

It is not really possible to choose between any one of these possibilities or the theory offered by Ross and Woolf, but the main point is that Bredei's claim to the Pictish throne could have come through either the male or the female line; we do not have sufficient evidence to rule out these potential scenarios. More positively, while Bredei's connection with the Pictish royal dynasty is not clear, and could have been weak, his Pictish name indicates that he had been residing among the Picts, and was probably raised as one of them. It may be that his connections with the Dumbarton Britons, and with the dynasty of Deira or Bernicia, were significant factors in aiding his succession to the kingship of Fortriu at a time when southern Pictland was dominated by Northumbria.

Overall, then, whereas there is strong evidence that Bredei son of Bile was from the Dumbarton royal dynasty, the evidence pointing to a similar conclusion for the sons of Gartnait, Nectan *nepos* Uerp and Talorgen son of Ainfrith is weak. However, this analysis does provide some evidence for Pictish succession: sons of outside dynasts and grandsons or more distant descendants of previous kings could succeed, and there is nothing that contradicts the interpretation proposed above of the account of Pictish succession in Bede's 'Ecclesiastical History', the Pictish king-lists and the Irish chronicles. It also shows the importance of royal names; even when the father was not a Pict, the sons who became Pictish kings were given royal names. This would be more likely if the parents were also residing in Pictland. We know that Eanfrith, the father of Talorgen, was in exile before 633. It is possible that Beli, father of Bredei, was also exiled in Pictland, but a marriage alliance, with Beli living in Pictland, bringing up his son as a Pict, is another possibility. It would seem that the Pictish system was flexible enough to incorporate such people into its kingship, although the exact circumstances in each case are hazy.

---

reconciled in this period. Working backwards from the obituary notice of Ciniod son of Lutrín (AU 631, AT kl 135.2, CS 631), which was probably originally A.D. 632 or 633 (Evans, *Recording and Re-interpreting History*), Ciniod's king-list reign-length of fourteen (SB) or nineteen (SL) years would make his reign start, and therefore Nectan's reign end, in A.D. 613, 614, 618 or 619. The latter two dates would be too close to Æthelfrith's death, but the former two would give Æthelfrith time to have children by Nectan's widow. However, it is difficult to decide which date is correct, since the reign-lengths of Nectan and his immediate predecessors in the king-list do not fit with the chronology of their obituary notices in the Irish annals; one or both of these sources is incorrect. It would seem to be unwise to exclude the possibility that Ecgrith and Bredei had the same grandmother in this way, especially as it is not clear that Nectan *nepos* Uerp was actually Neithon of Dumbarton. If Nectan were not Neithon, then Neithon's *floruit* and death could have been earlier (since his grandson was militarily active in the 640s), increasing the plausibility of the theory that Acha, or another woman, was involved with Æthelfrith after Neithon's death.

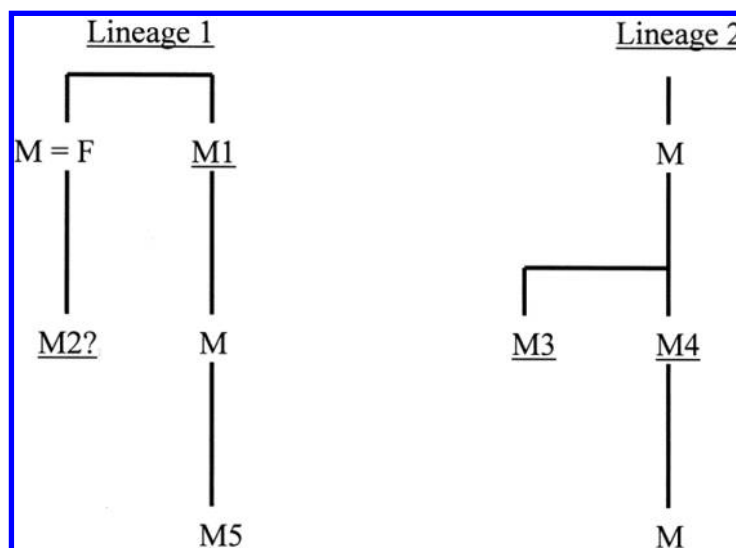

Fig. 3: A patrilineal succession model.

#### *Models of Pictish succession before 730*

While it is not possible to reconstruct a royal family tree for the Pictish kingship in the seventh century, it might be possible to reconstruct models, taking into account the implications of Bede's statement that there was a royal dynasty, as well as the patterns that kings were not succeeded by their sons, and that kings have 'royal' names, but their fathers do not. These account for the existing evidence and can be used to provide further insights into the nature of Pictish kingship. If patriliney were practised (Fig. 3, Lineage 1), then the implication of the prohibition on the succession of kings' sons and of the name pattern would be that the kingship would skip the sons of kings (who would have non-royal names) to the grandsons (who would have royal names) of the previous kings (from M1 to M5). In Fig. 3 M denotes a male, F a female, underlining indicates those with royal names, and those numbered are males who became king.

The difficulty with this system is that the grandchildren (if there were any) might not be old enough to succeed their grandparents' generation, although the succession of brothers would make this more plausible. To get around this difficulty the son of a sister of the grandparents' generation (M2) could perhaps have been made king occasionally. This could explain the appearance of sons of outsiders, like Talorgen son of Ainfrith (Eanfrith of Bernicia), as kings of the Picts, although there would have been a danger that a new rival royal patriliney would be created. The main problem with this single dynastic lineage model, however, is that there seems to be no obvious reason for the prohibition on sons of kings

becoming king, and the name pattern would probably over-restrict the number of candidates.

It would become more understandable, however, where there were competing segments of the same dynasty, or an alternation between two dynasties (Fig. 3, Lineages 1 and 2). The prohibition on father-to-son succession would enable the other segment to get a chance with the kingship (with kings M3 and M4). However, the name pattern would still perhaps be mainly a hindrance, making it more difficult for each group to produce suitable candidates. In addition, the succession of sons of outsiders, like Talorgen son of Ainfrith, would still threaten one of the lineages' hold on the rotation, and would be less necessary. Also, the succession of brothers could prevent a generation of the opposing lineage becoming king (although this could be acceptable when there was no suitable candidate from the other lineage). With this name system it would be difficult for other dynastic segments without kings in recent generations to know whether to give someone a royal or non-royal name in any particular generation, which could affect the likelihood of someone becoming king.<sup>118</sup>

The model which seems to explain the succession pattern best is a matrilineal system with a large royal dynasty, in which the succession passed to the sister's son of the previous king, or another person through the female line, thus avoiding the succession of the king's son. In one scenario using this model (Fig. 4), a king (M1) is succeeded by his brother (M2), then his sister's sons (M3, M4 and M5). The kingship is then taken by M6, the sister's son of M3–5, but after his reign the succession passes back through the other sister of M1 and M2, so that M7 and M8 become kings. In this model, sons would not succeed their fathers to the kingship but grandsons could, if the son of the previous king married a royal female of another segment (for example M8, grandson of M3).<sup>119</sup> Patrilineal lineages could still be significant (see, for instance, the descent in the male line from the father of M3–5 to M8, and from M1 to M6), with the kingship to some extent alternating between them

---

<sup>118</sup> This makes the theory of a simple rotation between different groups (albeit with intruders), as proposed by Smyth, *Warlords*, 70–5, unlikely.

<sup>119</sup> In Fig. 4 (and Fig. 1), first-cousin marriage, which would make it easier to alternate the kingship between patrilineages and increase the likelihood that grandsons could succeed, has been avoided, since it is possible that such unions would have been prohibited. Miller, 'The last century', 54, stated that, 'considerations both of comparative anthropological material and of canon law suggest that first-cousin marriages would be avoided', but she later changed her viewpoint ('Matriline by treaty', 152): 'cousin marriage may be permitted or preferred: we have no evidence either way for the Pictish kings'. Certainly, in Anglo-Saxon Northumbria King Oswy married his first cousin Eanflæd c.651 (see above, 30, and Bede, *HE*, iii.15, ed. Colgrave and Mynors, 260–1), although this was a potentially highly political move by Oswy to marry into the Deiran royal dynasty, so it could be exceptional.

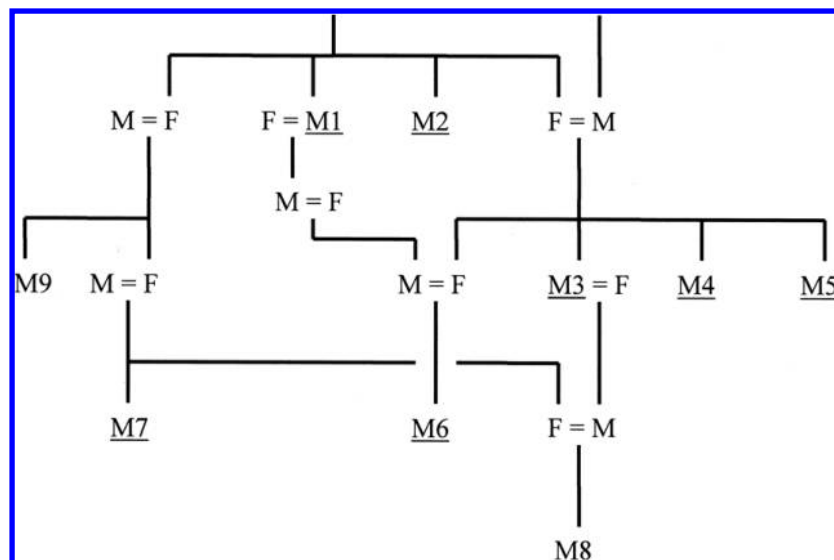

Fig. 4: A matrilineal succession model.

through marriages, although it is questionable whether such lineages would have been viewed as separate, given the possibility of frequent intermarriage.<sup>120</sup> The frequent succession of brothers, which, according to Bede, probably would usually have been when the succession was not in doubt, would often have allowed time for the next generation to become adults, thereby increasing the number of candidates for the kingship.<sup>121</sup>

However, it has to be realised that, given the large number of depositions of Pictish kings in the period from 670 to 730, the tidy succession to the kingship portrayed in Fig. 4, with mainly the succession of sisters' sons, is likely to be a simplification. The same forces which led to people from different segments becoming king in other polities would also have operated for the Picts, so the possibility that people from remote branches (like that which produced M7, but perhaps more remote), were able to succeed by force should be incorporated into any model, by assuming that the succession involved a wider kin-group than that depicted in Fig. 4. Any sons of women with royal ancestry solely through the female line (for instance M9, descended from M1's sister) would be eligible, and have followed the name pattern, but the sons of people like M9 presumably would not be legitimate candidates. The chances of gaining the kingship would decrease with every generation for

<sup>120</sup> Sellar, 'Warlords, holy men', 41; Miller, 'Matriliney by treaty', 151–3.

<sup>121</sup> See above, 2–5.

such branches, so marriage to people from outside royal dynasties, such as the Bernician Ainfriht, father of the Pictish king Talorgen, might have been tempting as a means of increasing a line's prestige and resources.<sup>122</sup> Fear of a decline in power and wealth caused by decreasing proximity to the kingship could be an important factor accounting for some of the many depositions recorded in the Irish chronicles.

Overall, then, the name-pattern and the prohibition on the succession of kings' sons could work with both patriliney and matriliney if eligibility was not restricted to a small kin-group, although the system would be more explicable if succession went through the female rather than the male line, which would explain Bede's statement that when the issue was in doubt the succession was decided through a person's female rather than male ancestry. It is unlikely that the kingship was being rotated systematically between different dynasties, perhaps kingships, in the Pictish polity, as Alfred Smyth proposed, because of the succession of brothers for long periods, and the difficulties which the prohibition on father-to-son succession and the name system would cause in ensuring that someone eligible and suitable was available from the right dynasty at the correct time. In the one certain case we do have, Talorgen son of Drusten, king of Atholl, in the first half of the eighth century, of a named king of another Pictish region, his name breaks the pattern for the over-kingship.<sup>123</sup> It is possible that the name system was only used for the over-kingship, and was derived from practice in the royal dynasty of Fortriu.

#### *Visigothic kingship: a comparison*

The implications of the Pictish succession system for the polity as a whole are difficult to determine, but a useful comparison can be made with the Visigothic kingdom in Iberia in the period from the sixth century to its conquest by Islamic invaders in the early eighth century. In Visigothic Iberia a royal dynasty was unable to establish itself (apart from the years 568–603, when members of King Leovigild's dynasty ruled).<sup>124</sup> This was the result of the end of the Balt line of kings in the early sixth century, followed by indirect Ostrogothic overlordship, and the existence of a powerful aristocracy, which was to some extent a continuation of the Roman provincial polity. The Visigothic aristocracy took the opportunity

---

<sup>122</sup> A possible condition of such marriages may have been that the son was brought up by the Picts, and had to forego any claims he might have to the kingship of his father's people.

<sup>123</sup> Another probably important Pict whose name did not adhere to the name pattern was Elpin son of Nectan (d. AU 693.1; AT [692].2, =A.D. 692).

<sup>124</sup> Collins, *Visigothic Spain*, 41–68, and 113–16 for conclusions.

to prevent the domination of any one group and the creation of a royal dynasty, particularly after the reigns of Leovigild's family.<sup>125</sup> Instead kings were chosen from a small group of aristocratic families, or were deposed and replaced in coups by another member of the aristocracy. While sons of kings did occasionally manage to succeed, their reigns were brief and often ended in deposition.<sup>126</sup> Although the early medieval Picts did not have the same Roman political or socio-economic inheritance as Spain, and chose their kings from a royal dynasty (albeit probably a large one) rather than an aristocracy, there are clearly strong parallels regarding the avoidance of father-to-son succession, so it is pertinent to consider whether related issues in the Visigothic polity would also have been relevant to the Picts.<sup>127</sup>

In Visigothic Spain there was the danger that the frequent changes in the family holding the kingship would result in perpetual political upheaval, with those ascending to power taking the chance to attack their opponents and appropriate their lands and support, avenging previous confiscations. While this did take place, often confiscations of land and banishments into exile were reversed under aristocratic pressure, and attempts were made by ecclesiastical councils to regulate and legitimise the succession system.<sup>128</sup> A distinction was also made between private property belonging to the king's aristocratic family, and property obtained while the person was king, which was counted as public and non-hereditary, being passed on to subsequent kings. This was intended to prevent kings from turning royal property (including confiscations) into private possessions, and thus to avoid a concentration of wealth and power in one aristocratic family from arising.<sup>129</sup>

While the Pictish over-kings were drawn from a dynasty, rather than an aristocracy, so change on the succession of a new king would not always have been so drastic, the lack of father-to-son succession meant that it was likely that the kingship was shared among the wider royal dynasty. Unlike in more straightforward hereditary kingships, inheritance

---

<sup>125</sup> *Ibid.*, 50–73 for the reigns of Liuva, Leovigild, Reccared, and Liuva, Reccared's son, 73–110 for the seventh century.

<sup>126</sup> *Ibid.*, 73, 75–7, 81–5, 108–9.

<sup>127</sup> This does not mean that Roman influence on the Picts was not significant; Roman pressure may have resulted in the consolidation of larger Pictish groupings, such as the Uerturiones, there would have been diplomatic and material contacts, and Picts could have been active in the empire. See, for instance, the inscription at Colchester, dated to between 222 and 235, recording a dedication by a certain Uepogenus, called a Caledonian: Jackson, 'The Pictish language', 137–8. Potentially some Roman organisational and political concepts could have been adopted by the Picts.

<sup>128</sup> Collins, *Visigothic Spain*, 80, 82, 86–8, 95, 111–12, 114–15.

<sup>129</sup> *Ibid.*, 86–8.

of royal and familial property would be unlikely to coincide, so, as in Visigothic Spain, there was still a need to keep separate these two types of property, and to prevent confiscations and banishments when there was a change of regime, to keep a balance between different segments of the dynasty. This would still have been an issue when, as took place in both polities, the succession was the result of a coup, since the protagonists might purport to be rectifying injustices committed by the removed regime.

Visigothic Spain also offers a relevant comparison for how the Pictish kingship could have been legitimated in the absence of a linear succession system. In Visigothic Spain different methods were used, the most notable being the use of Church councils which not only regulated the succession, but in doing so also provided ecclesiastical support.<sup>130</sup> In the late seventh century, this was complemented by the stress placed by Julian of Toledo and others on the special status of the king, because he had been anointed at the episcopal centre of Toledo.<sup>131</sup> While there is no directly comparable evidence for the Picts, there is some evidence, albeit mainly after the early eighth century, for the use of the Church to present the kingship as divinely sanctioned. A close relationship between the Pictish Church and the over-kingship could be indicated by the role played by Nectan son of Derelei in deciding the type of Easter table used throughout his realm, and also perhaps by the frequent appearance of secular scenes accompanying Christian imagery in Pictish sculpture.<sup>132</sup>

The Pictish king-lists could have been another means of legitimising succession practice, since, as has been discussed above, the common source of the lists depicts a kingship lacking father-to-son succession back into the distant past.<sup>133</sup> While the common source can be dated to 834x76, it is quite possible that many of the prehistoric kings were included much earlier than that because the list probably already existed in some form by the reign of King Gartnait son of Donuel (656?–63?). If

---

<sup>130</sup> *Ibid.*, 80, 88–9.

<sup>131</sup> Collins, 'Julian of Toledo', 45–6.

<sup>132</sup> *HE*, v.21, ed. Colgrave and Mynors, 552–3; Sally M. Foster, *Picts, Gaels and Scots*, 2nd edn (London, 2004), 91–3. A note on the foundation of Abernethy (ed. Anderson, *Kings*, 247), in which king *Nectonius filius Wirp* becomes *rex omnium prouinciarum Pictorum* through St Brigit's intercession with God, could provide more evidence for links between the Church and the over-kingship, but it is only found completely in the SL1 Pictish king-list. Anderson, *Kings*, 95–6, argued that this was a later addition to the pre-existing note in all the SL lists on Abernethy's foundation, on the basis that it is not found in the Irish SL2 versions. However, it is possible that the longer note would have been of less interest to an Irish audience and so was omitted; the content and the use of Pictish orthography for *Nectonius magnus filius Wirp* would fit a Pictish context, making it likely that it was also added 862x76, perhaps from a pre-existing text.

<sup>133</sup> See above, 22–3.



the first king in the list, Cruithne son of Cinge, whose name, Cruithne, is the Gaelic for 'Pict', was also present in the mid-eighth century, then it would have served to emphasise that his successors were the legitimate rulers of all the Picts, providing a supplementary means of legitimisation, but this is not certain.<sup>134</sup> Another chronological text kept at Abernethy, which was the source for some notes included in the *Series longior* list in the period 862x76, included the reign of Drest son of Uerp in the fifth century, so it is likely that Drest's reign was part of an earlier source shared by this text and the Pictish king-lists, but not necessarily before the mid-eighth century.<sup>135</sup> However, a similar text tracing the Pictish kingship back to at least the reign of Bredei son of Mailcon in the mid-sixth century was used by Bede in his 'Ecclesiastical History' to date the arrival of St Columba in Britain.<sup>136</sup> This indicates that the stress on the ancientness of both the Pictish over-kingdom and (to a lesser extent) the succession system was present to some degree before father-to-son succession became acceptable, but our lack of comparable evidence makes it difficult to date the introduction of other potentially early ideological features.<sup>137</sup>

Another potentially comparable aspect of the Visigothic polity was that as well as a small group of aristocratic families providing candidates for the kingship, there were also unrelated local aristocracies which formed the basis of Visigothic society in the regions.<sup>138</sup> A parallel could also be drawn with ninth-century Mercia, where it seems that kings were raised up from perhaps at least three different kindreds, not necessarily based in the Mercian heartland, to become 'first among equals', since sometimes kings had attested charters of their predecessors without

---

<sup>134</sup> Cruithne son of Cinge also appears in texts in Gaelic texts on Pictish origins from the ninth century onwards: see Mac Eoin, 'On the Irish legend'; Miller, 'Matriline by treaty', as well as Nicholas Evans, 'Ideology, literacy and matriliney: approaches to medieval texts on the Pictish past' and James Fraser, 'From ancient Scythia to the First Dundee Summer School: thoughts on *The Problem of the Picts* and the quest for Pictish origins', both of which will be part of a forthcoming publication by Brill on the Picts. More elaborate statements of similar ideas are found in later versions of the Pictish king-list: Broun, 'The origin of Scottish identity', 48–52, and more recently *idem*, *Scottish Independence and the Idea of Britain*, 75–87, have discussed the territoriality of the kingship in the SL king-list. See *idem*, 'Alba', 245–9, for the stress on the kingship's antiquity and the date of the SL additions to the beginning of the list (862x76).

<sup>135</sup> See Nicholas Evans, 'The calculation of Columba's arrival in Britain in Bede's "Ecclesiastical History" and the Pictish king-lists', *SHR* 87 (2008), forthcoming.

<sup>136</sup> *Ibid.*

<sup>137</sup> It should be noted that it is uncertain whether the Abernethy chronological text was based on a source depicting a Pictish over-kingship, or just the kingship in which Abernethy was located.

<sup>138</sup> Collins, *Visigothic Spain*, 113–14, 143.

being in prominent positions.<sup>139</sup> It has also been suggested by Simon Keynes that the Mercian nobility still largely consisted of local rulers of constituent peoples, with the result that the king did not appoint local officials to some areas.<sup>140</sup>

It is difficult to perceive how closely the Pictish polity parallels either of these two cases, although there are fragments of evidence that there was a relatively large dynasty, which may have been divided into segments each with access to its own resources. This is indicated by the three- or four-way struggle in the 720s involving Nectan son of Derelei, Drest, Elpin and Onuist son of Uurguist, since most of these people must have had support from sections of the Pictish polity. These segments could have had separate geographical bases, focussed on particular Pictish territories, reflecting earlier independent regional dynasties, but the power-structures could also have been more geographically mixed than this, derived from a single dynasty which had successfully established itself in many areas. However, there is evidence for regional rulers (as has already been discussed), as well as perhaps other nobles such as the family of Finguine son of Deleroith, who died in a battle between the Picts and the Northumbrians in the plain of Manau in 711, according to the Irish annals.<sup>141</sup> It could be that there were local nobilities and kingships in Pictland with varying relationships to the Pictish over-kingship and segments of that dynasty, although the precise nature of the over-kingship dynasty's roles in regions and of the involvement of regional groups in Pictland overall is uncertain.<sup>142</sup>

The development of the Pictish succession system may have been related to some of these issues of lordship, although since the basic elements were probably present before the late sixth century, when our evidence increases, any suggestions are highly speculative. It is possible that, like the Visigothic kingship, the Pictish avoidance of father-to-son succession evolved as part of a policy to prevent the creation of

---

<sup>139</sup> Simon Keynes, 'Mercia and Wessex in the ninth century', in *Mercia*, ed. Brown and Farr, 310–28, at 314–20. It should be noted that, as with the Picts, there is no instance of father-to-son succession among the Mercians in the ninth century, only the succession of a brother (Ceolwulf's succession to Coenwulf in 821), although this could be the result of a lack of evidence for Mercian inter-relationships. However this deficiency could parallel the similar lack of evidence for the Picts, perhaps showing that these inter-relationships were not considered important.

<sup>140</sup> *Ibid.*, 320–3.

<sup>141</sup> See above, 12–14; AU 711.3, AT [711].3.

<sup>142</sup> It is possible that a reliance on local kings and nobles, or on segments of the over-kingship dynasty, rather than on appointed royal officials, for the administration of the local areas in Pictland meant that there was less need for administrative documents. Keynes has suggested that the scarcity of surviving Mercian charters from some parts of that kingdom could reflect the reliance on rulers of local peoples rather than on royal officials and administration: Keynes, 'Mercia and Wessex', 322.

a concentration of power in a small dynasty.<sup>143</sup> This could have been the result of pressure from an enlarged royal dynasty after the kingdom of Fortriu had extended its power, or have been a consequence of the incorporation on relatively equal terms of more than one dynasty into a single political unit. It is possible that the existence of such a large dynasty in which kingship was not restricted to a close-knit family group enabled the incorporation of further regional aristocracies and dynasties, by offering them the opportunity to become part of and perhaps rule a more powerful single political unit.

Potentially, then, the Pictish succession system may have facilitated the expansion of Fortriu or have been a result of it. However, there were probably limits to such processes, since not all kings and nobles were part of the royal dynasty by the early eighth century. There is no need to assume that the pattern of succession was very old, or was found in any Pictish kingship other than the over-kingship (or perhaps originally the kingship of Fortriu), since succession patterns elsewhere were often the result of adaptations to particular political circumstances.<sup>144</sup> There is, therefore, no reason to consider it more ‘native’ or pre-Celtic than any other method of succession.<sup>145</sup>

From the foregoing discussion it has been proposed that the succession system would have had many potential effects on the Pictish

---

<sup>143</sup> However, it may not necessarily have developed through being the most effective solution to individual problems faced by the polity, if the evidence of other kingships, where individual circumstances were significant, is anything to go by: Wood, ‘Kings, kingdoms’, 6–26.

<sup>144</sup> An intriguing account found in *Collectanea Rerum Memorabilium*, ed. Th. Mommsen, *C. Iulii Solini Collectanea rerum memorabilium* (Berlin, 1864), 234–5, which may be by Solinus (c. A.D. 200) if it is not a later early medieval addition (*ibid.*, xlvi), could indicate that there were antecedents in the Hebrides for later Pictish practice. This account, which was used as evidence for Pictish matriliney by Chadwick (*Early Scotland*, 92) and H. Zimmer (‘Matriarchy among the Picts’, trans. in *Leabhar nan Gleann. The Book of the Glens*, ed. G. Henderson [Edinburgh, 1898], 1–42, at 26–7), states that the five islands of the *Ebudes* (the Inner or Outer Hebrides) had a single king, who owned nothing and lived in poverty, but owned the property of all his subjects. He also had no wives; instead he could take women on loan, but he was not allowed to pray or hope for children. There are some similarities to later Pictish practice, in that presumably kings would not be succeeded by their children, and they were not allowed to use their position to build up private wealth, but it does also fit into Solinus’s exaggerated accounts of exotic islands, with weird customs and natural phenomena. For translations of some of the surrounding text, see A. L. F. Rivet and Colin Smith, *The Place-names of Roman Britain* (London, 1979), 85–6 (which omits the section on the *Ebudes*). It is possible that the account is to some extent a theoretical construct of a polity where the ruler lacks any material or dynastic temptations, as a contrast with the Roman empire, so it is difficult to determine what is accurate, exaggerated or fabricated, and therefore whether it was a predecessor in some way of later Pictish succession practice.

<sup>145</sup> The same could be said about matrilineal royal succession, if it was practised by the Picts.

polity, being a significant factor in shaping the relationships between royal, noble and ecclesiastical elite groups throughout Pictland, and perhaps the nature of royal ideology. It follows from this that the alteration of fundamental elements of the succession, such as avoidance of father-to-son succession and the end of the name pattern would have had significant ramifications for the whole of the Pictish polity, since it allowed a greater centralisation of power inside the royal dynasty, while the creation of excluded branches also perhaps increased the incentive for separatism if the over-kings were not sufficiently strong.

*Continuity and change in Pictish succession practice and kingship after 730*

As has already been mentioned, these changes did take place at some point after the early eighth century; from the reign of Ciniod son of Uuredech onwards kings appear whose fathers' names are those of previous Pictish kings, which indicates that sons could succeed their fathers, contrary to the main principle underlying earlier successions (Table 1). However, while it is recognised that this change took place at some point before A.D. 900, there has not been a consensus about exactly when it occurred. Molly Miller argued that matriliney survived in some form up to the late ninth century.<sup>146</sup> Miller did not consider Drest son of Talorgen's (778–9?) father to have been a king, but did regard it as likely that Drest son of Castantin (834–6/7) and Uen son of Unuist (836/7–9) were the sons of Castantin son of Uurguist (c.788–820) and Unuist son of Uurguist (820–34) respectively.<sup>147</sup> Despite this evidence for patriliney, Miller argued that Uurad son of Bargoit (839–41/2) and Cináed son of Alpín (842/3–58) were both acting kings only, ruling on behalf of their sons who had rightful claims under the matrilineal system, and that the system was altered to a patrilineal one by Cináed's brother, Domnall (858–62), to give his own rule a legal basis. In Miller's opinion this was followed by a brief resurgence of Pictish practice allowing the succession of Eochaid son of Rhun (878–89) through the female line before a patrilineal system was re-asserted.<sup>148</sup> For this theory to work, Miller hypothesised that Eochaid's grandfather Cináed son of Alpín had married a Pictish royal woman.<sup>149</sup> Miller, therefore, envisaged the ninth century as a period when Pictish practices of succession were still in operation, but with instances of Gaelic patrilineal succession, which ultimately became the norm.

---

<sup>146</sup> Miller, 'The last century', 39.

<sup>147</sup> *Ibid.*, 55, 63 n.42.

<sup>148</sup> *Ibid.*, 49–50, 54, using a reference to the re-establishment of the laws of Áed Find during Domnall's reign, based on the 'Chronicle of the Kings of Alba'.

<sup>149</sup> *Ibid.*, 49–50.

However, the balance of evidence favours the view that neither the prohibition on sons succeeding their fathers nor the royal name pattern were practised in the ninth century: as well as the frequent succession of sons of earlier kings (albeit not immediately), Uurad son of Bargoit possessed a name previously only used for a king's father, and Alpin, father of King Cináed, had a royal name.<sup>150</sup> The corresponding changes of nomenclature and succession practice together indicate that fundamental alterations had taken place in the system. Rather than arguing that such kings were stop-gaps in a matrilineal system, we should view them as legitimate kings chosen under different criteria. This change had taken place by 834, but can this transition be dated earlier, by finding earlier examples of sons succeeding their fathers, and a change in the name pattern?

In fact, when this evidence is analysed, it becomes probable that the most significant changes took place about a century earlier. It seems likely that the civil war of the 720s resulted in fundamental changes to the political structure of Pictland, and that an altered pattern of succession formed part of these developments.<sup>151</sup> As Dauvit Broun has tentatively proposed, the dynasty of Onuist son of Uurguist (in Gaelic Óengus son of Forghus or Fergus), king of the Picts from 729 or 732 to 761, probably dominated the Pictish kingship until the 830s.<sup>152</sup> Onuist himself was succeeded by his brother Bredei, who ruled from 761 to 763, Talorgen son of Onuist (779–82?) could have been Onuist's son, and kings Castantin son of Uurguist (c.788–820), Unuist son of Uurguist (820–34), Drest son of Castantin (834–6/7), and Uuen son of Unuist (836/7–9) could have been related to the earlier kings through Uurguist.<sup>153</sup> Therefore, Pictland was probably ruled for most of the period from 732 to 839 by a single dynasty, with sons often succeeding their fathers.

However, other kings probably unrelated to Onuist's dynasty are also found, including Cinioid son of Uuredech (763–75), Elpin son of Uroid (775–8/80?), Canaul son of Tarl'a (784–c.8?), Talorgen son of Uithoil (who ruled at the same time as Drest son of Castantin, Uurad son of Bargoit (839–41/2) and Bred (841/2–2/3), so the supremacy of Onuist's dynasty was not complete.<sup>154</sup> It would seem that power had become

<sup>150</sup> Both the names Uurad and Alpin appear before in Elpin son of Uuroid (775–8/80).

<sup>151</sup> The significance of the civil wars in altering succession practice was recognised by Miller to some extent (*ibid.*, 53), but unfortunately, Miller's view that the Picts on the whole continued to practise matrilineal succession prevented this line of enquiry being followed further.

<sup>152</sup> Broun, 'Pictish kings 761–839', 81–2.

<sup>153</sup> Broun's suggestion (*ibid.*, 82) that Drest son of Talorgen was the son of Talorgen son of Onuist is unlikely (see above 16 n.56).

<sup>154</sup> The appearance of an obit for a *Dubtholargg* (perhaps Talorgen son of Onuist), 'king of the Picts this side of *Monoth*', in AU 782.1, and the references to kings of Dál Riata in AU 778.7 (AClon 769.4, and the *Annals of the Four Masters*, ed. and trans.

more concentrated, resting with members of the dynasty of Onuist son of Uurguist, but some checks on its power still existed.

What is striking is that this change took place at the same time as the appearance of exceptions to the previous name-pattern.<sup>155</sup> The breakdown of the name-system which had distinguished between the royal names of kings and their fathers with non-royal names is clear from the late 770s or early 780s, when there is Drest son of Talorgen, Talorgen son of Drusten, and Talorgen son of Onuist, all of whose fathers had names previously used for kings. The first instance of this may in fact be earlier, since Ciniod son of Uuredech (763–75) had a patronymic which is found as a royal name in the prehistoric section (for Uuradech Uecla). The most likely explanation for the breakdown of the system is that sons could succeed their fathers, which would make the prohibition on fathers having royal names impossible to sustain. This, therefore, pushes the change to the succession system back to the reign of Onuist son of Uurguist (729/32–61) or earlier, since Ciniod son of Uuredech, and at least some of the kings of the late 770s and 780s, would have been born by 761.

Indeed, it is likely that the succession-system changed under Onuist himself, perhaps taking advantage of the disruption of the 720s. Up to the reign of Nectan son of Derelei (707–24, 729–32) no sons had succeeded their fathers, and the nomenclature rule seems to have been adhered to, but the conflicts of the 720s, involving Nectan son of Derelei, Onuist son of Uurguist, Drest and Elpin may have reduced the number of potential royal candidates and broken pre-existing power structures, allowing space for radical developments in the kingship. It is possible that either one or both of Drest and Elpin had fathers with royal names, since no sources give their patronymics, but there is no evidence for us to judge.<sup>156</sup> Onuist son of Uurguist himself flouted the nomenclature rule, since his name is not found earlier in the Pictish king-list.<sup>157</sup> However, he had two brothers, Bredei and Talorgen, and a son, Bredei (militarily active in the 730s), all with royal names. It is clear that the name pattern was being neglected

---

John O'Donovan, *Annála Ríoghachta Éireann: Annals of the Kingdom of Ireland, by the Four Masters, from the Earliest Period to the Year 1616*, 7 vols [Dublin, 1856] [hereafter AFM], 771.18), AU 781.3 (AClon 778.2, AFM 776.7), and AU 792.4 (AFM 787.4) makes it likely that in the 780s the Picts were divided and unable to retain control over Dál Riata.

<sup>155</sup> These exceptions were noticed by Miller, 'The last century', 53.

<sup>156</sup> It is possible that their patronymics were omitted to disguise their unusual parentage. However, there are other kings without patronymics in the section of the lists before Bredei son of Mailcon, and a king called Bred is recorded as ruling for one year before Cináed son of Alpín in SL (SB adds 'son of Ferat', possibly in a late addition), so such an argument is questionable.

<sup>157</sup> His father's name, Uurguist, is found as a king in the prehistoric section added 842x76 to SL (see SL1, ed. Anderson, *Kings*, 245) so his father's name could also have been viewed by some as royal, if this was created after Onuist's succession.

at some point here: either in giving Onuist a non-royal name while his brothers had royal names, or, if Onuist was an unattested royal name, in his decision to give his son a royal name (presumably in the 710s or earlier). Either Onuist himself should never have been king, or he had broken the rules by giving his son a royal name when he himself could become king.<sup>158</sup>

The former proposition is supported by Woolf's re-interpretation of the civil war in 728–9, that Nectan re-gained the kingship in 729 through Onuist's military victories.<sup>159</sup> It may have been the case that in 729 Onuist preferred the royal claim of Nectan, but acted as the power behind the throne. When Nectan died in 732 Onuist may have felt able to take the kingship, despite having no legitimate claim (although his brothers may have, if they had a different mother from Onuist).<sup>160</sup> As part of his effort to legitimise his rule, it would have been necessary to attack and disregard the name-system. It is possible that he was also prepared to change succession practice so that a son of a king could become king, thus allowing his son Bredei (and probably Talorgen, if the later king of that name was his son) to become king. Bredei's death in 736 would not have changed this, if Talorgen son of Onuist and later kings were from the same kindred; their legitimacy would have been dependent on Onuist's to some extent.

It is likely, therefore, that it was the period of the reign of Onuist son of Uurguist which saw a decisive change in the pattern of Pictish succession: sons could succeed fathers, and the name system became redundant. However, significant elements of previous practice continued; brothers were still preferred,<sup>161</sup> sons did not succeed their fathers immediately, and people seemingly unconnected to Onuist's dynasty could also become king.<sup>162</sup> This may have been in spite of a policy

---

<sup>158</sup> See Woolf, 'Onuist son of Uurguist', 36, for the idea that Onuist 'had, if any, only a somewhat distant claim to the throne'. It is possible that Onuist was completely outside of the royal kin-group, since there is no evidence that the royal name system was adhered to elsewhere in society.

<sup>159</sup> Alex Woolf, 'AU 729.2 and the last years of Nechtan mac Der-Ilei', *SHR* 85 (2006), 131–4.

<sup>160</sup> He was, however, clearly in a powerful enough position in 728 and 729 to challenge Pictish kings, indicating that he already had a high status, and considerable resources. An alternative idea (suggested to me by Dauvit Broun), that Onuist had a different mother than his two brothers, makes it possible (under a matrilinear system) that Onuist's wife would have been a member of the royal dynasty and provided the legitimacy for giving his son the name Bredei. Unfortunately our understanding of who was eligible for the kingship is likely to remain very vague, due to the limited evidence.

<sup>161</sup> Onuist was succeeded by his brother Bredei (761–3), Castantin son of Uurguist (c.788–820) by Unuist son of Uurguist (820–34), and Cináed son of Alpín (842/3–58) by Domnall son of Alpín (858–62).

<sup>162</sup> These seemingly unconnected kings could have been from other Pictish kindreds than Onuist's or from the same kindred, but not closely related by patrilineal descent.

of eliminating rival claimants and sub-kings.<sup>163</sup> It is notable that there was a considerable period of time after Onuist's reign before sons of previous kings succeeded, with the first probably being Talorgen son of Onuist (779–82?) and Talorgen son of Drusten (780–4, 782–4?), perhaps a son of the King Drest who ruled in the 720s. This delay could reflect some resistance to father-to-son succession, but this is not certain and the correspondence in time with the change in the name-pattern makes it likely that the two new practices were closely connected, being part of the same reforms of Onuist's reign.

Such alterations in succession practice could have been accompanied by other changes in Pictish political structure, and perhaps are connected in some way to developments in archaeological patterns, whereby hillforts were abandoned, and palaces as well as ecclesiastical sculpture and patronage were developed as expressions of elite power and rule.<sup>164</sup> However, the continuation of the Pictish king-lists, as well as the use of the titles *rex Pictorum* and *rex Fortrenn* in this period indicate that many of the pre-existing ideological concepts surrounding the kingship were retained or adapted.<sup>165</sup>

The modified succession practice established in Onuist's reign was continued by Cináed son of Alpín and his successors as kings of Alba, but with more success in excluding people from outside his kin-group from the kingship.<sup>166</sup> From Cináed's reign (842/3–58) until the mid-eleventh century, the only person who had no perceivable link with the descendants of Alpín was Giric son of Dúngal, who may have ruled with Eochaid son of Rhun (878–89).<sup>167</sup> It would seem that there was still a strong desire to prevent a single line of descent from dominating the kingship, since a son did not immediately succeed his father. The system adopted – alternation of the kingship between two branches descended from sons of Cináed son of Alpín – probably was a factor in enabling the exclusion of

<sup>163</sup> See Woolf, 'The Verturian hegemony', 111, and *idem*, 'Onuist son of Uurguist', for a discussion of Onuist's reign.

<sup>164</sup> See Stephen T. Driscoll, 'Political discourse and the growth of Christian ceremonialism in Pictland: the place of the St Andrews Sarcophagus', in *The St Andrews Sarcophagus*, ed. Foster, 168–78; Woolf, 'The Verturian hegemony', 106–12, 110–11.

<sup>165</sup> See above, 8–12, 39–40.

<sup>166</sup> See Alex Woolf, 'The "Moray question" and the kingship of Alba in the tenth and eleventh centuries', *SHR* 79 (2000), 145–64, esp. 146 (for a family tree) and 152–4 and Alex Woolf, *From Pictland to Alba, 789–1070* (Edinburgh, 2007), 87–271 for a detailed account of the period. No son immediately succeeded his father in either the kingship of the Picts, or in the successor-kingship of Alba until the thirteenth century, although the alternation system ended in the eleventh century.

<sup>167</sup> Eochaid's succession may reflect a willingness to prevent the succession of a king's son, and to allow succession through the female line, as he was the sister's son of the previous king and the grandson through his mother of Cináed son of Alpín, but it does not represent a return to the old name system.



other claimants and a greater concentration of power in the overall polity. However, the only significant ideological conceptual development that was necessary for this was the theory that only a descendant of Cináed mac Alpín was a legitimate claimant to the kingship.<sup>168</sup>

The succession system, therefore, was significant, both reflecting and moulding the Pictish polity. From a kingship shared by members of a large royal dynasty, in which sons could not succeed their fathers, and which employed a distinctive naming practice, it developed into a kingship in which sons could succeed, albeit not immediately, and in which royal power had become concentrated in the hands of a small group. Since this pattern was largely maintained by the dynasty of Cináed son of Alpín after the end of Pictish political identity, succession practice provides one area where there is significant evidence for continuity from the over-kingship of the Picts to that of Alba. Overall, then, the succession to the Pictish over-kingship should not be viewed as an aberration from typical western European practice; instead it should be perceived as an unusual but not unparalleled system, subject to the same continually changing practical and ideological forces which shaped other early medieval kingships.<sup>169</sup>

DR NICHOLAS EVANS IS THE HUNTER-MARSHALL RESEARCH FELLOW IN THE UNIVERSITY OF GLASGOW.

---

<sup>168</sup> This is not to exclude the likelihood that the dynasty was also promoted using other arguments.

<sup>169</sup> This article was researched while I was at the Dublin Institute for Advanced Studies and the University of Glasgow, so I would like to thank the staff in both those institutions for their assistance. I am very grateful for the useful comments offered by many people on the subject after papers given at the Leeds International Medieval Congress, the 'Fresh Pict' conference held at Aberdeen in 2006, and a Medieval Scottish Studies Seminar in Glasgow in April 2007, for the assistance offered by Stuart Airlie, John Koch, Graham Isaac, and Sarah Thomas, as well as to Alex Woolf, for allowing me to see a draft of *From Pictland to Alba, 789–1070*. However, all remaining errors in this are my own.