



THE UNIVERSITY *of* EDINBURGH

Edinburgh Research Explorer

No evidence for an intragenomic arms race under paternal genome elimination in *Planococcus mealybugs*

Citation for published version:

García de la Fíliá, A, Fenn-Moltu, G & Ross, L 2019, 'No evidence for an intragenomic arms race under paternal genome elimination in *Planococcus mealybugs*', *Journal of Evolutionary Biology*.
<https://doi.org/10.1111/jeb.13431>

Digital Object Identifier (DOI):

[10.1111/jeb.13431](https://doi.org/10.1111/jeb.13431)

Link:

[Link to publication record in Edinburgh Research Explorer](#)

Document Version:

Peer reviewed version

Published In:

Journal of Evolutionary Biology

Publisher Rights Statement:

This article has been accepted for publication and undergone full peer review but has not been through the copyediting, typesetting, pagination and proofreading process, which may lead to differences between this version and the Version of Record. Please cite this article as doi: 10.1111/jeb.13431 This article is protected by copyright. All rights reserved.

General rights

Copyright for the publications made accessible via the Edinburgh Research Explorer is retained by the author(s) and / or other copyright owners and it is a condition of accessing these publications that users recognise and abide by the legal requirements associated with these rights.

Take down policy

The University of Edinburgh has made every reasonable effort to ensure that Edinburgh Research Explorer content complies with UK legislation. If you believe that the public display of this file breaches copyright please contact openaccess@ed.ac.uk providing details, and we will remove access to the work immediately and investigate your claim.



MR. ANDRÉS GARCÍA DE LA FILIA (Orcid ID : 0000-0002-6010-9441)

Article type : Research Papers

No evidence for an intragenomic arms race under paternal genome elimination in *Planococcus mealybugs*

Andrés G. de la Filia¹, Gyda Fenn-Moltu¹, Laura Ross¹ □

1. School of Biological Sciences, Institute of Evolutionary Biology, University of Edinburgh, Edinburgh, EH9 3FL, UK □

Acknowledgements □

The authors would like to thank Prof. José Carlos Franco (Universidade Técnica de Lisboa) and Prof. Zvi Mendel (Volcani Center) for providing us with the mealybug cultures and Prof. Jocelyn Millar (University of California Riverside) for providing the synthetic sex pheromones used in this study. AGF was funded by the Darwin Trust of Edinburgh. LR was funded by the Natural Environment Research Council (Ne/K009516/1).

Corresponding author mail id: a.gdelafilia@ed.ac.uk

No evidence for an intragenomic arms race under paternal genome elimination in *Planococcus mealybugs*

This article has been accepted for publication and undergone full peer review but has not been through the copyediting, typesetting, pagination and proofreading process, which may lead to differences between this version and the Version of Record. Please cite this article as doi: 10.1111/jeb.13431

This article is protected by copyright. All rights reserved.

Abstract

Genomic conflicts arising during reproduction might play an important role in shaping the striking diversity of reproductive strategies across life. Among these is paternal genome elimination (PGE), a form of haplodiploidy which has independently evolved several times in arthropods. PGE males are diploid but transmit maternally-inherited chromosomes only, while paternal homologues are excluded from sperm. Mothers thereby effectively monopolize the parentage of sons, at the cost of the father's reproductive success. This creates striking conflict between the sexes that could result in a coevolutionary arms race between paternal and maternal genomes over gene transmission, yet empirical evidence that such an arms race indeed takes place under PGE is scarce. This study addresses this by testing if PGE is complete when paternal genotypes are exposed to divergent maternal backgrounds in intraspecific and hybrid crosses of the citrus mealybug, *Planococcus citri*, and the closely related *P. ficus*. We determined whether males can transmit genetic information through their sons by tracking inheritance of two traits in a three-generation pedigree: microsatellite markers and sex-specific pheromone preferences. Our results suggest leakages of single paternal chromosomes through males occurring at a low frequency, but we find no evidence for transmission of paternal pheromone preferences from fathers to sons. The absence of differences between hybrid and intraspecific crosses in leakage rate of paternal alleles suggests that a coevolutionary arms race cannot be demonstrated on this evolutionary timescale, but we conclude that there is scope for intragenomic conflict between parental genomes in mealybugs. Finally, we discuss how these paternal escapes can occur and what these findings may reveal about the evolutionary dynamics of this bizarre genetic system.

Keywords: Intragenomic conflict, paternal genome elimination, mealybugs, meiotic drive

Introduction

Sexual reproduction is extremely variable, a result of the extraordinary diversity of genetic and reproductive systems that have evolved across the tree of life (Bachtrog *et al.*, 2014). The sources of this variability remain elusive, so understanding which forces and processes drive transitions between genetic systems and the emergence of complex modes of reproduction is an important challenge for modern evolutionary biologists. One evolutionary force commonly invoked is intragenomic conflict (Burt & Trivers, 2006; Ross *et al.*, 2010a; Werren, 2011; Normark & Ross, 2014; Úbeda *et al.*, 2015; Gardner & Úbeda, 2017). Such conflict occurs when different genetic entities that coexist within individuals (e.g. nuclear versus cytoplasmic genes, autosomes versus sex chromosomes, mobile elements) disagree over transmission to future generations (Gardner & Úbeda, 2017). In sexually reproducing eukaryotes, an important potential source of intragenomic conflict is the parental origin of the haploid copies that make up a diploid genome, as they are inherited from two different individuals with an evolutionary interest in maximising the transmission of their own genes (Normark & Ross, 2014). Many alternative genetic systems emerge when mothers or fathers gain a transmission advantage by enhancing the transmission of the copies they transmit to the offspring at the expense of their partners': for example, arrhenotoky (i.e. true haplodiploidy), under which mothers monopolize parentage of sons, or androgenesis, where fathers are the sole contributors of genetic material to both offspring sexes (Normark, 2006; Schwander & Oldroyd, 2016). These systems are dramatic manifestations of intragenomic conflict, as Mendelian laws of fair inheritance are thwarted and genes undergo different fates depending on the sex of the individual they find themselves in.

One of the genetic systems where such conflict is particularly apparent is paternal genome elimination (PGE). PGE is a form of haplodiploid reproduction in which males develop from fertilized eggs (in contrast to arrhenotoky), but eventually lose their paternally-inherited chromosomes and only transmit the maternal homologs to the offspring (Normark,

2003; Burt & Trivers, 2006). PGE has a rich evolutionary history: it has independently evolved at least six times in insects and once in mites (Burt & Trivers, 2006; Gardner & Ross, 2014; de la Filia *et al.*, 2015; Blackmon *et al.*, 2015). Although males of all species with PGE lose their paternal chromosomes, timing of loss varies between taxa. In some groups, paternal chromosomes are lost early in development (embryonic PGE); in others, males remain (mostly or completely) somatically diploid and elimination of paternal chromosomes is delayed until spermatogenesis, when they fail to be incorporated into active sperm (germline PGE). Moreover, some germline PGE taxa shut down expression of paternal chromosomes, which are highly condensed and therefore transcriptionally inactivated (Gardner & Ross, 2014).

When considering transmission patterns of genes under PGE, it is clear why it leads to intragenomic conflict between maternal and paternal genomes: maternally-inherited alleles enjoy a transmission advantage through sons at the expense of paternally-inherited alleles, directly reflecting a conflict between male and female partners in which the latter have gained the upper hand (Bull, 1979). Such conflict is likely to unchain an evolutionary arms race between both sexes and, consequently, maternally- and paternally-inherited alleles during spermatogenesis (Herrick & Seger, 1999; Ross *et al.*, 2010a). Once PGE has arisen, there is strong selection on males to evolve adaptations that will allow (all or a fraction of) their alleles to escape elimination when in sons. However, the success of such paternal adaptations is predicted to be short lived, as they will trigger the evolution of maternal responses to override paternal resistance and maintain complete transmission advantage of maternally-inherited alleles (Herrick & Seger, 1999). Since germline PGE is a type of whole-genome meiotic drive in which the entire maternal chromosomal complement drives, the dynamics of this arms race in this system are similar to other drive-suppression systems (Burt & Trivers, 2006; Lenormand *et al.*, 2016; Lindholm *et al.*, 2016). Well-known examples of drivers include sex-linked alleles (Tao *et al.* 2007a; Tao *et al.* 2007b; Phadnis & This article is protected by copyright. All rights reserved.

Orr 2009), autosomal haplotypes (Schimenti 2000; Larracuente & Presgraves 2012), centromeric elements (Fishman & Willis 2005; Chmátal *et al.* 2014) and supernumerary chromosomes (Camacho *et al.* 2000). In drive-suppression systems, when one of these genetic entities drives (i.e. develops the ability to manipulate meiotic processes to increase its presence in gametes at the expense of the rest of the genome), suppressors emerge to restore transmission symmetry.

To date, no empirical validation in support of these evolutionary scenarios under PGE is available. There is very scarce evidence of paternal escapes under PGE, which have only been conclusively shown in a single species, the human louse *Pediculus humanus* (Phthiraptera: Pediculidae) (McMeniman & Barker, 2005; de la Filia *et al.*, 2017). Direct empirical evidence for a putative arms race is completely lacking. The historical dynamics of an arms race between maternal and paternal alleles can be revealed by assessing how complete PGE is in the hybrid offspring of crosses between closely related species. For example, cryptic sex ratio distorters often reappear in hybrids, free from the constraint imposed by fixed suppressors that have evolved in their original population or species to contain these meiotic drivers (Frank, 1991; Hurst & Pomiankowski, 1991; Hurst & Werren, 2001; Tao *et al.*, 2007b). Likewise, paternal adaptations against PGE could be unmasked when exposed to divergent maternal backgrounds. The mealybug *Planococcus citri* (Hemiptera:Pseudococcidae) is a particularly-well suited system for such an approach. In *Planococcus* mealybugs, paternal chromosomes are silenced during blastula stage in embryos that develop as males, although the sex determination signal remains unclear (Bongiorni *et al.*, 2001). *P. citri* has emerged in recent years as a model organism for germline PGE (Brown & Nur, 1964; Bongiorni & Pranter, 2003; Khosla *et al.*, 2006; Ross *et al.*, 2010a; Pranter & Bongiorni, 2012) and hybridizes readily with other closely related species. A recent study by Kol-Maimon *et al.* (2014a) using hybrid crosses between *P. citri* and *P. ficus* found instances of occasional transmission of the paternal ribosomal ITS2

Accepted Article

region through hybrid males, but the presence of hybrid genotypes in their parental *P. citri* population—a result of hybridization in the wild (Kol-Maimon *et al.*, 2014b)—and differential amplification in males and females complicate interpretation of their findings. Conclusive evidence requires a larger number of independent genetic markers that allow determining species identity of parental genomes unambiguously. Microsatellite loci, now available as a diagnostic tool to distinguish between these two species (Martins *et al.*, 2012), are a more suitable tool to confirm whether victory of maternal genomes is complete, or paternal genomes have not yet had their final say.

Here, we aim to test for the existence of an evolutionary arms race between parental genomes in PGE species using a three-generation family study with wild-derived laboratory lines of *P. citri* and *P. ficus* to evaluate two key predictions: 1) that paternally-derived chromosomes can escape elimination in males when exposed to a maternal genomic background they have not coevolved with and 2) that these escapes happen at a higher rate in hybrid males produced in interspecific crosses between *P. citri* and *P. ficus*, than in males produced in intraspecific crosses. We use two strategies to detect patrilineal transmission of genetic material: a panel of polymorphic microsatellite markers (Martins *et al.*, 2012) and male response to sex pheromones—a traceable species-specific phenotype which allows discriminating parental species (Kol-Maimon *et al.*, 2014a, 2014b), as morphological differences are extremely difficult to observe. Our results suggest sporadic instances of patrilineal inheritance of microsatellite markers in both hybrid and intraspecific crosses at a similar frequency, but no transmission of pheromone preferences. We therefore conclude that there is scope for conflict between parental genomes under PGE due to incomplete effectiveness of the mechanism of paternal chromosome exclusion during spermatogenesis, but no clear indication of a recent coevolutionary arms race between parental genomes in these mealybug species.

Methods

Experimental populations and laboratory rearing

All the experimental crosses in this study were conducted between individuals from three *P. citri* and two *P. ficus* isofemale lines originated from natural populations and reared in the laboratory under a sib-mating regime. The three *P. citri* lines had undergone at least 15 generations of sib-mating prior to these experiments. Two lines, PC_WYE3-2 and PC_BGOX3, derived from populations collected from English greenhouses and the third line, PC_CP1-2, originated from Israel. Both *P. ficus* lines (PF_1-1 and PF_3-1) were derived from Israeli populations and had undergone >8 generations of sib-mating. Mealybug lines were reared on sprouted potatoes placed on tissue paper in sealed containers (boxes or glass/plastic stock bottles) at >50% relative humidity and temperatures of 24-26°C (for *P. citri*) or 26-29°C (for *P. ficus*). To minimize chances of cross contamination, both species were kept in separate rooms. Experimental crosses were kept at 25°C and a 16h-light/8h-dark photoperiod without humidity control.

Experimental crosses

The same experimental cross design was followed in all the experiments in this study and is schematized in Fig. 1A. Males and females from different parental F0 lines were isolated and mated to produce F1 cohorts with divergent maternal and paternal haploid genomes. For hybrid crosses, we set 4 biological replicates (i.e. mating pairs) of all possible reciprocal combinations between two *P. citri* lines (PC_WYE3-2 and PC_CP1-2) and the *P. ficus* lines (PF_1-1 and PF_3-1) and raised the F1 hybrid broods until adulthood. However, we found extremely high levels of hybrid male mortality when crossing *P. ficus* females and *P. citri* males during early larval stages, so that all hybrid males from this genotype (FC hybrids) failed to reach reproductive maturity. This high mortality occurred in all crosses with

P. ficus mothers, regardless of parental lines; therefore, we could only test allele transmission in hybrid males from *P. citri* mothers (CF hybrids). When possible, we mated 4 CF hybrid males from each F1 brood to a female from the second line of the maternal species (*P. citri*) to produce F2 offspring (Fig. 1B). A simplification of this scheme was used to analyse transmission of sex pheromone responses by hybrid F1 males (see below). For intraspecific crosses, we set 3 biological replicates of all possible reciprocal combinations between the three *P. citri* lines (Fig. 1C), raised the F1 broods until adulthood and mated F1 males to females from the experimental line that had not been used in the F0 cross.

For all experimental crosses, virgin females were isolated after becoming sexually differentiated (3rd instar) and kept in separate containers until reproductive maturity (>35-day old). Males were isolated after pupation and kept in clear glass shell vials until emergence of sexually mature adults. Hybrid crosses took place in 6cm-diameter glass Petri dishes with the aid of synthetic pheromones from the paternal species (see below) and occurrence of mating was visually monitored. After mating concluded, the male-female pair was transferred to shell vials containing a single potato sprout and sealed with cotton wool. For intraspecific *P. citri* crosses, male-female adult pairs were placed directly into shell vials. In both cases, the mating pair was kept in the vial for 3-5 days until egg-laying was observed. Then, males were immediately frozen at -20°C for genotyping and females were transferred to a new rearing container and left to lay eggs for at least 10 days or until death, after which they were removed and frozen at -20° after removal of their bottom half (to avoid genotyping of remaining unlaidd eggs). F2 individuals were raised until they reached 2nd larval instar and either genotyped directly or after -20° freezing.

Microsatellite genotyping

Total genomic DNA from F0, F1 and F2 individuals from experimental crosses was extracted using prepGEM Insect kit (ZyGEM, New Zealand) following the manufacturer's instructions but reducing the reaction volume by 50%. F0 parents and F1 fathers were genotyped as described above. Females mated to F1 males were also genotyped when needed to resolve ambiguous genotypes. In rare cases where individuals exhibiting genotypes incompatible with parental alleles were observed (10 hybrid crosses and 2 intraspecific crosses), accidental contamination was assumed and affected crosses were discarded.

For genotyping, microsatellite primers for PCR amplification were obtained from Martins *et al.* (2012). A panel of 6 multiplexed loci (Pci-7, Pci-16, Pci-17, Pci-21, Pci-22 and Pci-24) was used in hybrid crosses. For intraspecific *P. citri* crosses, the informative locus panel consisted on the three loci showing intraspecific variability (Pci-7, Pci-16 and Pci-17) and two additional monomorphic loci (Pci-21, Pci-22) to help diagnosing genotyping success for each reaction (Table S1). Linkage relationships between these loci are unknown. PCR amplification of microsatellite loci was performed using Type-it Microsatellite PCR kit (QIAGEN, The Netherlands) in a 10 μ L reaction volume containing 1 μ L of prepGEM reaction product, 5 μ L of 2x Master Mix, 0.25 μ M of the reverse primer and 0.25 μ M of each 5' fluorescently-tagged forward primer. PCR reactions were performed under the following conditions: initial denaturation at 95°C for 5 min, 32 cycles of denaturation at 95°C for 30s, annealing at 55°C for 90s and extension at 72°C for 30s and a final extension step at 60°C for 30min. 1 μ L of PCR product was sent to Edinburgh Genomics for microsatellite genotyping on the ABI 3730 DNA Analyzer system (ThermoFisher Scientific, United States of America) with LIZ 500 as size standard. Microsatellite peaks were scored with Microsatellite Plugin implemented in Geneious 8.1.3 (Biomatters Ltd., New Zealand) and corrected manually.

Allele transmission ratios

For each F2 family and locus, transmission ratios of F1 males were calculated as the proportion of maternally-derived alleles they transmitted to their offspring: i.e. number of occurrences in F2 families of their maternally-inherited alleles divided by total number of F2 genotypes. A transmission ratio of 1 is indicative of complete PGE, while 0.5 denotes Mendelian transmission. For each ratio, an exact binomial test to detect significant deviations from Mendelian expectations was performed in R 3.2.4 (R Development Core Team). To correct for multiple testing, adjusted q-values were computed using the one-stage false discovery rate approach with FDR<1% as significance threshold. When possible, transmission ratios for F1 females were also estimated to confirm Mendelian transmission by calculating the proportion of one of the two alleles (chosen at random) at heterozygous maternal loci passed on to the F2 offspring.

Sex pheromone response analysis

Interspecific crosses to produce F1 hybrid males were conducted as described above, but using a single line from each species only (PC_WYE3-2 and PF_1-1). Due to high mortality of F1 hybrid males with *P. ficus* mothers (FC hybrids), only males from PC_WYE3-2 mothers and PF_1-1 fathers (CF hybrids) could be used to produce F2 broods. 10 F0 interspecific crosses were carried out to produce F1 hybrid broods, from which 20-30 males were isolated and mated to a female from the maternal line (PC_WYE3-2) to produce F2s (CF x C), which were raised until adulthood. Intraspecific crosses to produce broods of pure *P. citri* and *P. ficus* males were conducted in an identical way.

Male response trials to both *P. citri* and *P. ficus* sex pheromones were conducted for F0 and F2 males. Synthetic pheromones were provided by Prof. Jocelyn Millar (University of California Riverside) and diluted in pure ethanol to a concentration of 10ng/μl. The synthetic *P. citri* pheromone (C-phe) used in this experiment is the pure RR enantiomer of the single component (S+)-cis-(1R)-3-isopropenyl-2,2-dimethylcyclobutanemethanol acetate (Bierl-Leonhardt et al., 1981), while as *P. ficus* pheromone (F-phe) we used the racemic component (S)-lavandulyl senecioate (Hinkens et al., 2001).

Males were isolated after pupation and kept in shell vials until adulthood. Trials were conducted 24h after adults had emerged from their cocoons in 6cm-diameter glass Petri dish arenas. These arenas contained two 1cm² filter paper squares set on opposite sides of the plate, which were randomly infused with either 10ng of pheromone or 1μl of pure ethanol (as control). Each male was placed in the centre of the arena and its responses to both pheromone and control papers were recorded for 15min. Time of contact with pheromone and control was defined as the number of seconds during which the male had any part of his body touching each filter paper. After 15min, the male was taken back to the shell vial for 5min and then transferred to a second area containing the other pheromone. Time to first contact with pheromone (number of seconds until a male arrived at the pheromone paper for the first time since start of trial) was also recorded. Trials were blind regarding identity and genotype of the males and the order of exposure to both pheromones was assigned randomly for each male.

Analysis of pheromone response data was performed in R 3.2.4 (R Development Core Team). To analyse total contact times, we corrected for time spent on the control paper during trials by subtracting the number of seconds males were in contact with the control from the number of seconds in contact with the pheromone in each trial. Negative values of

Accepted Article

this corrected measurement (i.e. when a male spent more time on the control paper than the pheromone) were given a value of 0, as we considered that these males did not show a true pheromone response. We fitted a series of mixed models using the 'lme4' R package (Bates *et al.* 2015) to test whether patterns of pheromone response differ between the three groups of males included in this study (*P. citri*, *P. ficus* and CF x C F2 offspring). First, we fitted a binomial GLMM to test for differences in the frequency of responding males to both pheromones across genotypes. Then, we fitted two linear mixed models to further explore two additional aspects of behaviour of responding males: intensity of attraction (total time in contact with pheromones) and speed of response (time to first contact). In all three models, we included pheromone, genotype and their interaction as fixed effects. We also included order of exposure to both pheromones as an additional fixed effect and male ID as a random effect. We used likelihood ratio tests to assess significance of fixed effects and Tukey *post hoc* comparisons to test for differences between pairs of genotypes using the 'multcomp' R package (Hothorn *et al.* 2008).

Species confirmation and primer mapping

In order to confirm species identity of the PC_WYE3-2 and PF_1-1 lines used in the sex pheromone response experiment, we retrieved the 28S-D2, ITS2, COI-region 2 and COI-LCO sequences from the genome assemblies generated from both lines by our research group (PCITRI.V1 and PFICUS.V0, publicly available in <http://mealybase.org>). To obtain these sequences, we blasted the *P. citri* sequences for those regions obtained by Malausa *et al.* (2011) against both assemblies using the BLAST tool in <http://mealybug.org> with default settings. The best matches from each species were then compared to GenBank sequences using the NCBI BLAST tool (<http://blast.ncbi.nlm.nih.gov>). To reveal the extent of genome coverage of our microsatellite panel, we mapped all loci against both genome assemblies. All forward and reverse primer sequences were blasted against PCITRI.V1 and PFICUS.V0 using the BLAST tool in mealybug.org with default settings.

This article is protected by copyright. All rights reserved.

Results

Microsatellite panel optimization

We initially tested Pci-6, Pci-7, Pci-14, Pci-16, Pci-17, Pci-21, Pci-22 and Pci-24 from Martins *et al.* (2012) for amplification in all experimental lines. All markers successfully amplified in the three *P. citri* lines, while Pci-6 and Pci-14 failed to amplify in *P. ficus*. Since these two loci were found to be monomorphic in our *P. citri* lines, they were discarded for further genotyping.

A list of the alleles amplified in both species is provided in Table S1. BLAST searches revealed that all markers are located within different scaffolds in both genome assemblies. Pci-16, Pci-17, Pci-21, Pci-22 and Pci-24 were found to be optimal diagnostic markers for hybrid crosses due to the presence of species-specific alleles. Pci-7 was also included in the genotyping panel for hybrid crosses due to its high allelic richness, even when alleles were shared between both species. For intraspecific crosses, only Pci-7, Pci-16 and Pci-17 were found to be polymorphic within the *P. citri* lines examined in this study.

Allele transmission in hybrid crosses

In order to test allele transmission in hybrid males, we initially aimed to conduct all reciprocal crosses between both *P. citri* and *P. ficus* lines. However, we found extreme sex-specific mortality in crosses with *P. ficus* mothers and *P. citri* fathers: hybrid males from these crosses (FC hybrids) consistently failed to reach adulthood, regardless of parental lines or raising conditions. We set at least 4 replicates of each FC cross from all possible combinations (PF_1-1 and PF_3-1 mothers x PC_WYE3-2 and PC_CP1-2 fathers) and only obtained three adult males, none of which managed to successfully mate to produce F2 broods. Therefore, all hybrid males that survived to adulthood and fathered F2 broods in this

study derive from CF crosses (PC_WYE3-2 and PC_CP1-2 mothers x PF_1-1 and PF_3-1 fathers).

All F0 *P. citri* mothers and *P. ficus* fathers were genotyped to confirm the presence of alleles specific to both species at the diagnostic markers (Pci-16, Pci-17, Pci-21, Pci-22 and Pci-24) and to determine their Pci-7 genotypes. All F1 broods were genotyped after mating to confirm expected genotypes in case of parental homozygosity and to determine their genotypes at those loci they were heterozygous for in one or both F0 parents. In all cases of parental heterozygosity, F1 genotypes adjusted to expected patterns of PGE transmission: heterozygous F0 males transmitted one allele only (that of maternal origin) to all genotyped F1 males, while heterozygous F0 females transmitted both. Rarely (10 hybrid crosses), genotyping of F1 hybrid males unexpectedly revealed *P. citri* alleles only. This was interpreted as instances of females having mated prior to isolation or accidental contamination of F1 hybrid bottles with males from the maternal species and led to discarding of whole affected broods.

From each F1 brood, 4 hybrid males were mated to father 4 F2 families each (with two exceptions: 5 males for W3-1 and 3 males from C3-4), yielding 64 F2 families (Fig. 1B, Appendix S2). We found that 63/64 F1 hybrid fathers showed complete PGE (Fig. 2A): they only transmitted maternally-derived alleles to the F2 at all loci and no grandpaternal (i.e. *P. ficus*) alleles were found in the genepool of the F2 broods they fathered. The only exception was W1-4_1 (Table S2): one of the F2 individuals sired by this male was found to have a grandpaternal *P. ficus* allele at two loci (Pci-17 and Pci-22). The other loci in this individual showed maternally-inherited F1 alleles only, as expected under PGE. The remaining 11 genotyped individuals fathered by W1-4_1 received his maternal alleles only at these loci.

In total, 356 transmission ratios across all males and loci were estimated (at least 5 for each male at the 5 inter-species diagnostic loci and an additional one at Pci-7 for 36 males which were also heterozygous at that locus) (Appendix S3). 354 of these ratios, all except for these two exceptions mentioned before, had a value of 1, indicating complete PGE. Assuming equal probability of transmission of paternal alleles across all loci, we obtained an estimation of frequency of paternal escapes of 0.0007-0.0201 (95% CI). Even though we did not genotype females mated to F1, it was also possible to estimate maternal transmission ratios when a *P. citri* allele different from the one transmitted by the F1 father was observed in F2 families. These cases were indicative of maternal heterozygosity and allowed us to determine whether F1 females transmitted alleles in a Mendelian way, as expected in a PGE system. We could thus estimate 27 transmission ratios for F1 females, none of which deviated significantly from Mendelian expectations (exact binomial test, q -value > 0.01).

Allele transmission in intraspecific crosses

For intraspecific crosses, three biological replicates were set for each possible cross. However, only one replicate with PC_WYE3-2 mothers and PC_BGOX-3 father could be successfully raised into adulthood. For each F1 brood, between 3 and 5 males were mated to produce F2 broods. In total, we obtained transmission patterns for 65 F1 males at one informative locus at least (Fig. 2B, Appendix S4). Of these, 3 F1 males showed allele transmission patterns consistent with incomplete paternal genome elimination (Table S2). F2 genotypes were consistent with BW_2_3 and BC1_3 transmitting a paternal allele once, both at the Pci-7 locus, and CB_3_1 passing on paternal alleles to a same F2 individual at the Pci-7 and Pci-17 loci. We validated all these exceptions by re-genotyping individuals showing escaped alleles. However, we could not genotype the PC_WYE3-2 female that was mated to CB3_1, which opens the possibility that the seemingly paternal allele that would

Accepted Article

have been transmitted by this male to one of their offspring actually derives from the F1 mother. Since the hypothesis of Mendelian inheritance for the putatively escaped allele at that locus cannot be rejected (11 F2 individuals, q -value=0.013), this escape cannot be unambiguously confirmed.

Overall, 144/148 transmission ratios across all males and loci were consistent with complete PGE (Appendix S5). As in hybrid crosses, we also estimated 21 transmission ratios for F1 mothers, none of which significantly departed from Mendelian expectations (q -value>0.01). The frequency of paternal escapes in intraspecific crosses, again assuming equal rates across all three loci, was estimated to be 0.0074-0.0678 (95% CI). This value was not significantly different to the estimation obtained for hybrid crosses (Pearson's χ^2 test with Monte Carlo simulation, p =0.065).

Combining data from hybrid and intraspecific males, we obtained a common estimation of frequency of paternal escapes of 0.0044-0.0257 (95% CI). In total, 4 of 1,548 genotyped F2 individuals between hybrid and intraspecific crosses exhibited grandpaternal alleles at one or two loci. In all these escapes, it is unclear whether both parental copies were incorporated into sperm or whether the escaped paternal allele replaced the maternal copy. The allele transmitted to the F2 offspring by their mother and the maternally-inherited in the F1 father were the same in all cases, so that triploid microsatellite peaks evidencing transmission of both parental homologs could not be found.

Response to sex pheromones

To test whether F1 hybrid males can transmit paternal pheromone preferences to their offspring, we tested and compared response patterns to both C-phe (*P. citri*) and F-phe (*P. ficus*) pheromones between groups of pure males from both species and F2 offspring of CF fathers and *P. citri* mothers. Under complete PGE, CF males should always transmit *P. citri* (i.e. maternal) pheromone preferences to their sons and therefore males from F2 broods should exhibit identical pheromone responses to pure *P. citri* males.

As expected, we found that most pure species males showed a response toward their conspecific pheromone (86.3% of *P. citri* males responded to C-phe and 80.1% of *P. ficus* males responded to F-phe), but we also found strong cross-attraction to the pheromone from the other species (47.1% of *P. citri* males were attracted to F-phe and 53.8% of *P. ficus* males to C-phe). The F2 offspring of CF fathers crossed to *P. citri* mothers showed similar responses to *P. citri* males: 82.7% of them were attracted to C-phe, while 56.5% responded to F-phe. (Fig. 3A). Attraction to both pheromones was shown by 41.2% of *P. citri* males and 53.8% of *P. ficus* males, while 7.8% and 19.2% failed to respond to either pheromone respectively. The frequencies of F2 males that showed response to both pheromones (49.3%) and lack of response to either (10.1%) were similar to *P. citri* males (Fig. 3B).

A series of mixed models were used to test for differences in sex pheromone response patterns across the three different genotypes (Table S3). First, we fitted a binomial mixed model to detect significant differences in proportion of males from each genotype that responded to C-phe and F-phe. We found a significant effect of the interaction between

genotype and pheromone ($LR_{8,6}=20.59$, $p<0.001$). The order in which males were exposed to the pheromones did not have an effect on response ($LR_{8,7}=0$, $p=0.997$). Male identity, fitted as a random effect, explained 18.56% of the variance in response ($\sigma^2_{ID}=0.1856$). *Post hoc* comparisons revealed significant differences in pheromone response between intraspecific males from both species: *P. citri* males showed stronger response to C-phe than *P. ficus* males ($Z=-2.856$, $p = 0.047$) but, conversely, *P. ficus* males were not more strongly attracted to their own pheromone than *P. citri* males ($Z=2.669$, $p=0.079$). Comparisons between how these two genotypes responded to both pheromones revealed a similar pattern: *P. citri* males were more attracted to C-phe than to F-phe ($Z=-3.933$, $p=0.001$), but there was no significant difference in attraction to either pheromone in *P. ficus* males ($Z=2.120$, $p=0.2701$). We found no significant difference in response to either pheromone between *P. citri* males and F2 males (C-phe: $Z=-0.374$, $p=0.9990$; F-phe: $Z=1.269$, $p=0.7961$).

Second, a linear mixed model was fitted to test whether there was any difference across genotypes in intensity of attraction, represented by total time spent by responding males in contact with the sex pheromones (Fig. 3C). Again, we found a significant interaction between genotype and pheromone ($LR_{9,7}=13.443$, $p=0.012$) and no effect of order of exposure ($LR_{9,8}=0.1931$, $p=0.6603$). The proportion of the variance explained by male identity was estimated to be 11% ($\sigma^2_{ID}=0.3996$). *Post hoc* comparisons revealed that both *P. citri* and F2 responsive males spent more time in contact with C-phe than F-phe ($Z=2.120$, $p<0.001$ and $Z=-5.120$, $p<0.001$), but *P. ficus* males did not show a significant difference in contact time with either pheromone ($Z=0.766$, $p=0.972$). No significant differences in contact time with either C-phe nor F-phe were found between *P. citri* and F2 males.

Accepted Article

Finally, a second linear mixed model was used to test for differences in speed of response across genotypes (Fig. 3d). In contrast with previous models, we did not find any significant difference in time to first contact with the pheromones across the three genotypes: there was no significant effect of an interaction between genotype and pheromone ($LR_{9,7} = 3.8853$, $p=0.1433$). Again, order of exposure to pheromones had no significant effect either ($LR_{9,8} = 0.9010$, $p=0.3425$). Male identity explained 19% of the variance ($\Omega^2_{ID}=0.5528$). Together, these models revealed no difference between *P. citri* and F2 males, indicating that CF males were not able to transmit paternal pheromone preferences to their offspring.

Discussion

Paternal genome elimination is a genetic system characterised by whole-genome meiotic drive of maternally-inherited chromosomes in males at the expense of paternally-inherited homologs. Because of this extreme deviation from fair Mendelian inheritance, PGE is expected to generate intragenomic conflict between maternal and paternal haploid genomes within males. The evolutionary success of PGE, which has independently emerged several times in Arthropoda and is estimated to be present in over 10,000 species (Burt & Trivers, 2006; Gardner & Ross, 2014; de la Filia *et al.*, 2015), suggests that this conflict has been irrevocably resolved in favour of maternal genomes. Yet this notion seems difficult to reconcile with the dramatic differences in timing of elimination and degree of expression of paternal chromosomes observed not only across PGE origins, but also between closely related species (Normark, 2003; Ross *et al.*, 2010a). Verbal models have predicted a coevolutionary arms race between parental genomes under PGE, triggered by strong selection on the paternal genome to escape elimination and subsequent maternal counteradaptations (Herrick & Seger, 1999; Burt & Trivers, 2006; Ross *et al.*, 2010a). In this study, we aimed to determine whether there is scope for such an arms race by confronting independently-evolving maternal and paternal genomes within males produced in hybrid and

intraspecific crosses. We tracked the inheritance of both a genotypic (microsatellite markers) and a phenotypic trait (sex pheromone response) to determine if these males exhibited incomplete PGE consistent with a mismatch between parental genomes. The results of these experiments suggest that elimination of paternally-derived chromosomes is not completely effective, implying scope for intragenomic conflict, but do not offer enough evidence to infer the existence of an arms race between parental genomes.

Detectable instances of transmission of paternal chromosomes through males but no evidence of a coevolutionary arms race between parental genomes

F2 genotypes consistent with escapes of paternal alleles could be found in both hybrid and intraspecific males. Although these escapes were relatively few, they are far from negligible considering the limitations of a classical microsatellite approach with a limited number of diagnostic markers. We genotyped up to 12 F2 offspring per cross, less than 5% of the average number of eggs laid by *P. citri* females in experimental conditions (300-500 eggs) (Myers, 1932; Ross *et al.*, 2010b). Also, we could only use three informative markers for intraspecific crosses, which falls short of covering the haploid complement of these species ($n=5$) (Hughes-Schrader, 1948). Even so, we could detect escapes at a frequency of 0.4-2.5%, which is substantial at the population scale. If anything, our study is likely to underestimate escapes due to partial genome coverage and low offspring number that can be feasibly genotyped with such a design. As for the existence of a coevolutionary arms race between parental genomes in mealybugs, these results are inconclusive. We did not find a higher frequency of escapes in hybrids than in intraspecific males, which would be indirect evidence for historical coevolution of paternal and maternal genomes. Also, for such an arms race to occur, the ability of paternal alleles to escape elimination must be heritable. The experimental design does not allow determining whether escapes are accidental or if

there is a heritable component to incomplete PGE, which would require a larger multi-generational crossing design.

The observed leakages of paternal alleles cannot be explained by recombination, since meiosis is achiasmatic in mealybug males (Bongiorni et al. 2004), so it must be attributed to transmission of entire paternal chromosomes. Our results cannot reveal whether escaped paternal chromosomes are transmitted in addition to their maternal homologs or by replacing them, but indicate that leakages do not involve the complete paternally-inherited set: even when half of the males exhibiting incomplete PGE transmitted a paternal allele at more than one locus at once, only maternal copies were transmitted at other informative loci. This indicates that paternal escapes can involve one or more chromosomes at the same time (our genome assemblies are not complete enough to assign markers to chromosomes and linkage relationships between markers are unknown, so loci affected by paternal transmission simultaneously could be situated on the same chromosome), but not all. We did not find a clear pattern across loci suggesting differences in likelihood to escape elimination either: most paternal escapes were found at Pci-7, but our detection power was highest for this locus.

However, due to the low number of F2 individuals found to receive a paternal allele in this study, these escapes must be interpreted with caution. Although the experiments presented in this chapter were carried out in controlled conditions in the laboratory, reducing chances of misassignment of individuals, other factors could account for the presence of seemingly escaped alleles in the offspring. The frequency of F2 genotypes with an escaped allele found in this study is in the order of 10^{-3} , which falls within the range of typical error rates in microsatellite studies (Pompanon *et al.* 2005; Hoffman & Amos 2005; Guichoux *et al.* 2011) and higher frequency SSR mutation rates (Ellegren 2000). Common causes of reproducible error, such as null alleles or allelic dropout (Dakin & Avise 2004), can be confidently excluded, as all escapes resulted in heterozygous genotypes. However, of

particular concern in our methodology could be cross-contamination between samples, since DNA extractions were performed in 96-well plates instead of individual tubes. For hybrid crosses, though, the reappearance of diagnostic *P. ficus* alleles in a single individual cannot be explained by contamination, since all other individuals in the same plate exclusively carried *P. citri* alleles transmitted by their hybrid fathers and their *P. citri* mothers; also, two simultaneous mutations to *P. ficus* alleles affecting the maternal *P. citri* genome in a F1 hybrid would be extremely unlikely. However, independent assessment of paternal escapes through more robust SNP-based parentage methods, yielding a much higher number of traceable markers (Elshire *et al.*, 2011; Kaiser *et al.*, 2017), would offer a superior evaluation of paternal chromosome leakages and provide information on their distribution in the genome, which cannot be inferred with this microsatellite panel. In combination with a deeper pedigree, this approach would facilitate exploring heritability of paternal escapes in mealybugs and increase our power to examine the coevolutionary dynamics between maternally- and paternally-inherited genomes.

A likely cause of transmission of paternal chromosomes: sporadic failure of meiotic parent-of-origin discrimination mechanisms

A complete understanding of PGE at the molecular level is still lacking, although available data provides some clues on how paternal chromosome leakages might occur. Mealybug spermatogenesis has been studied extensively and the sequence of events and timing of paternal genome elimination are well described (Hughes-Schrader, 1948; Bongiorno *et al.*, 2004; 2009). In mealybugs, meiosis follows an inverted sequence (Chandra, 1962; Viera *et al.*, 2008) and segregation of parental homologs is delayed until anaphase II, which involves a monopolar spindle that only interacts with the euchromatic maternal set. Only the spermatids carrying maternal chromosomes progress to complete sperm maturation, while spermatid nuclei containing the paternal set, which lags behind in anaphase II, degenerate (Bongiorno *et al.*, 2004). How can paternal chromosomes escape this fate? Several lines of

This article is protected by copyright. All rights reserved.

evidence suggest that escapees must undergo a reversal of heterochromatinization to allow attachment of the monopolar spindle. In the mealybug *Pseudococcus viburni*, paternally-inherited material that loses its condensed state during meiosis (either supernumerary B chromosomes or irradiation damaged autosomes) segregate into active sperm with the maternal complement (Nur, 1962; Brown & Nur, 1964; Nur, 1970). Moreover, due to the holocentric nature of mealybug chromosomes (i.e. they lack a localised centromere) (Schrader, 1935; Wrensch *et al.*, 1994), partial lack of heterochromatinization can be sufficient for spindle attachment: translocated chromosomes with both euchromatinized maternal and condensed paternal segments have been shown to migrate preferentially with the maternal set (Nur, 1970). If reversal of heterochromatinization is necessary for paternal replacement of maternal chromosomes, either mutations or sporadic failures (or manipulation by the paternal genome) of the epigenetic machinery that codes parent-of-origin chromosome information in mealybugs during spermatogenesis, such as DNA methylation levels (Bongiorni *et al.*, 1999) or histone modifications (Khosla *et al.*, 2006; Prantera & Bongiorni, 2012)—which undergo extensive reorganization during meiosis (Bongiorni *et al.*, 2009)—, could be responsible for paternal leakages.

Transmission of sex pheromone preferences through CF hybrids confirms PGE

We found no evidence of transmission of paternal sex pheromone preferences through males. An important difference between our study and previous work on pheromone response that complicated the predicted outcome of this experiment is cross-attraction to C-phe shown by half of the tested *P. ficus* males, which does not occur in wild populations (Kol-Maimon *et al.*, 2014b) and had only been reported before as a rare event in laboratory conditions (Kol-Maimon *et al.*, 2010). The reasons for this cross-attraction are unclear and cannot be attributed to contamination of *P. ficus* experimental cultures with *P. citri* males, as we routinely genotyped *P. ficus* individuals used in trials with our diagnostic microsatellite panel and, additionally, confirmed the species identify of the PF_1-1 line using common

Accepted Article

barcoding regions (Table S4). Nevertheless, our statistical analysis did not detect differences in different components of pheromone response between male offspring of CF hybrids and the grandmaternal species, *P. citri*. The genetic architecture of sex pheromone response remains unexplored in mealybugs, yet in other insect species such as moths and *Drosophila* the specificity of male pheromone response has been shown to be controlled by single genes or several tightly linked loci (Roelofs *et al.*, 1987; Löfstedt, 1993; Kurtovic *et al.*, 2007; Gould *et al.*, 2010). If this is also the case in mealybugs, leakages of paternal chromosomes could be sufficient for transmission of the genetic toolkit involved in pheromone response to F2 males, but expression of preference would be dependent on overriding silencing of paternal chromosomes.

Patrilineal inheritance of sex pheromone preferences was previously reported by (Kol-Maimon *et al.*, 2014b) in an analogous experimental setup using FC males. We were unable to raise viable FC males and could only test sex pheromone response in F2 broods fathered in the reciprocal cross, and since their study did not explore paternal transmission through CF hybrids, both studies may be complementary and suggest a parental species effect in PGE failure, with *P. citri* alleles being more prone to be expressed in a *P. ficus* maternal background than vice versa. Taken together, these two studies reveal differences in the ability of reciprocal hybrid mealybug males to transmit and express paternal preferences, which most likely depend on asymmetric interactions between the genomes of these species in a hybrid background. This is further supported by the strong differences in mortality of reciprocal hybrid males found in this and, to a lesser magnitude, previous studies (Rotundo & Tremblay, 1982; Tranfaglia & Tremblay, 1982). Early condensation of paternal chromosomes during male development should prevent the expression of paternal alleles, as shown by inheritance studies of phenotypic markers in *P. citri*, which are expressed in males when maternally-inherited only and regardless of dominance (Brown & Nur, 1964; Brown & Wiegmann, 1969). Since maternal genomes are responsible for maintaining paternal chromosomes silencing in mealybugs (Brown & Nur, 1964; Ross *et al.*, 2010a), a

convincing explanation for the reproducible failure of FC matings to produce viable sons would be maternal *P. ficus* backgrounds failing to silence paternal *P. citri* genomes, leading to expression of harmful Dobzhansky-Muller incompatibilities between parental genomes (Orr, 1996; Johnson, 2010). Several experiments can be suggested to test this hypothesis: for instance, comparing patterns of paternal chromosome heterochromatization in reciprocal hybrid males during progressive developmental stages, to determine whether loss of silencing in FC males coincides with timing of mortality, or directly determine degree of paternal chromosome expression in reciprocal hybrids via allele-specific qPCR or RNA-sequencing.

Can paternal genome escapes challenge PGE?

PGE has a long and successful evolutionary history. The broad taxonomic distribution of PGE in arthropods and its presence in very large, species-rich groups—e.g. scale insects (Hemiptera) (Gullan & Cook, 2007), gall midges (Diptera) (Espírito-Santo & Fernandes, 2007), lice (Psocodea) (Li *et al.*, 2015)—suggest a very evolutionary stable mode of reproduction. However, a closer look at its distribution in certain groups such as scale insects—by far the most speciose and diverse group arising from a single PGE origin (Gardner & Ross, 2014)—reveals recurrent transitions between different forms of PGE (early/late elimination of paternal chromosomes, somatic silencing), which might be the outcome of underlying turmoil between paternal and maternal genomes. For example, the evolution of more complex forms of PGE in which some or all paternal chromosomes are eliminated earlier than in the ancestral system present in mealybugs has been interpreted as the outcome of maternal moves to obliterate resistance of paternal alleles during spermatogenesis (Herrick & Seger, 1999). Also, PGE has independently reverted to diploidy at least twice in the family Eriococcidae (Nur, 1980; Normark, 2003; Ross *et al.*, 2010a) These reversions show that paternal responses to PGE can evolve and become

successful, but are these cases exceptional or an extreme manifestation of incomplete maternal control inherent to PGE systems?

Paternal escapes are difficult to detect and study due to their infrequent occurrence and the low sensitivity and high error rates of methodologies used to uncover them. For example, possible events of paternal transmission in a germline PGE species, the coffee borer beetle *Hypothenemus hampei* (Coleoptera: Scolytidae), could either not be distinguished from misclassification of individuals exhibiting genotypes incompatible with PGE or were dismissed (Borsa & Kjellberg, 1996; Borsa & Coustau, 1996). The first clear demonstration of paternal transmission through males was obtained in another germline PGE species, the human louse *Pediculus humanus* (McMeniman & Barker, 2005; de la Filia *et al.*, 2017). *Planococcus* mealybugs (Kol-Maimon *et al.*, 2014b, this study) would be the second confirmed case of patrilineal inheritance, as the results of both these studies suggest. A comparison between these two cases of paternal leakage brings out some interesting considerations. First, the mode of paternal escape appears to be the same, via replacement of maternal homologues in sperm. Second, human louse and mealybugs both have the most basal form of PGE, where paternal chromosomes are not destroyed prior to spermatogenesis and undergo meiosis with their maternal counterparts, unlike in more evolved forms of PGE (Ross *et al.*, 2010a), thus potentially creating more scope for paternal resistance adaptations to evolve. Furthermore, paternal escapes are more frequent in both head and body lice than in mealybugs, which could be related to the apparent lack of paternal chromosome heterochromatinization in *P. humanus* (de la Filia *et al.*, 2017) if the hypothesis of paternal silencing as an evolutionary maternal response to paternal resistance (Herrick & Seger, 1999) is correct.

Accepted Article

However, these observations remain anecdotal until more cases of incomplete PGE are reported and evidence can be drawn from their phylogenetic distribution and comparisons between the different manifestations of this genetic system. Here, we have obtained inheritance patterns that suggest sporadic patrilineal inheritance in mealybugs and a solid ground to fully explore the dynamics of an evolutionary arms race between parental alleles under PGE in future broader studies using *Planococcus* or other mealybug species. Other germline PGE species with or without paternal chromosome silencing that can be easily bred in the laboratory, such as the coffee borer beetle, book lice (Hodson *et al.*, 2017) or sciarid flies, are promising candidates for inheritance studies aimed at determining whether paternal chromosome escapes that can challenge maternal control in basal PGE taxa are the norm rather than the exception.

Supporting Information

Appendix S1. Supplementary tables

Appendix S2. Hybrid F1 males and F2 offspring genotypes

Appendix S3. Transmission ratios for hybrid F1 males

Appendix S4. Intraspecific F1 males and F2 offspring genotypes

Appendix S5. Transmission ratios for intraspecific F1 males

References

- Bachtrog, D., Mank, J.E., Peichel, C.L., Kirkpatrick, M., Otto, S.P., Ashman, T.-L., *et al.* 2014. Sex determination: why so many ways of doing it? *PLoS Biology* **12**: e1001899.
- Bates, D., Mächler, M., Bolker, B. & Walker, S. 2015. Fitting Linear Mixed-Effects Models Using lme4. *Journal of Statistical Software* **67**:1-48
- Bierl-Leonhardt, B.A., Moreno, D.S., Schwarz, M., Fargerlund, J. & Plimmer, J.R. 1981. Isolation, identification and synthesis of the sex pheromone of the citrus mealybug, *Planococcus citri* (Risso). *Tetrahedron Letters* **22**: 389–392.
- Blackmon, H., Hardy, N.B. & Ross, L. 2015. The evolutionary dynamics of haplodiploidy: genome architecture and haploid viability. *Evolution* **69**: 2971–2978.
- Bongiorni, S. & Pranterà, G. 2003. Imprinted facultative heterochromatization in mealybugs. *Genetica* **117**: 271–279.
- Bongiorni, S., Cintio, O. & Pranterà, G. 1999. The relationship between DNA methylation and chromosome imprinting in the coccid *Planococcus citri*. *Genetics* **151**: 1471–1478.
- Bongiorni, S., Fiorenzo, P., Pippoletti, D. & Pranterà, G. 2004. Inverted meiosis and meiotic drive in mealybugs. *Chromosoma* **112**: 331–341.
- Bongiorni, S., Pugnali, M., Volpi, S., Bizzaro, D., Singh, P.B. & Pranterà, G. 2009. Epigenetic marks for chromosome imprinting during spermatogenesis in coccids. *Chromosoma* **118**: 501–512.
- Borsa, P. & Coustau, C. 1996. Single-stranded DNA conformation polymorphism at the Rdl locus in *Hypothenemus hampei* (Coleoptera: Scolytidae). *Heredity* **76**: 124-119.
- Borsa, P. & Kjellberg, F. 1996. Experimental evidence for pseudo-arrhenotoky in *Hypothenemus hampei* (Coleoptera: Scolytidae). *Heredity* **76**: 130–135.
- Brown, S.W. & Nur, U. 1964. Heterochromatic chromosomes in the coccids. *Science* **145**: 130–136.
- Brown, S.W. & Wiegmann, L.I. 1969. Cytogenetics of the mealybug *Planococcus citri* (Risso)(Homoptera: Coccoidea): genetic markers, lethals, and chromosome rearrangements. *Chromosoma* **28**: 255–279.
- Bull, J.J. 1979. An advantage for the evolution of male haploidy and systems with similar genetic transmission. *Heredity* **43**: 361–381.
- Burt, A. & Trivers, R. 2006. Genes in conflict: the biology of selfish genetic elements. Harvard University Press, Cambridge, MA.
- Camacho, J.P.M., Sharbel, T.F. & Beukeboom, L.W. 2000. B-chromosome evolution. *Philosophical Transactions of the Royal Society B: Biological Sciences* **355**: 163–178.

- Chandra, H.S. 1962. Inverse meiosis in triploid females of the mealy bug, *Planococcus citri*. *Genetics* **47**: 1441–1454.
- Chmátal, L., Gabriel, S.I., Mitsainas, G.P., Martínez-Vargas, J., Ventura, J., Searle, J.B., *et al.* 2014. Centromere strength provides the cell biological basis for meiotic drive and karyotype evolution in mice. *Current Biology* **24**: 2295–2300.
- De la Folia, de, A.G., Bain, S.A. & Ross, L. 2015. Haplodiploidy and the reproductive ecology of Arthropods. *Current Opinions in Insect Science* **9**: 36–43.
- De la Folia, A.G., Andrewes, S., Clark, J.M. & Ross, L. 2017. The unusual reproductive system of head and body lice (*Pediculus humanus*). *Medical and Veterinary Entomology* **32**: 226-234.
- Elshire, R.J., Glaubitz, J.C., Sun, Q., Poland, J.A., Kawamoto, K., Buckler, E.S., *et al.* 2011. A robust, simple genotyping-by-sequencing (GBS) approach for high diversity species. *PLoS ONE* **6**: e19379.
- Espírito-Santo, M.M. & Fernandes, G.W. 2007. How many species of gall-inducing insects are there on earth, and where are they? *Annals of the Entomological Society of America* **100**: 95–99.
- Fishman, L. & Willis, J.H. 2005. A novel meiotic drive locus almost completely distorts segregation in *Mimulus* (monkeyflower) hybrids. *Genetics* **169**: 347–353.
- Frank, S.A. 1991. Divergence of meiotic drive-suppression systems as an explanation for sex-biased hybrid sterility and inviability. *Evolution* **262–267**.
- Gardner, A. & Ross, L. 2014. Mating ecology explains patterns of genome elimination. *Ecology Letters* **17**: 1602–1612.
- Gardner, A. & Úbeda, F. 2017. The meaning of intragenomic conflict. *Nature Ecology & Evolution* **1**: 1807.
- Gould, F., Estock, M., Hillier, N.K., Powell, B., Groot, A.T., Ward, C.M., *et al.* 2010. Sexual isolation of male moths explained by a single pheromone response QTL containing four receptor genes. *Proceedings of the National Academy of Sciences* **107**: 8660–8665.
- Gullan, P.J. & Cook, L.G. 2007. Phylogeny and higher classification of the scale insects (Hemiptera: Sternorrhyncha: Coccoidea). *Zootaxa* **1668**: 413–425.
- Herrick, G. & Seger, J. 1999. Imprinting and paternal genome elimination in insects. In *Genomic Imprinting: An Interdisciplinary Approach* (ed. R. Ohlsson), pp. 41–71. Springer-Verlag, New York.
- Hinkens, D.M., McElfresh, J.S. & Millar, J.G. 2001. Identification and synthesis of the sex pheromone of the vine mealybug, *Planococcus ficus*. *Tetrahedron Letters* **42**: 1619–1621. Elsevier.
- Hodson, C.N., Hamilton, P.T., Dilworth, D., Nelson, C.J., Curtis, C.I. & Perlman, S.J. 2017.

Paternal Genome Elimination in *Liposcelis* Booklice (Insecta: Psocodea). *Genetics* **206**: 1091-1100.

Hothorn, T., Bretz, F. & Westfall, P. 2008. Simultaneous inference in general parametric models. *Biometrical Journal* **50**: 346–363.

Hughes-Schrader, S. 1948. Cytology of coccids (Coccoidea-Homoptera). *Advances in Genetics* **2**: 127–203.

Hurst, G.D. & Werren, J.H. 2001. The role of selfish genetic elements in eukaryotic evolution. *Nature Reviews Genetics* **2**: 597.

Hurst, L.D. & Pomiankowski, A. 1991. Causes of sex ratio bias may account for unisexual sterility in hybrids: a new explanation of Haldane's rule and related phenomena. *Genetics* **128**: 841–858.

Johnson, N.A. 2010. Hybrid incompatibility genes: remnants of a genomic battlefield? *Trends in Genetics*. **26**: 317–325.

Kaiser, S.A., Taylor, S.A., Chen, N., Sillett, T.S., Bondra, E.R. & Webster, M.S. 2017. A comparative assessment of SNP and microsatellite markers for assigning parentage in a socially monogamous bird. *Molecular Ecology Resources* **17**: 183–193.

Khosla, S., Mendiratta, G. & Brahmachari, V. 2006. Genomic imprinting in the mealybugs. *Cytogenetic and genome research* **113**: 41–52.

Kol-Maimon, H., Ghanim, M., Franco, J.C. & Mendel, Z. 2014a. Evidence for gene flow between two sympatric mealybug species (Insecta; Coccoidea; Pseudococcidae). *PLoS ONE* **9**: e88433.

Kol-Maimon, H., Levi-Zada, A., Franco, J.C., Dunkelblum, E., Protasov, A., Eliyaho, M., *et al.* 2010. Male behaviors reveal multiple phenotypes within vine mealybug *Planococcus ficus* (Signoret) (Hemiptera; Pseudococcidae) populations. *Naturwissenschaften* **97**: 1047–1057.

Kol-Maimon, H., Mendel, Z., Franco, J.C. & Ghanim, M. 2014b. Paternal inheritance in mealybugs (Hemiptera: Coccoidea: Pseudococcidae). *Naturwissenschaften* **101**: 791–802.

Kurtovic, A., Widmer, A. & Dickson, B.J. 2007. A single class of olfactory neurons mediates behavioural responses to a *Drosophila* sex pheromone. *Nature* **446**: 542.

Larracuente, A.M. & Presgraves, D.C. 2012. The selfish Segregation Distorter gene complex of *Drosophila melanogaster*. *Genetics* **192**: 33–53.

Lenormand, T., Engelstädter, J., Johnston, S.E., Wijnker, E. & Haag, C.R. 2016. Evolutionary mysteries in meiosis. *Philosophical Transactions of the Royal Society B: Biological Sciences* **371**: 20160001.

- Li, H., Shao, R., Song, N., Song, F., Jiang, P., Li, Z., *et al.* 2015. Higher-level phylogeny of paraneopteran insects inferred from mitochondrial genome sequences. *Scientific Reports* **5**: 8527.
- Lindholm, A.K., Dyer, K.A., Firman, R.C., Fishman, L., Forstmeier, W., Holman, L., *et al.* 2016. The ecology and evolutionary dynamics of meiotic drive. *Trends in Ecology & Evolution* **31**: 315–326.
- Löfstedt, C. 1993. Moth pheromone genetics and evolution. *Philosophical Transactions of the Royal Society B: Biological Sciences* **340**: 167–177.
- Malausa, T., Fenis, A., Warot, S., Germain, J.F., Ris, N., Prado, E., *et al.* 2011. DNA markers to disentangle complexes of cryptic taxa in mealybugs (Hemiptera: Pseudococcidae). *Journal of Applied Entomology* **135**: 142–155.
- Martins, R.F., Zina, V., Da Silva, E.B., Rebelo, M.T., Figueredo, E., Mendel, Z., *et al.* 2012. Isolation and characterization of fifteen polymorphic microsatellite loci for the citrus mealybug, *Planococcus citri* (Hemiptera: Pseudococcidae), and cross-amplification in two other mealybug species. *Journal of Genetics* **93**: 75-78.
- McMeniman, C.J. & Barker, S.C. 2005. Transmission ratio distortion in the human body louse, *Pediculus humanus* (Insecta: Phthiraptera). *Heredity* **96**: 63.
- Myers, E.L. 1932. Two economic greenhouse mealybugs of Mississippi. *Journal of Economic Entomology* **25**: 891–896.
- Normark, B.B. 2006. Perspective: maternal kin groups and the origins of asymmetric genetic systems—genomic imprinting, haplodiploidy, and parthenogenesis. *Evolution* **60**: 631–642. BioOne.
- Normark, B.B. 2003. The evolution of alternative genetic systems in insects. *Annual Review of Entomology* **48**: 397–423.
- Normark, B.B. & Ross, L. 2014. Genetic conflict, kin and the origins of novel genetic systems. *Philosophical Transactions of the Royal Society B: Biological Sciences* **369**: 20130364.
- Nur, U. 1962. A supernumerary chromosome with an accumulation mechanism in the lecanoid genetic system. *Chromosoma* **13**: 249–271.
- Nur, U. 1980. Evolution of unusual chromosome systems in scale insects (Coccoidea: Homoptera). *Insect Cytogenetics* 97–117.
- Nur, U. 1970. Translocations between eu- and heterochromatic chromosomes, and spermatocytes lacking a heterochromatic set in male mealy bugs. *Chromosoma* **29**: 42–61.
- Orr, H.A. 1996. Dobzhansky, Bateson, and the genetics of speciation. *Genetics* **144**: 1331–1335.

- Phadnis, N. & Orr, H.A. 2009. A single gene causes both male sterility and segregation distortion in *Drosophila* hybrids. *Science* **323**: 376–379.
- Prantera, G. & Bongiorno, S. 2012. Mealybug chromosome cycle as a paradigm of epigenetics. *Genetics Research International*: 867390.
- Roelofs, W., Glover, T., Tang, X.-H., Sreng, I., Robbins, P., Eckenrode, C., *et al.* 1987. Sex pheromone production and perception in European corn borer moths is determined by both autosomal and sex-linked genes. *Proceedings of the National Academy of Sciences* **84**: 7585–7589.
- Ross, L., Pen, I. & Shuker, D.M. 2010a. Genomic conflict in scale insects: the causes and consequences of bizarre genetic systems. *Biological Reviews* **85**: 807-828.
- Ross, L., Langenhof, M.B., Pen, I., Beukeboom, L.W., West, S.A. & Shuker, D.M. 2010b. Sex allocation in a species with paternal genome elimination: the roles of crowding and female age in the mealybug *Planococcus citri*. *Evolutionary Ecology Research* **12**: 89–104.
- Rotundo, G. & Tremblay, E. 1982. Hybridization and sex pheromone responses in two closely related mealybug species (Homoptera: Pseudococcidae). *Systematic Entomology* **7**: 475–478.
- Schimenti, J. 2000. Segregation distortion of mouse t haplotypes: the molecular basis emerges. *Trends in Genetics*. **16**: 240–243.
- Schrader, F. 1935. Notes and the mitotic behavior of long chromosomes. *Cytologia* **6**: 422–430.
- Schwander, T. & Oldroyd, B.P. 2016. Androgenesis: where males hijack eggs to clone themselves. *Philosophical Transactions of the Royal Society B: Biological Sciences* **371**: 20150534.
- Tao, Y., Masly, J.P., Araripe, L., Ke, Y. & Hartl, D.L. 2007a. A sex-ratio meiotic drive system in *Drosophila simulans*. I: an autosomal suppressor. *PLoS Biology* **5**: e292.
- Tao, Y., Araripe, L., Kingan, S.B., Ke, Y., Xiao, H. & Hartl, D.L. 2007b. A sex-ratio meiotic drive system in *Drosophila simulans*. II: an X-linked distorter. *PLoS Biology* **5**: e293.
- Tranfaglia, A. & Tremblay, E. 1982. A morphological comparison between *Planococcus citri* (Ris.), *Planococcus ficus* (Sign.) and their F1 hybrids (Homoptera: Coccoidea: Pseudococcidae). *Entomotaxonomia* **4**: 1–5.
- Úbeda, F., Patten, M.M. & Wild, G. 2015. On the origin of sex chromosomes from meiotic drive. *Proceedings of the Royal Society B: Biological Sciences* **282**: 20141932.
- Viera, A., Page, J. & Rufas, J. 2008. Inverted meiosis: the true bugs as a model to study. *Meiosis* **5**: 137–156.

Werren, J.H. 2011. Selfish genetic elements, genetic conflict, and evolutionary innovation.
Proceedings of the National Academy of Sciences **108**: 10863–10870.

Wrench, D.L., Kethley, J.B. & Norton, R.A. 1994. Cytogenetics of holokinetic chromosomes and inverted meiosis: keys to the evolutionary success of mites, with generalizations on eukaryotes. 282–343. In *Mites* (pp. 282-343). Springer, Boston, MA.

Figure 1.

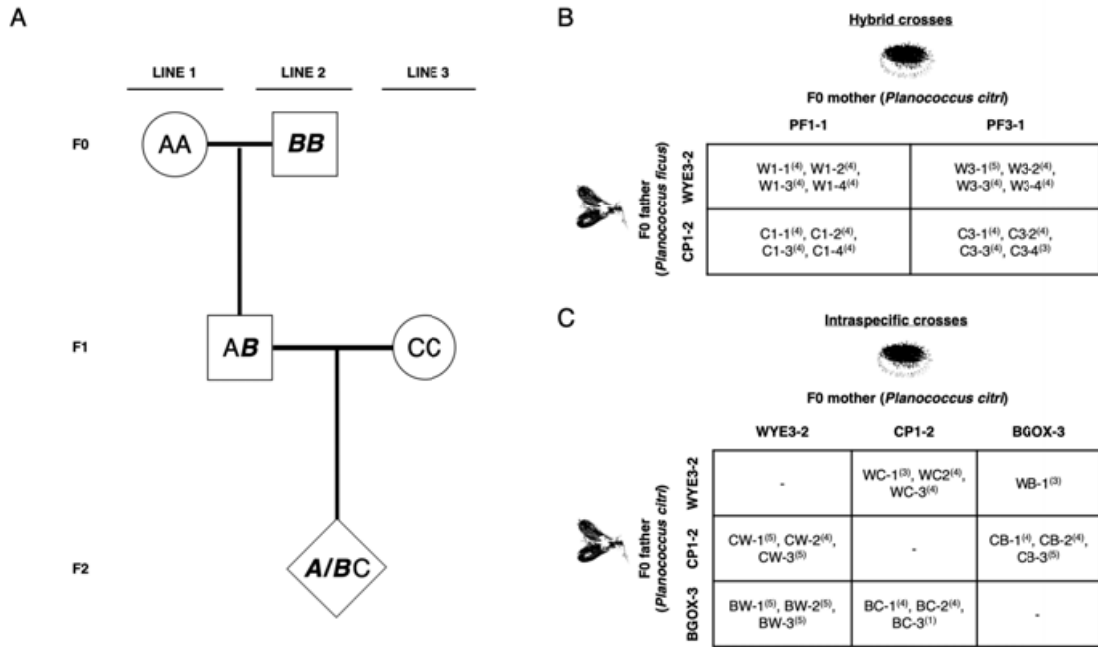

Figure 2.

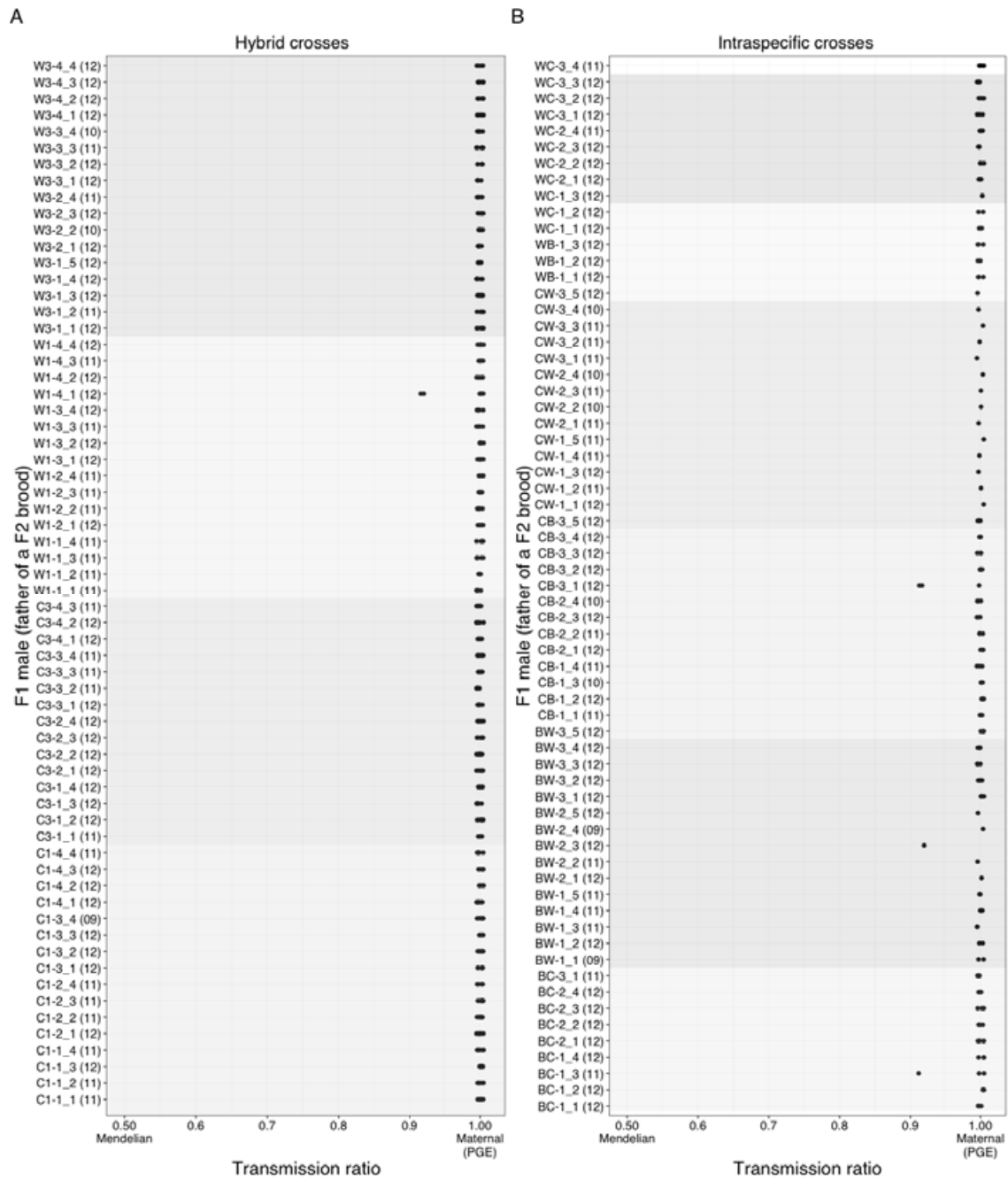

Figure 3.

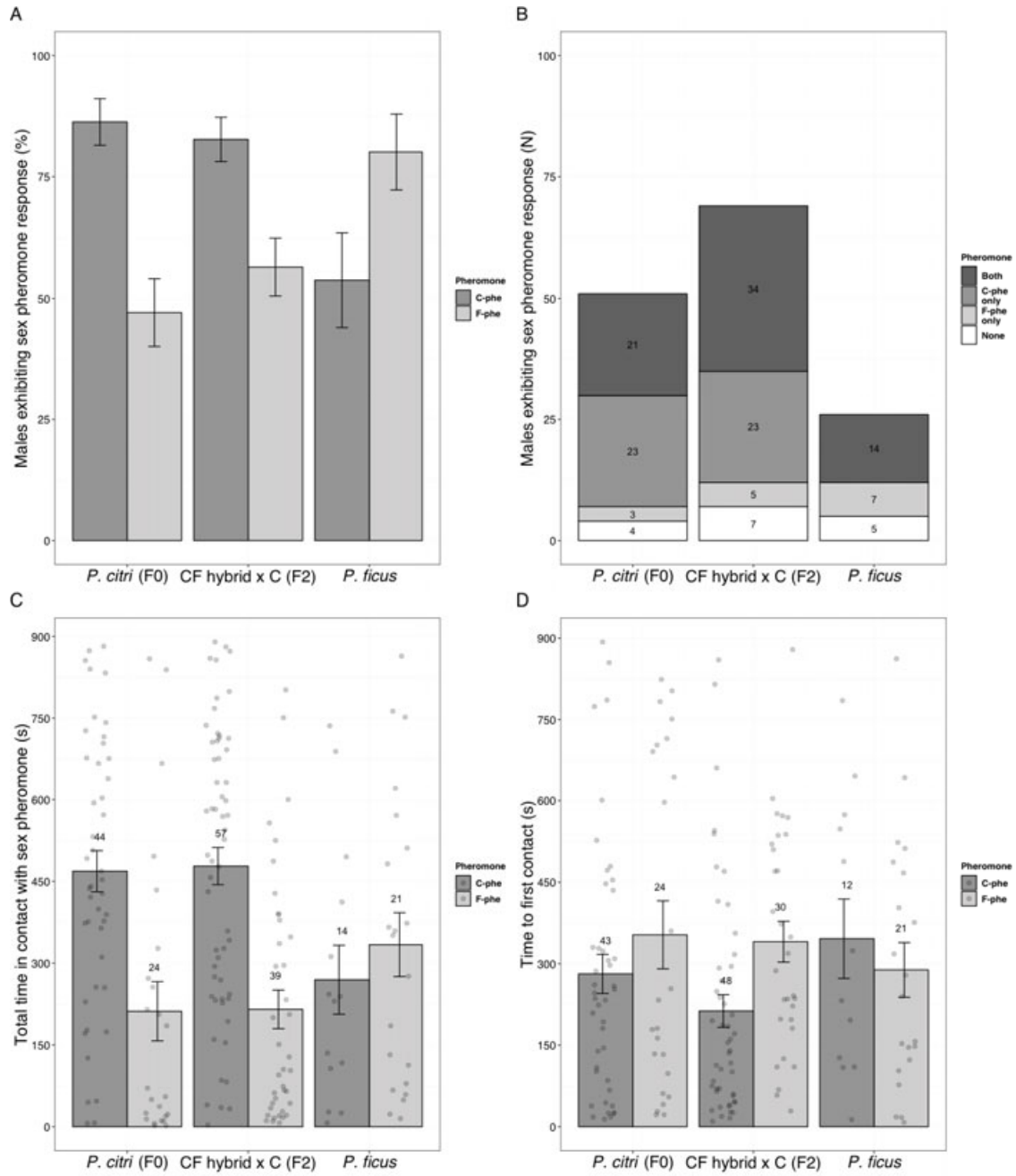

Figure legends

Figure 1. Schematic diagram of crossing design. For both hybrid and intraspecific crosses, a female (circle) from an isofemale line with AA genotype at a given locus was mated to a male (square) from a different line (BB) to produce an F1 brood with AB genotype. F1 males from these broods were mated to a female (CC) to produce F2 broods. F1 male transmission ratios were calculated as frequency of maternal allele A in the F2 offspring. Under complete PGE, only AC genotypes are expected in the F2 offspring, so the presence of BC individuals reveals escapes of paternal alleles through F1 males. (B) Hybrid crosses and genotypes of F1 broods. 4 biological replicates were produced for each F0 cross. The number of hybrid males from each F1 brood mated to produce F2 families is indicated in brackets. (C) Intraspecific *P. citri* crosses and genotypes of F1 broods. 3 biological replicates were produced for each F0 cross, except for WB crosses. The number of hybrid males from each F1 brood mated to produce F2s is indicated in brackets.

Figure 2. Paternal allele transmission ratios for F1 males in hybrid (A) and intraspecific *P. citri* crosses (B). F1 males are labelled as follows: the first two characters denote F0 maternal and paternal genotypes, followed by a number corresponding to the F0 cross and a second number indicating the identity of the male: e.g. C1-1_1 refers to the first F1 male deriving from the first PC_CP1-2 x PF_1-1 F0 cross. Each data point represents a F1 male allele transmission ratio for a single informative marker. The number of successfully genotyped individuals for each F2 family originated by the F1 male is indicated in brackets.

Figure 3. Male response to sex pheromones. 3A, percentage of males from each genotype exhibiting responses to both C-phe and F-phe. 3B, number of males exhibiting attraction to both pheromones, either or none. 3C, number of seconds spent by responding males in contact to both pheromones. 3D, time to first contact of responding males. Error bars represent standard errors (binomial standard error in panel 3A). Number of males exhibiting pheromone response from each genotype is shown above error bars in 3C and 3D.

References

- Bachtrog, D., Mank, J.E., Peichel, C.L., Kirkpatrick, M., Otto, S.P., Ashman, T.-L., *et al.* 2014. Sex determination: why so many ways of doing it? *PLoS Biology* **12**: e1001899.
- Bates, D., Mächler, M., Bolker, B. & Walker, S. 2015. Fitting Linear Mixed-Effects Models Using lme4. *Journal of Statistical Software* **67**:1-48
- Bierl-Leonhardt, B.A., Moreno, D.S., Schwarz, M., Fargerlund, J. & Plimmer, J.R. 1981. Isolation, identification and synthesis of the sex pheromone of the citrus mealybug, *Planococcus citri* (Risso). *Tetrahedron Letters* **22**: 389–392.
- Blackmon, H., Hardy, N.B. & Ross, L. 2015. The evolutionary dynamics of haplodiploidy: genome architecture and haploid viability. *Evolution* **69**: 2971–2978.
- Bongiorni, S. & Pranterà, G. 2003. Imprinted facultative heterochromatization in mealybugs. *Genetica* **117**: 271–279.
- Bongiorni, S., Cintio, O. & Pranterà, G. 1999. The relationship between DNA methylation and chromosome imprinting in the coccid *Planococcus citri*. *Genetics* **151**: 1471–1478.
- Bongiorni, S., Mazzuoli, M., Masci, S. and Pranterà, G., 2001. Facultative heterochromatization in parahaploid male mealybugs: involvement of a heterochromatin-associated protein. *Development*, **128**(19), pp.3809-3817.
- Bongiorni, S., Fiorenzo, P., Pippoletti, D. & Pranterà, G. 2004. Inverted meiosis and meiotic drive in mealybugs. *Chromosoma* **112**: 331–341.
- Bongiorni, S., Pugnali, M., Volpi, S., Bizzaro, D., Singh, P.B. & Pranterà, G. 2009. Epigenetic marks for chromosome imprinting during spermatogenesis in coccids. *Chromosoma* **118**: 501–512.
- Borsa, P. & Coustau, C. 1996. Single-stranded DNA conformation polymorphism at the Rdl locus in *Hypothenemus hampei* (Coleoptera: Scolytidae). *Heredity* **76**: 124-119.
- Borsa, P. & Kjellberg, F. 1996. Experimental evidence for pseudo-arrhenotoky in *Hypothenemus hampei* (Coleoptera: Scolytidae). *Heredity* **76**: 130–135.
- Brown, S.W. & Nur, U. 1964. Heterochromatic chromosomes in the coccids. *Science* **145**: 130–136.
- Brown, S.W. & Wiegmann, L.I. 1969. Cytogenetics of the mealybug *Planococcus citri* (Risso)(Homoptera: Coccoidea): genetic markers, lethals, and chromosome rearrangements. *Chromosoma* **28**: 255–279.
- Bull, J.J. 1979. An advantage for the evolution of male haploidy and systems with similar genetic transmission. *Heredity* **43**: 361–381.
- Burt, A. & Trivers, R. 2006. Genes in conflict: the biology of selfish genetic elements.

Harvard University Press, Cambridge, MA.

- Camacho, J.P.M., Sharbel, T.F. & Beukeboom, L.W. 2000. B-chromosome evolution. *Philosophical Transactions of the Royal Society B: Biological Sciences* **355**: 163–178.
- Chandra, H.S. 1962. Inverse meiosis in triploid females of the mealy bug, *Planococcus citri*. *Genetics* **47**: 1441–1454.
- Chmátal, L., Gabriel, S.I., Mitsainas, G.P., Martínez-Vargas, J., Ventura, J., Searle, J.B., *et al.* 2014. Centromere strength provides the cell biological basis for meiotic drive and karyotype evolution in mice. *Current Biology* **24**: 2295–2300.
- De la Filia, de, A.G., Bain, S.A. & Ross, L. 2015. Haplodiploidy and the reproductive ecology of Arthropods. *Current Opinions in Insect Science* **9**: 36–43.
- De la Filia, A.G., Andrewes, S., Clark, J.M. & Ross, L. 2017. The unusual reproductive system of head and body lice (*Pediculus humanus*). *Medical and Veterinary Entomology* **32**: 226-234.
- Ellegren, H., 2000. Microsatellite mutations in the germline: implications for evolutionary inference. *Trends in genetics*, **16**: 551-558.
- Elshire, R.J., Glaubitz, J.C., Sun, Q., Poland, J.A., Kawamoto, K., Buckler, E.S., *et al.* 2011. A robust, simple genotyping-by-sequencing (GBS) approach for high diversity species. *PLoS ONE* **6**: e19379.
- Espírito-Santo, M.M. & Fernandes, G.W. 2007. How many species of gall-inducing insects are there on earth, and where are they? *Annals of the Entomological Society of America* **100**: 95–99.
- Fishman, L. & Willis, J.H. 2005. A novel meiotic drive locus almost completely distorts segregation in *Mimulus* (monkeyflower) hybrids. *Genetics* **169**: 347–353.
- Frank, S.A. 1991. Divergence of meiotic drive-suppression systems as an explanation for sex-biased hybrid sterility and inviability. *Evolution* **45**: 262–267.
- Gardner, A. & Ross, L. 2014. Mating ecology explains patterns of genome elimination. *Ecology Letters* **17**: 1602–1612.
- Gardner, A. & Úbeda, F. 2017. The meaning of intragenomic conflict. *Nature Ecology & Evolution* **1**: 1807.
- Gould, F., Estock, M., Hillier, N.K., Powell, B., Groot, A.T., Ward, C.M., *et al.* 2010. Sexual isolation of male moths explained by a single pheromone response QTL containing four receptor genes. *Proceedings of the National Academy of Sciences* **107**: 8660–8665.
- Gullan, P.J. & Cook, L.G. 2007. Phylogeny and higher classification of the scale insects (Hemiptera: Sternorrhyncha: Coccoidea). *Zootaxa* **1668**: 413–425.
- Herrick, G. & Seger, J. 1999. Imprinting and paternal genome elimination in insects. In

Genomic Imprinting: An Interdisciplinary Approach (ed. R. Ohlsson), pp. 41–71. Springer-Verlag, New York.

Hinkens, D.M., McElfresh, J.S. & Millar, J.G. 2001. Identification and synthesis of the sex pheromone of the vine mealybug, *Planococcus ficus*. *Tetrahedron Letters* **42**: 1619–1621. Elsevier.

Hodson, C.N., Hamilton, P.T., Dilworth, D., Nelson, C.J., Curtis, C.I. & Perlman, S.J. 2017. Paternal Genome Elimination in *Liposcelis* Booklice (Insecta: Psocodea). *Genetics* **206**: 1091-1100.

Hothorn, T., Bretz, F. & Westfall, P. 2008. Simultaneous inference in general parametric models. *Biometrical Journal* **50**: 346–363.

Hughes-Schrader, S. 1948. Cytology of coccids (Coccoidea-Homoptera). *Advances in Genetics* **2**: 127–203.

Hurst, G.D. & Werren, J.H. 2001. The role of selfish genetic elements in eukaryotic evolution. *Nature Reviews Genetics* **2**: 597.

Hurst, L.D. & Pomiankowski, A. 1991. Causes of sex ratio bias may account for unisexual sterility in hybrids: a new explanation of Haldane's rule and related phenomena. *Genetics* **128**: 841–858.

Johnson, N.A. 2010. Hybrid incompatibility genes: remnants of a genomic battlefield? *Trends in Genetics*. **26**: 317–325.

Kaiser, S.A., Taylor, S.A., Chen, N., Sillett, T.S., Bondra, E.R. & Webster, M.S. 2017. A comparative assessment of SNP and microsatellite markers for assigning parentage in a socially monogamous bird. *Molecular Ecology Resources* **17**: 183–193.

Khosla, S., Mendiratta, G. & Brahmachari, V. 2006. Genomic imprinting in the mealybugs. *Cytogenetic and genome research* **113**: 41–52.

Kol-Maimon, H., Ghanim, M., Franco, J.C. & Mendel, Z. 2014a. Evidence for Gene Flow between Two Sympatric Mealybug Species (Insecta; Coccoidea; Pseudococcidae). *PLoS ONE* **9**: e88433.

Kol-Maimon, H., Levi-Zada, A., Franco, J.C., Dunkelblum, E., Protasov, A., Eliyaho, M., *et al.* 2010. Male behaviors reveal multiple phenotypes within vine mealybug *Planococcus ficus* (Signoret) (Hemiptera; Pseudococcidae) populations. *Naturwissenschaften* **97**: 1047–1057.

Kol-Maimon, H., Mendel, Z., Franco, J.C. & Ghanim, M. 2014b. Paternal inheritance in mealybugs (Hemiptera: Coccoidea: Pseudococcidae). *Naturwissenschaften* **101**: 791–802.

Kurtovic, A., Widmer, A. & Dickson, B.J. 2007. A single class of olfactory neurons mediates behavioural responses to a *Drosophila* sex pheromone. *Nature* **446**: 542.

This article is protected by copyright. All rights reserved.

- Larracuente, A.M. & Presgraves, D.C. 2012. The selfish Segregation Distorter gene complex of *Drosophila melanogaster*. *Genetics* **192**: 33–53.
- Lenormand, T., Engelstädter, J., Johnston, S.E., Wijnker, E. & Haag, C.R. 2016. Evolutionary mysteries in meiosis. *Philosophical Transactions of the Royal Society B: Biological Sciences* **371**: 20160001.
- Li, H., Shao, R., Song, N., Song, F., Jiang, P., Li, Z., *et al.* 2015. Higher-level phylogeny of paraneopteran insects inferred from mitochondrial genome sequences. *Scientific Reports* **5**: 8527.
- Lindholm, A.K., Dyer, K.A., Firman, R.C., Fishman, L., Forstmeier, W., Holman, L., *et al.* 2016. The ecology and evolutionary dynamics of meiotic drive. *Trends in Ecology & Evolution* **31**: 315–326.
- Löfstedt, C. 1993. Moth pheromone genetics and evolution. *Philosophical Transactions of the Royal Society B: Biological Sciences* **340**: 167–177.
- Malausa, T., Fenis, A., Warot, S., Germain, J.F., Ris, N., Prado, E., *et al.* 2011. DNA markers to disentangle complexes of cryptic taxa in mealybugs (Hemiptera: Pseudococcidae). *Journal of Applied Entomology* **135**: 142–155.
- Martins, R.F., Zina, V., Da Silva, E.B., Rebelo, M.T., Figueiredo, E., Mendel, Z., *et al.* 2012. Isolation and characterization of fifteen polymorphic microsatellite loci for the citrus mealybug, *Planococcus citri* (Hemiptera: Pseudococcidae), and cross-amplification in two other mealybug species. *Journal of Genetics* **93**: 75–78.
- McMeniman, C.J. & Barker, S.C. 2005. Transmission ratio distortion in the human body louse, *Pediculus humanus* (Insecta: Phthiraptera). *Heredity* **96**: 63.
- Myers, E.L. 1932. Two economic greenhouse mealybugs of Mississippi. *Journal of Economic Entomology* **25**: 891–896.
- Normark, B.B. 2006. Perspective: maternal kin groups and the origins of asymmetric genetic systems—genomic imprinting, haplodiploidy, and parthenogenesis. *Evolution* **60**: 631–642. BioOne.
- Normark, B.B. 2003. The evolution of alternative genetic systems in insects. *Annual Review of Entomology* **48**: 397–423.
- Normark, B.B. & Ross, L. 2014. Genetic conflict, kin and the origins of novel genetic systems. *Philosophical Transactions of the Royal Society B: Biological Sciences* **369**: 20130364.
- Nur, U. 1962. A supernumerary chromosome with an accumulation mechanism in the lecanoid genetic system. *Chromosoma* **13**: 249–271.
- Nur, U. 1980. Evolution of unusual chromosome systems in scale insects (Coccoidea: Homoptera). *Insect cytogenetics* 97–117.

- Nur, U. 1970. Translocations between eu-and heterochromatic chromosomes, and spermatocytes lacking a heterochromatic set in male mealy bugs. *Chromosoma* **29**: 42–61.
- Orr, H.A. 1996. Dobzhansky, Bateson, and the genetics of speciation. *Genetics* **144**: 1331–1335.
- Phadnis, N. & Orr, H.A. 2009. A single gene causes both male sterility and segregation distortion in *Drosophila* hybrids. *Science* **323**: 376–379.
- Prantera, G. & Bongiorno, S. 2012. Mealybug chromosome cycle as a paradigm of epigenetics. *Genetics Research International*: 867390.
- Roelofs, W., Glover, T., Tang, X.-H., Sreng, I., Robbins, P., Eckenrode, C., *et al.* 1987. Sex pheromone production and perception in European corn borer moths is determined by both autosomal and sex-linked genes. *Proceedings of the National Academy of Sciences* **84**: 7585–7589.
- Ross, L., Pen, I. & Shuker, D.M. 2010a. Genomic conflict in scale insects: the causes and consequences of bizarre genetic systems. *Biological Reviews* **85**: 807-828.
- Ross, L., Langenhof, M.B., Pen, I., Beukeboom, L.W., West, S.A. & Shuker, D.M. 2010b. Sex allocation in a species with paternal genome elimination: the roles of crowding and female age in the mealybug *Planococcus citri*. *Evolutionary Ecology Research* **12**: 89–104.
- Rotundo, G. & Tremblay, E. 1982. Hybridization and sex pheromone responses in two closely related mealybug species (Homoptera: Pseudococcidae). *Systematic Entomology* **7**: 475–478.
- Schimenti, J. 2000. Segregation distortion of mouse t haplotypes: the molecular basis emerges. *Trends in Genetics*. **16**: 240–243.
- Schrader, F. 1935. Notes and the mitotic behavior of long chromosomes. *Cytologia* **6**: 422–430.
- Schwander, T. & Oldroyd, B.P. 2016. Androgenesis: where males hijack eggs to clone themselves. *Philosophical Transactions of the Royal Society B: Biological Sciences* **371**: 20150534.
- Tao, Y., Masly, J.P., Araripe, L., Ke, Y. & Hartl, D.L. 2007a. A sex-ratio meiotic drive system in *Drosophila simulans*. I: an autosomal suppressor. *PLoS Biology* **5**: e292.
- Tao, Y., Araripe, L., Kingan, S.B., Ke, Y., Xiao, H. & Hartl, D.L. 2007b. A sex-ratio meiotic drive system in *Drosophila simulans*. II: an X-linked distorter. *PLoS Biology* **5**: e293.
- Tranfaglia, A. & Tremblay, E. 1982. A morphological comparison between *Planococcus citri* (Ris.), *Planococcus ficus* (Sign.) and their F1 hybrids (Homoptera: Coccoidea: Pseudococcidae). *Entomotaxonomia* **4**: 1–5.

Accepted Article

Úbeda, F., Patten, M.M. & Wild, G. 2015. On the origin of sex chromosomes from meiotic drive. *Proceedings of the Royal Society B: Biological Sciences* **282**: 20141932.

Viera, A., Page, J. & Rufas, J. 2008. Inverted meiosis: the true bugs as a model to study. *Meiosis* **5**: 137–156.

Werren, J.H. 2011. Selfish genetic elements, genetic conflict, and evolutionary innovation. *Proceedings of the National Academy of Sciences* **108**: 10863–10870.

Wrench, D.L., Kethley, J.B. & Norton, R.A. 1994. Cytogenetics of holokinetic chromosomes and inverted meiosis: keys to the evolutionary success of mites, with generalizations on eukaryotes. 282–343. In *Mites* (pp. 282-343). Springer, Boston, MA.