



THE UNIVERSITY *of* EDINBURGH

Edinburgh Research Explorer

Metal-polymer composite sensors for volatile organic compounds: Part 1. Flow-through chemi-resistors

Citation for published version:

Hands, PJW, Laughlin, PJ & Bloor, D 2012, 'Metal-polymer composite sensors for volatile organic compounds: Part 1. Flow-through chemi-resistors', *Sensors and Actuators B: Chemical*, vol. 162, no. 1, pp. 400-408. <https://doi.org/10.1016/j.snb.2011.12.016>

Digital Object Identifier (DOI):

[10.1016/j.snb.2011.12.016](https://doi.org/10.1016/j.snb.2011.12.016)

Link:

[Link to publication record in Edinburgh Research Explorer](#)

Document Version:

Peer reviewed version

Published In:

Sensors and Actuators B: Chemical

General rights

Copyright for the publications made accessible via the Edinburgh Research Explorer is retained by the author(s) and / or other copyright owners and it is a condition of accessing these publications that users recognise and abide by the legal requirements associated with these rights.

Take down policy

The University of Edinburgh has made every reasonable effort to ensure that Edinburgh Research Explorer content complies with UK legislation. If you believe that the public display of this file breaches copyright please contact openaccess@ed.ac.uk providing details, and we will remove access to the work immediately and investigate your claim.



Metal-polymer composite sensors for volatile organic compounds:

Part 1. Flow-through chemi-resistors.

P. J. W. Hands ^{a, 1}, P. J. Laughlin ^b, and D. Bloor ^{a, b, *}

^a Department of Physics, Durham University, South Road, Durham, DH1 3LE, UK

^b Peratech Ltd., Old Repeater Station, Brompton on Swale, North Yorkshire, DL10 7JH, UK.

Abstract.

A new type of chemi-resistor based on a novel metal-polymer composite is described. The composite contains nickel particles with sharp nano-scale surface features, which are intimately coated by the polymer matrix so that they do not come into direct physical contact. No conductive chains of filler particles are formed even at loadings above the percolation threshold and the composite is intrinsically insulating. However, when subjected to compression the composite becomes conductive, with sample resistance falling from $\geq 10^{12} \Omega$ to $< 0.1 \Omega$. The composite can be formed into insulating granules, which display similar properties to the bulk form. A bed of granules compressed between permeable frits provides a porous structure with a start resistance set by the degree of compression while the granules are free to swell when exposed to volatile organic compounds (VOCs). The granular bed presents a large surface area for the adsorption of VOCs from the gas stream flowing through it. The response of this system to a variety of vapors has been studied for two different sizes of the granular bed and for different matrix polymers. Large responses, $\Delta R/R_0 \geq 10^7$, are observed when saturated vapors are passed through the chemi-resistor. Rapid response allows real time sensing of VOCs and the initial state is recovered in a few seconds by purging with an inert gas stream. The variation in response as a function of VOC concentration is determined.

Keywords: Chemi-resistor, metal-polymer composites, vapor sensing.

*Corresponding author. Tel.: +44(0)191 334 3667; fax: +44(0)191 334 3585.

E-mail address: david.bloor@durham.ac.uk

¹ Present address: Department of Engineering, University of Cambridge, 9 JJ Thompson Avenue, Cambridge, CB3 0FA, UK

1. Introduction

Composites comprising electrically conductive particles, carbon and metal powders, dispersed in an insulating polymer matrix have been studied for over fifty years [1,2]. At low filler content the composite is insulating with an electrical conductivity close to that of the polymer. The resistivity falls rapidly over a narrow concentration range to give a slowly varying resistivity at higher filler concentration. Percolation theory is commonly used to describe the behaviour in the region of rapidly varying conductivity [3]. This model fails at low concentration since it predicts that the composite would have no electrical conduction. Effective medium theories have been developed that provide a good description of the evolution of the conductivity across the full range of filler concentrations [4].

Absorption of organic vapors by composites loaded at or above the percolation threshold leads to swelling of the host polymer and an increase in sample resistance. There have been numerous reports of the use of carbon black composites as chemi-resistors to sense volatile organic compounds (VOCs), see ref. 5 and references therein. While in many instances the response is modest there are examples of very large changes in resistance on exposure to saturated vapors. Increases in resistance by factors of more than 10^6 have been reported. These chemi-resistors use various fillers, e.g. expanded graphite [6], carbon aerogel [7], carbon nanotubes [8], carbon black [9] mixtures of carbon black and nanotubes [10], special polymer matrices, e.g. hydroxyl-terminated polybutadiene [11], or a combination of modified filler and matrix, e.g. vapor grown carbon fibres with surface grafted polymer [12,13]. While the absolute response is large, response times tend to be slow, typically of the order of minutes. A large response can also be obtained by operating the sensor close to or in the percolation regime [14,15]. However, since close to the percolation threshold small changes in filler loading have a large effect on sensor resistance it is difficult to obtain precise and reproducible devices [16]. Practical chemi-resistors have generally been fabricated using commercially available polymers loaded with carbon black at levels above the percolation transition [17]. The swelling of the polymer matrix is greatest when there is a match between the solubility parameter of the polymer and that of the vapor [18]. Hence, chemi-resistors with different polymer matrices will respond

differently to a given VOC and in consequence an array of such sensors will have a response characteristic of the particular VOC. This has been used, together with suitable data analysis, as an electronic nose (artificial olfaction) for the qualitative and quantitative analysis of complex vapor mixtures [19,20,21]. Furthermore, their low fabrication cost, simple device architecture and low power consumption give chemi-resistors a greater suitability and intrinsic scalability for hand-held commercial olfactory applications, when compared to competing detection technologies such as acoustic wave sensors, metal-oxide/semiconductor sensors, photoionisation or mass spectroscopy.

The chemi-resistors described here are based on a new type of composite, which does not conform to the conventional view outlined above of how filler content determines the electrical properties of the composite. It is fabricated by Peratech Ltd., under the generic trade mark QTC™, so that the metal filler particles, which are covered with sharp projections, remain undamaged and are intimately coated by the host polymer [22,23]. Because the particles are separated by the host polymer the as-made composite has a very high resistance, and is effectively insulating at filler to polymer loading ratios of up to 10:1 by weight, which is above the expected percolation threshold. However, the resistance of the composite is extremely sensitive to deformation. Bending, twisting, stretching and compression all result in a reduction in sample resistance [24]. In compression, sample resistance can fall by an extremely large factor, $\geq 10^{14}$ has been observed. This unusual behaviour has been attributed to large electric fields produced by charge concentration at the tips of the sharp projections on the filler particles, which results in charge transport by electric field assisted tunnelling rather than by contact between particles [25]. The unique sensitivity of the Peratech composites to deformation suggest that a similar large response should result from swelling by VOC vapors in a suitably configured composite, which could act as a chemi-resistor. As a secondary advantage, the Peratech composite can also be manufactured in a granular form, offering new porous sensor designs with larger active surface areas. Preliminary data showing large changes in resistance of compressed granular composite on exposure to saturated organic vapors have been reported [24]. The optimisation of the construction and the

properties of porous sensors utilising a granular form of the composites, capable of large fast responses to VOCs, are described in detail below.

2. Experimental

The composite granules comprising nickel powders in different polymer matrices were prepared at Peratech Ltd by patented processes, which involve the careful mixing of nickel powders and liquid pre-polymers [22,23]. Nickel powders were obtained from Inco Ltd. Previous work has illustrated the unique spiky morphology of this nickel powder, which is retained and intimately coated after mixing with the polymer binder [24]. The powders used in this work were type 123 (manufacturer's quoted particle size distribution measured by Fisher sub-sieve sizer from 3.5 to 4.5 μm) and type 287 (quoted particle size in the range 2.6 to 3.3 μm). However, electron microscope observations revealed a somewhat larger size range extending from below 1 μm to above 10 μm . The powders were used as supplied and incorporated in granular powders at metal to polymer loadings of from 88 to 94 wt%. Silicone, urethane and butadiene based pre-polymers were used. These included silicones (Alphasil 2000 (Alphas Industries Ltd.), Silcoset 153 (Ambersil Ltd.), Silastic T4 (Dow Corning)), urethanes (F42 (Techsil Ltd.), Ucecoat DW5661 and 018.B (Cytec Industries Inc.)) and butadiene (Krasol LBH2000, Kaučuk/Sartomer Europe). 18 wt% Silastic T4 was blended with 82 wt% RTV6166 (GE Silicones) to give a softer matrix, referred to herein as Lowmod. Granules were also prepared using a polyvinyl alcohol adhesive. The mixture was prepared, blended and the monomer polymerised following the manufacturer's instructions, to produce granules of controlled size distribution. The composition of most samples used in these studies was 10:1 by weight (1000 phr) metal to polymer, variations from this are noted in the figure captions.

Two flow-through assemblies containing different amounts of granules were used. The larger system, Figure 1(a), consisted of a Perspex cylinder, fitted with two hollow aluminium pistons, Figure 1(b), with the ends covered with a rigid coarse nickel gauze mesh and an outer fine nickel mesh, Figure 1(c). The permeable end-caps act as

filters, allowing gas and vapor to flow through the granules placed between the pistons, and prevent the granules from being flushed out of the sensor unit. The lower piston was fixed and the position of the upper piston was controlled by a screw mechanism. Electrical leads were connected to the two conducting pistons. 3 g of granules were placed in the sample space and compressed until the resistance was in the range from ~ 2 to 50Ω . Resistance data was taken using a Keithley 2000 multimeter. Remote data logging at a rate of 1 reading per second was achieved through a GPIB interface on a PC using LabView software, which also controlled gas streams and flow rates as described below.

This larger volume sensor cell was used with the gas flow apparatus shown in Figure 2. Test vapors were supplied to the sensor unit using filtered ($10 \mu\text{m}$ in-line filter) nitrogen, at a pressure of ~ 2 bar from a liquid nitrogen boil-off source, as a carrier gas. Two lines of carrier gas were fed through two regulating control valves. One line was then split into two paths with remote control of the flow rate with Cole-Parmer model U-32708-20 mass flow controllers (MFCs) with a flow capacity range of 0 to 50 ml/min. The MFCs were connected to the PC via a 12 bit digital to analogue converter and flow rates were logged via a 12 bit analogue to digital converter. The gas from one MFC was passed through glass bubblers and liquid traps to provide a liquid-free flow saturated with test vapor. The bubblers were immersed in a variable temperature bath filled with Baysilone M3 silicone fluid and fitted with a Grant LTC20-40RS low temperature circulator capable of temperatures in the range -55 to $+100$ °C. The gas from the second MFC was used to dilute the saturated gas flow. Concentration of the test vapor was controlled by varying bubbler temperature and mixing ratio of the two gas streams.

The diluted gas stream was connected to one input of an Omnifit 11500 four-way electric solenoid rotary valve. High flow rate purge gas, provided by the second nitrogen gas line, was connected to the second input. Purge flow rates below 50ml/min were monitored using a Cole-Parmer U-32707-22 mass flow meter. High pressure purging gave flow rates >50 ml/min. The remaining two ports were connected to an exhaust and to the sensor cell enabling the sensor to be either exposed to solvent

vapor, or purged with nitrogen. Switching of this valve was controlled by the LabVIEW programme.

The equipment described above was modified to accommodate smaller sensor cells and to provide a more stable environment for the sensors. This was necessary as the resistance of compressed granules was affected by changes in ambient temperature and in gas pressure when the gas flow was switched. The sensor cells had a similar construction to the large cell, but were much smaller accepting 10 to 50 mg of granules. The nickel frits were replaced by stainless steel frits that did not require additional support. Ten of the smaller cells were mounted in parallel inside an LMS Series 1 Model 305 cooled incubator that provided a temperature stable to ± 0.2 °C. The temperature of the test and purge gas flows were equalised with that of the sensors by passing them through ~10 m of PTFE tubing immersed in an oil bath placed in the incubator. Nagano Keiki Seisakusho ZT17 gas pressure sensors were inserted in the sensor and purge lines, and the analogue output from the sensor meter was connected to the PC via the 12 bit analogue to digital converter. The purge gas flow rates were monitored with a mass flow meter with an upper limit of 100 ml/min and adjusted by a flow restrictor. The temperature of the source bath and incubator were measured with platinum resistance thermometers and the temperatures of the ten sensors monitored with thermistors. The resistances of the ten sensors were measured using two Keithley 2701 multimeters, each fitted with 20-channel 7710 cards and interfaced to a PC via a 10/100 ethernet card set to 100 Mbit/s. As each resistance measurement required 20 ms to execute, and with five sensors connected to each multimeter, ten measurements per second were possible for each of the ten sensors. Automatic collection of temperature, flow and resistance data was realised with a modified LabVIEW programme.

3. Results and discussion

3.1 Large volume chemi-resistors

Using the large volume sensor cell, granules prepared with silicone (Dow Corning Silastic T4), polyurethane (Techsil F42), PVA and polybutadiene were exposed to ethanol, hexane, tetrahydrofuran (THF) and water vapors. After compression of the granules to achieve a starting resistance, the composite was allowed to relax until a stable resistance value was reached, typically this required 15 min. The granules were then exposed to nitrogen saturated with vapor at room temperature, ~ 20 °C, flowing at 50 ml/min. After exposure the sensor was purged using nitrogen at an inlet pressure of 2 bar, which gave a flow rate greater than the 50 ml/min upper limit of the flow meter. Subsequent use of a flow meter with a larger range indicated that the flow rate would have been ~ 100 ml/min under these conditions. Two sequences of exposure and purge were used, (a) 1 min exposure followed by a purge of 1 to 5 min duration, and (b) exposure long enough to reach a limiting value of sensor resistance with purge long enough to return the sensor close to its original resistance.

The limiting responses of silicone granules exposed to hexane and of polyurethane granules exposed to THF are shown in Figures 3(a) and (b) respectively. In both cases the final resistance is the upper limit set by the measurement range of the multimeter. This limit was reached in ~ 100 s for the silicone and ~ 300 s for the polyurethane, see inserts in the figures. Figure 3(c) shows the much smaller and slower response of silicone granules to saturated ethanol vapor. The flow during exposure was 50ml/min and >50 ml/min during purging giving recovery noticeably faster than the initial response. After purging the sensor, subsequent long exposures are similar to those shown in Figure 3.

The response of polyurethane granules to repeated short exposures to 105,200 ppm THF vapor with exposure and purge flow rates of 25 ml/min is shown in Figure 4. The sensor was purged for 5 min between each exposure. Under these conditions the initial response was faster than the recovery. This is evident in the figure and in the insert showing a single cycle on an expanded timescale. The response is reduced tending towards a limiting value over thirty exposures. This is attributed to the relaxation of the random bed of compressed granules in response to the repeated swelling and contraction until it reaches an equilibrium configuration. As shown in the insert, the sensor reacts to the vapor within a few seconds of the onset of exposure

and has a faster response at the onset of the purge followed by a slower recovery. Similar asymmetric response to exposure and purge is observed for all the test vapors. In contrast for short exposures of silicone granules with the same exposure and purge flow rates the purge is more rapid with the resistance falling to close to the initial value in less than 10 s, consistent with the results for extended exposure (Figure 3(a)). The reduction in response of silicone granules on repeated exposure occurs in less than ten exposures and is more pronounced than for the polyurethane granules.

A summary of the observed responses in terms of the fractional change in resistance is given in Table 1. Where a range of values is quoted for short exposure times the larger value is for the first exposure and the smaller is for the stable response after repeated exposures, c.f. Figure 4. Large limiting responses are observed for silicone granules exposed to hexane and polyurethane granules exposed to THF and ethanol. Those observed for the PVA granules were smaller and no measurable response was obtained for the polybutadiene granules for any vapor. The response of the silicone granules to water vapor was very low. That for the polyurethane granules was larger, and a limiting value was only reached after 40 min exposure, but still much smaller than the response to the organic vapors. Long exposure of the PVA granules to water vapor resulted in degradation of the composite and a noisy and irreversible response. Although a large response was observed for PVA granules exposed to THF the response was extremely slow, requiring 70 min to reach a limiting value of resistance.

An experiment was conducted utilising a picoammeter to assess the dynamic range of a silicone granule sensor exposed to hexane. The measured fractional change in the resistance ($\Delta R/R_0$) is shown in Figure 7. In this instance the initial resistance was set at the higher value of 525 Ω . The measurement limit of the picoammeter (equivalent to 10^{12} Ω) was reached after ~ 90 s. The initial value of $\Delta R/R_0$ of 5×10^{-2} was set by instrumental noise as was the upper value, which is $> 10^8$, Figure 5. This data is indicative of a dynamic range of $\sim 10^{10}$. This is physically reasonable given that a change in resistance greater than 10^{14} has been observed for bulk composite under compression [25].

3.1.1 Sensitivity to organic vapors

The responses of the granules as a function of vapor concentration were determined for polyurethane granules exposed to THF and for silicone granules exposed to hexane. Data for the former, comprising the average response for series of thirty 1min exposures and the limiting response for long single exposures, are shown in Figure 6(a). The average response of the silicone granules to hexane showed greater variation, Figure 6(b). However, the dependence of response on vapor concentration is similar for both matrices. The increase in response with increasing vapor concentration is more marked for the long exposure data shown in Figure 6(a). This is indicative of different underlying mechanisms at low and at high vapor concentration. At low concentrations, filling of the nano-pores in the polymer matrix will result in a change in dielectric constant [26,27,28]. This will affect the field induced emission from the sharp features on the surfaces of the filler particles, but there will be little swelling [29]. At high vapor concentrations, swelling will be the predominant factor affecting sensor resistance. This hypothesis is being investigated through more detailed studies of the response of stand-alone sensors, which will be reported in a further publication.

The differential response of chemi-resistors with different polymer matrices to different vapors is employed in sensor arrays to differentiate chemical components in mixtures [30,31,32]. The differential response reflects the difference in solubility parameters between the solvents and the polymers [33]. Whilst the solubility parameters of solvents and linear polymers are known, those of cross-linked elastomers are less well defined [34]. Values for the Hildebrand parameter for silicone polymers lie in the range 14 to 19 MPa^{1/2}, with experimental and theoretical values for poly(dimethyl siloxane) of 14.9 and 15.6 MPa^{1/2} respectively [35,36]. Values of the parameter for polyurethanes are cited in the range 20 to 21 MPa^{1/2}.³² The heat of mixing of polymer and solvent is proportional to the parameter $(\delta_1 - \delta_2)^2$, where δ_1 and δ_2 are the solubility parameters for the solvent and polymer respectively. This quantity characterises the solubility of the polymer in the solvent, i.e. it must be small if the polymer and vapor are to be miscible over a wide range of volume fractions of the components [33]. $(\delta_1 - \delta_2)^2$ and the relative responses, $\Delta R/R_0$, for long exposures of silicone and polyurethane granule sensors to hexane, THF, ethanol and water are

listed in Table 2. Based on available data δ_2 was taken to be $15 \text{ MPa}^{1/2}$ for the silicone granules and $20.4 \text{ MPa}^{1/2}$ for the polyurethane granules. Table 2 indicates the difference in response of the two matrices and that there is a better correlation between sensor response and the parameter $(\delta_1 - \delta_2)^2$ for the silicone matrix.

3.2 Small volume chemi-resistors

A greater variety of matrix polymers were studied using the small volume sensor cell. Fast, large responses were observed for a variety of polymer matrices and vapors, e.g. Figures 7-11. Both response and recovery are rapid; the speed and reproducibility of responses are discussed below. In general, the sensor recovers to a different resistance from that initially set by the compression of the granules. After the first exposure, this can be either less or greater than the initial value and can either increase or decrease gradually upon repeated exposures, c.f. Figures 7 and 10. The response is reduced as the vapor concentration is reduced, Figure 8, following the same trend seen with the large volume cell, Figure 6(a). Both the Silastic and Silcoset matrix granules give a larger response in the small volume cell than was seen with the Silastic matrix in the large volume cell. For the Silcoset matrix $\Delta R/R_0$ is $> 10^6$ at 104,350 ppm and ~ 1.5 at 525 ppm for the small volume cell, compared with values for the Silastic matrix of 10^2 and 5×10^{-3} at similar concentrations for the large volume sensor (Figure 6(b)). Similarly, the response of the Silastic matrix to 127,000 ppm hexane is $> 10^7$ (Figure 7). Data for different polymer matrices and vapors are summarised in Table 3.

Other factors that were found to affect sensor response were the filler loading, the mass of granules used and the initial resistance set by compression. The results for sensors containing Silcoset granules with a Ni loading of 88 wt% and granule masses of 10, 20 and 30 mg are shown in Figure 9. The response increases as the mass is increased to 30 mg, the maximum quantity that could be loaded into the small volume cell. As the Ni loading of the granules is increased there is a trend towards a reduced response. However, this is a qualitative result because of variability in the number of granules in the cell at the low masses employed.

A series of simultaneous measurements were made with ten sensors prepared, with Silcoset 88 wt% Ni granules, to be as similar as possible and set to initial resistances of 5.2 (± 1.0), 9.9 (± 1.2) and 97 (± 3) Ω . The responses of three of the ten sensors to repeated exposures to saturated hexane vapor for each of these initial resistance settings are shown in Figure 10. Reorganisation of the granules occurs as a result of the repeated swelling and contraction, with a consequent change in baseline resistance. After ten exposures and purges the measured resistances were 4.3 (± 0.8), 8.6 (± 1.5) and 50.6 (± 15) Ω . The greatest change, with a widest variation in values, was for the least compressed sensors, which would have more free space and more freedom for reorganisation. Whilst in this instance the overall baseline resistances fell, in general both increases and reductions in resistance were seen after the initial exposure. The rapid scanning of the ten sensors required a short measurement time and limited the maximum measurable resistance to 1 M Ω . This can be seen in Figure 11, which shows the overlaid responses for the last five vapor exposures for three of the sensors with initial resistances ~ 100 Ω . The overlaid data shows good reproducibility and rise times to the upper limit of resistance measurement are in the range 4 to 12 s. As the ten sensors are subject to the same drop in gas pressure the likely cause of these differences in response times is the variation in the small mass of granules in each sensor and the degree of compression, which result in differences in the resistance to flow through them and hence in flow rates. Similar rapid responses were observed for initial resistances close to 5 and 10 Ω . There is an initial slow increase in resistance followed by an exponential growth, shown by the straight lines added to Figure 11. Similar responses of elastomer/carbon black composites on exposure to saturated vapors have been reported [37,38]. This was interpreted in terms of the swelling of the polymer matrix [38]; however, this implies a uniform swelling of the composite. While this may be possible for the small granules employed in this work it seems unlikely for the bulk composite used in ref. [38].

4. Conclusions

The compressed composite granules offer a large surface area and porous medium for the gas flowing through the chemi-resistors. The surfaces of the granules, in particular the contacts between granules, will have the highest concentration of absorbed VOCs

and will be the most affected by them. At low vapor concentrations the sensor response is slowly varying as the concentration is increased. We have attributed this behaviour to changes in dielectric constant consequent to pore filling by the VOC, which affects the electric field-induced tunnelling from the sharp surface features on the filler particles. This possibility is being investigated further and will be revisited in the following publication. At high vapor concentration the sensor response varies more rapidly with concentration. Comparison with other studies indicates that in this region the response is primarily due to polymer swelling. This results in a large increase in sensor resistance as the separation of the filler particles increases. There is no evidence of increased resistance to gas flow, so the swelling does not have a significant effect on the porosity of the granule bed. Thus, there is ample free space in the chemi-resistor to allow unconstrained swelling. Although the overall gas flow rate is modest, that through the channels in the granule bed will be much larger. One consequence of this is the rapid recovery observed on purging even after exposure to high concentrations of analyte.

As expected, the response of the chemi-resistors is largest when there is a match between the solubility parameters of the analyte and the matrix polymer. The very large increase in resistance caused by matching analytes indicates that the degree of swelling is also large. The granular beds are randomly packed so there will be a complex stress distribution within the bed. In addition it is likely that there will be residual internal stress within the granules. The rapid swelling and contraction produced by saturated vapors will affect the arrangement of the granules and the stress distribution within the bed and the granules. Two consequences of these relaxation processes are observed. The first is a change in the initial resistance, which can be either an increase or decrease, and the second is a reduction in response. Similar effects have been observed in other chemi-resistors [10-14,39]. The granular chemi-resistor responses change most rapidly for the first few exposures to the analyte vapor, and tend towards a stable response after about ten repeated exposures.

When exposed to saturated vapors the large volume chemi-resistors were relatively slow to reach a limiting resistance, but measurable responses ($\Delta R/R_0 > 1$) were obtained in less than 30 s. The small volume chemi-resistors had much faster

responses, with values of $\Delta R/R_0 > 10^4$ being reached in a few seconds, and with a close to exponential increase in resistance. Temporal responses of the order of seconds have previously been reported for carbon black/polymer chemi-resistors by utilising short analyte pulses with flow rates in the range 500 to 1500 cm/sec [40]. An exponential growth in response was also observed. As noted above, the localised flow rate of the gas stream through the channels in the granule bed will be larger than the overall flow rate. This is probably a contributory factor to the fast response of the small volume chemi-resistors.

Research has continued into stand-alone sensors incorporating composite granules, which do not require the application of an external force to obtain a low starting resistance, and will be reported in Part 2.

In summary, we present data for a new and high-performing chemi-resistive vapor detection sensor. The unique and highly sensitive material from which the sensors are fabricated offer greatly improved sensitivity to analytes compared to conventional chemi-resistor technologies. Furthermore, their porous structure gives rise to improvements in response and recovery times. These sensors are simple in design, are air-stable, have negligible response to humidity (for silicone binders), have low power consumption, and are highly scalable for manufacture. It is envisaged that such technology will enable a new range of low-cost, portable qualitative and quantitative chemical vapor detectors to be realised.

5. Acknowledgements

The EPSRC is thanked for a grant in aid of part of this work and for a postgraduate studentship for P.J.W. Hands. Data on the small volume sensors was provided E.J. Williams, who also received support from EPSRC. Thanks are also due to K.P. Donnelly for his assistance in the automation of experimental apparatus, and to M. Noble for measurements taken during his final year undergraduate project. Funding for equipment was provided by the Higher Education Innovation Fund (HEIF2) via the Partnership Venture Fund.

Figure Captions

- Figure 1 (a) Large volume flow-through sensor cell, (b) component parts of the cell and (c) permeable piston.
- Figure 2 Experimental apparatus used with the large volume cell, showing gas flow paths and electrical connections.
- Figure 3 Response of granules in the large cell for (a) Silcozet 153 matrix/Ni 123 exposed to hexane vapor, (b) Techsil F42 matrix/Ni 123 exposed to THF vapor and (c) Silcozet 153 matrix/Ni 287 exposed to ethanol vapor. 50ml/min flow of vapors saturated at room temperature. Inserts in (a) and (b) show the increase in resistance on exposure on an expanded time scale.
- Figure 4. Response of granules in the large cell; Techsil F42 matrix/Ni 123 for repeated short exposures to 25 ml/min flow of THF vapor saturated at 10 C (105,200 ppm). Insert shows a single exposure on an expanded time scale.
- Figure 5. Relative response of granules in the large cell recorded with a Keithley Picoammeter for Silastic T4 matrix/Ni 123 exposed to 50ml/min flow of hexane vapor saturated at room temperature.
- Figure 6. Variation in response of granules in the large cell as a function of vapor concentration for (a) Techsil F42 matrix/Ni 123 for THF vapor with both extended exposure (■) and the average of 30 short exposures (▲) and (b) Silastic T4 matrix/Ni 123 for hexane vapor, averaged over 30 short exposures.
- Figure 7. Response of granules in the small cell; 20 mg of Silastic T4 matrix/Ni 123 for repeated 1 min exposures to 127,000 ppm hexane vapor.
- Figure 8. Response of granules in the small cell; 15 mg Techsil F42 matrix/Ni 123 for THF vapor at 134,000 ppm (solid line), 62,660 ppm (dash line) and 26,250 ppm (dotted line).
- Figure 9. Response to saturated acetone vapor of Silcozet granules with a Ni 123 loading of 88 wt% in the small cell with sensor masses of 10 mg (solid line), 20 mg (dashed line), and 30 mg (dotted line).

Figure 10. Response of sample small cell sensors from the Silcoset 88 wt% Ni 123 ten sensor arrays for exposure to hexane vapor saturated at 20 °C, (a) initial resistances $\sim 5 \Omega$, sensors 2, 5, and 10; (b) initial resistances $\sim 10 \Omega$, sensors 1, 6, and 10; (c) initial resistance $\sim 100 \Omega$, sensors 1, 6, and 9.

Figure 11. Temporal responses of sample small cell sensors from the Silcoset 88 wt% Ni 123 ten sensor array with initial resistances $\sim 100 \Omega$, sensors 1 (\square), 6 (Δ) and 2 (\circ), on exposure to saturated hexane vapor. Data from successive exposures is overlaid.

Tables

Table 1

Measured fractional changes in resistance ($\Delta R/R_0$) of large volume sensors for different vapor-matrix polymer combinations.

Vapor	Exposure	Matrix polymer			
		Silicone Silastic T4	Polyurethane Techsil F42	PVA	Polybutadiene Krasol LBH2000
Ethanol	30 s	$1.1 \times 10^{-3} - 4.4 \times 10^{-2}$	0.167	3×10^{-2}	No response
	60 s	$3.6 \times 10^{-2} - 0.25$	0.811	9.7×10^{-2}	
	Limiting	6.3	1.2×10^6	$> 4.8 \times 10^4$	
Hexane	30 s	4.5 – 15	280	1.2×10^{-2}	No response
	60 s	27 – 700	$> 4.5 \times 10^4$	3.2×10^{-2}	
	Limiting	$> 7.5 \times 10^8$	$\gg 4.5 \times 10^4$	1.6	
THF	30 s	0.19 – 4.7	0.12 – 1.7	$6.2 \times 10^{-2} - 1.8$	No response
	60 s	0.73 – 72	1.3 – 6.4	3.95	
	Limiting	6.3×10^3	$> 1 \times 10^7$	$> 3.3 \times 10^4$	
Water	30 s	$0 - 1.5 \times 10^{-3}$	0	0	No response
	60 s	$5 \times 10^{-3} - 9.8 \times 10^{-3}$	$8.7 \times 10^{-3} - 5.5 \times 10^{-2}$	$1 \times 10^{-2} - 3.8 \times 10^{-2}$	
	Limiting	3.1×10^{-2}	2.15	-	

Table 2

Correlation of relative response with solubility parameter difference for Silastic T4 matrix/Ni 123 granules, ▲, and Techsil F42 matrix/Ni 123 granule, ●, in the large cell.

Silastic T4/Ni 123				
Vapor	Hexane	THF	Ethanol	Water
$(\delta_1 - \delta_2)^2$ (MPA)	0.04	11.6	123	1076
$\Delta R/R_0$	1×10^9	6300	6.3	0.03
Techsil F42/Ni 123				
Vapor	THF	Ethanol	Hexane	Water
$(\delta_1 - \delta_2)^2$ (MPA)	4	32.5	31.4	751
$\Delta R/R_0$	1×10^7	1.2×10^6	45000	2.2

Table 3

Maximum values of the fractional changes in resistance ($\Delta R/R_0$) and times to reach the maximum response for small volume sensors with different vapor-matrix polymer combinations.

Vapor	Matrix polymer	Experimental conditions			
		Vapor concentration (ppm)	QTC granule mass (mg)	Response time (s)	$\Delta R/R_0$
Ethanol	DW5661	45,000	24	~ 60	$> 10^6$
	018.B	45,000	28	~ 60	55
	Techsil	31,000	20	~ 60	$> 5 \times 10^6$
	Silcoset	57,000	10	~ 30	7
	Lowmod	57,000	20	~ 30	0.6
Hexane	DW5661	127,000	10	~120	100
	018.B	127,000	20	~30	50
	Techsil	127,000	20	~ 10	$> 10^6$
	Silcoset	160,000	15	< 10	$> 3 \times 10^6$
	Lowmod	127,000	20	~ 10	$> 2.5 \times 10^8$
THF	DW5661	135,000	18	~ 10	$\sim 10^6$
	018.B	135,000	15	< 10	$> 10^6$
	Techsil	135,000	15	< 10	$> 10^6$
	Silcoset	135,000	15	~10	$> 10^6$
	Lowmod	135,000	20	< 10	$> 10^6$
Acetone	DW5661	194,000	26	<10	$> 10^6$
	018.B	194,000	20	< 10	$> 10^6$
	Techsil	194,000	15	~ 20	$> 10^6$
	Silcoset	194,000	25	~ 40	$\sim 2 \times 10^4$
	Silastic	194,000	25	<20	$> 10^6$
	Lowmod	194,000	20	~40	$\sim 4 \times 10^4$
Water	DW5661	17,130	25	~480	0.05
	018.B	17,130	15	~120	~0.8
	Techsil	17,130	15	~600	~1
	Silcoset	17,130	18	-	No response
	Lowmod	17,130	10	-	No response

Fig. 1

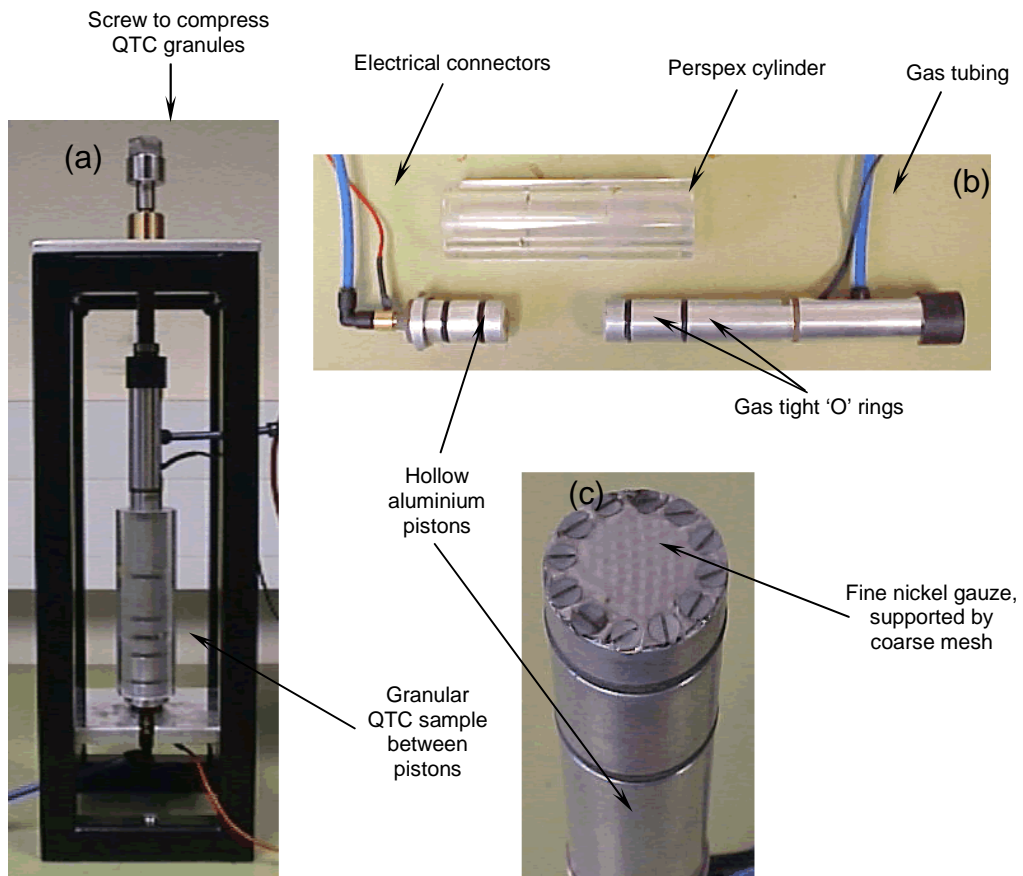

Fig. 2

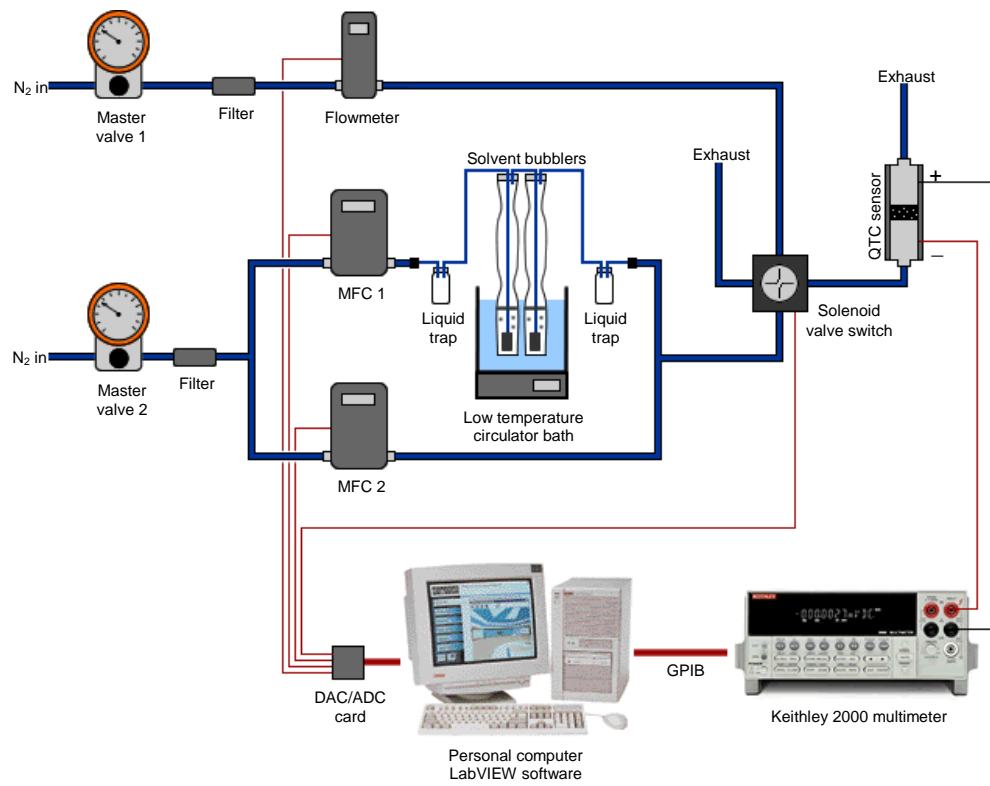
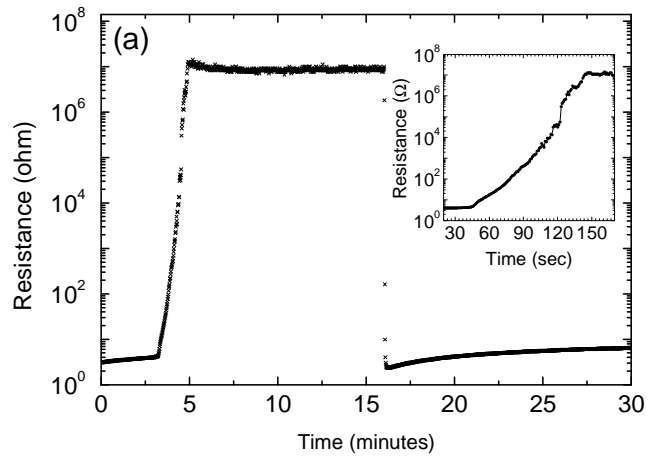
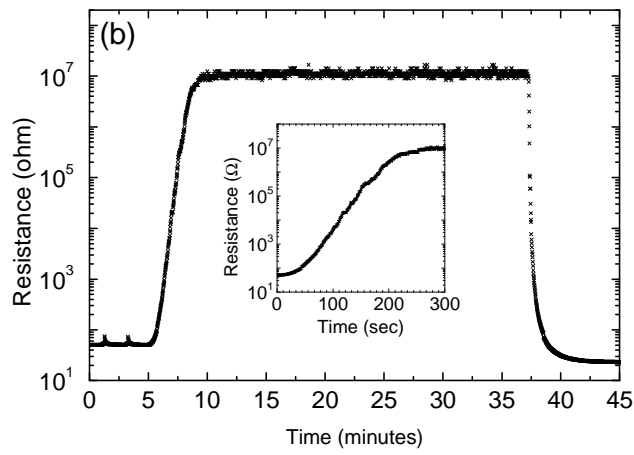

Fig. 3

(a)



(b)



(c)

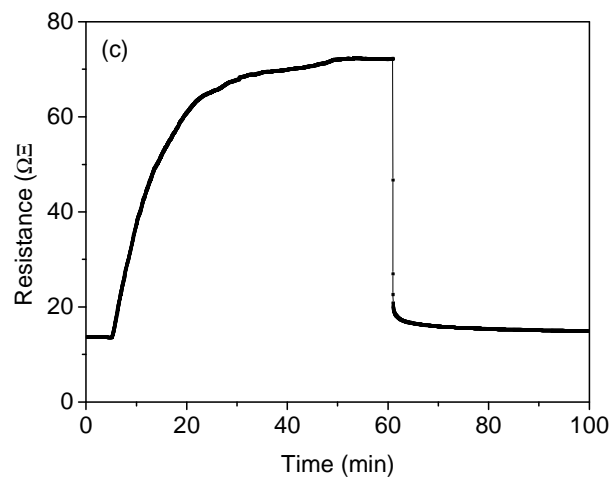

Fig. 4

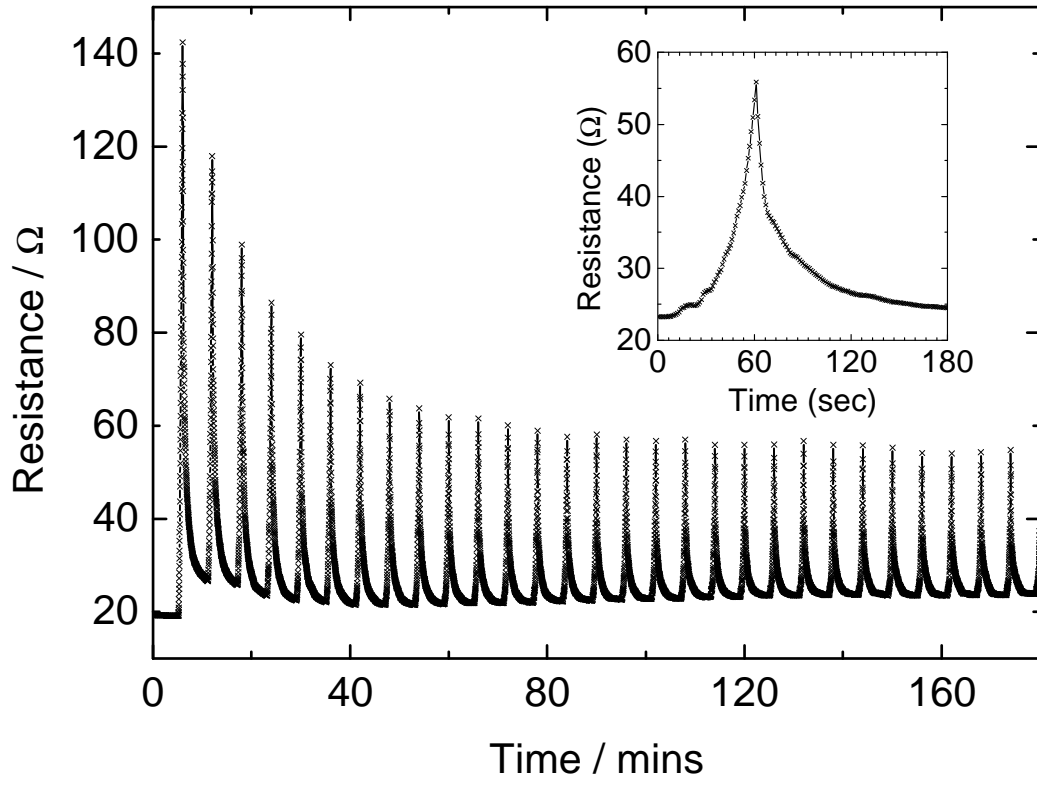

Fig. 5

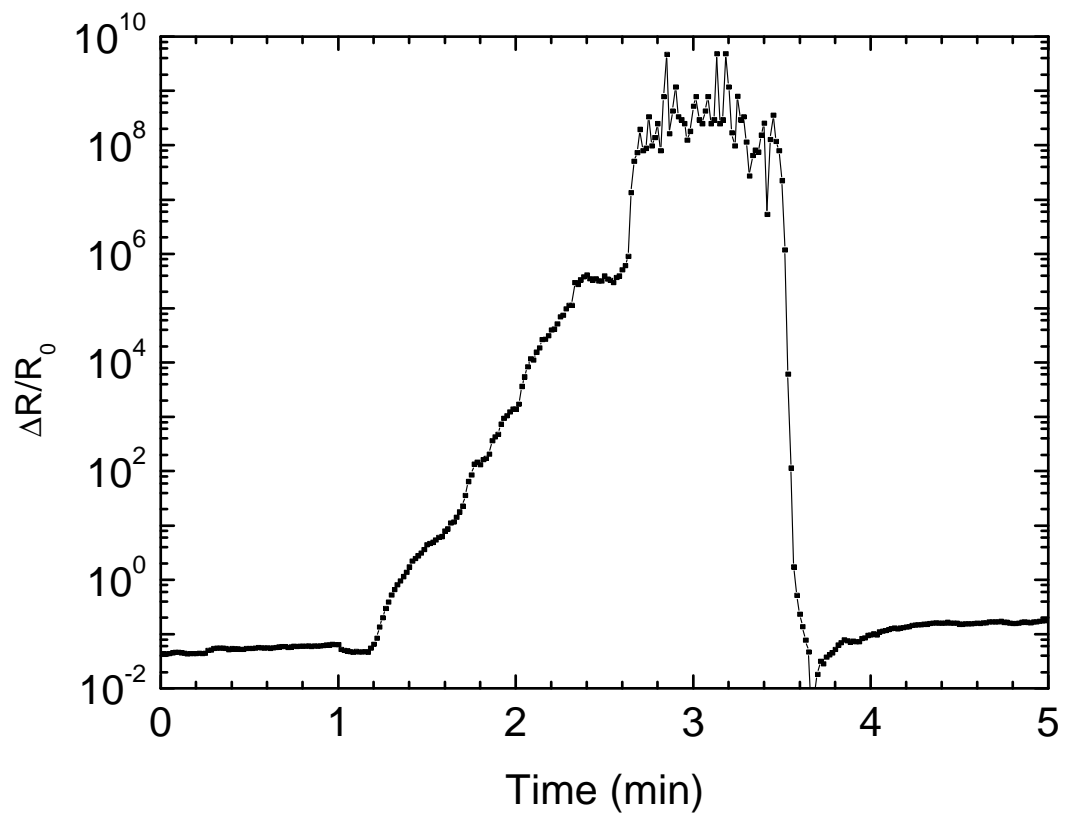
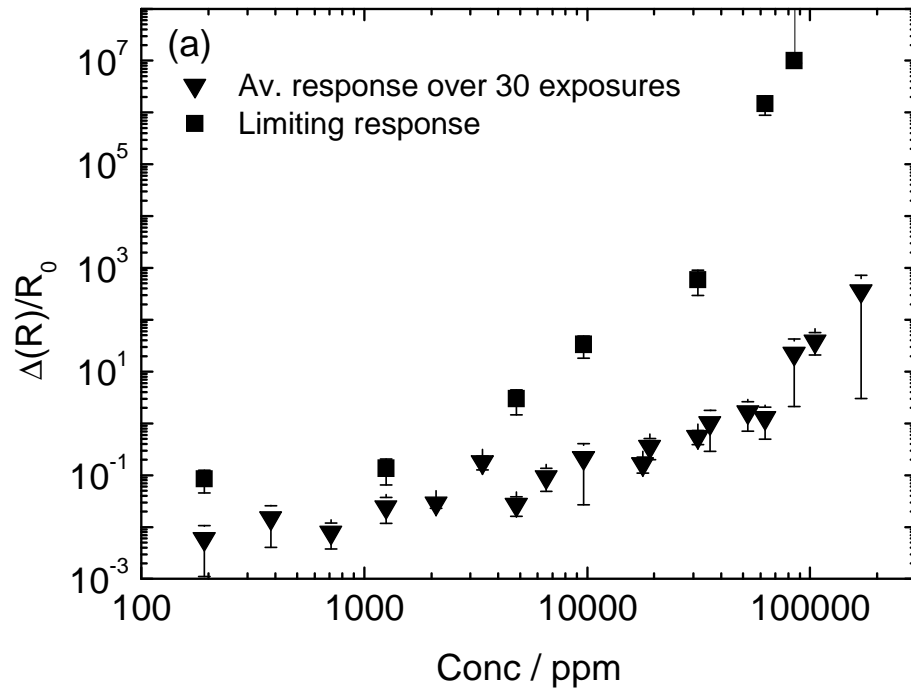

Fig. 6

(a)



(b)

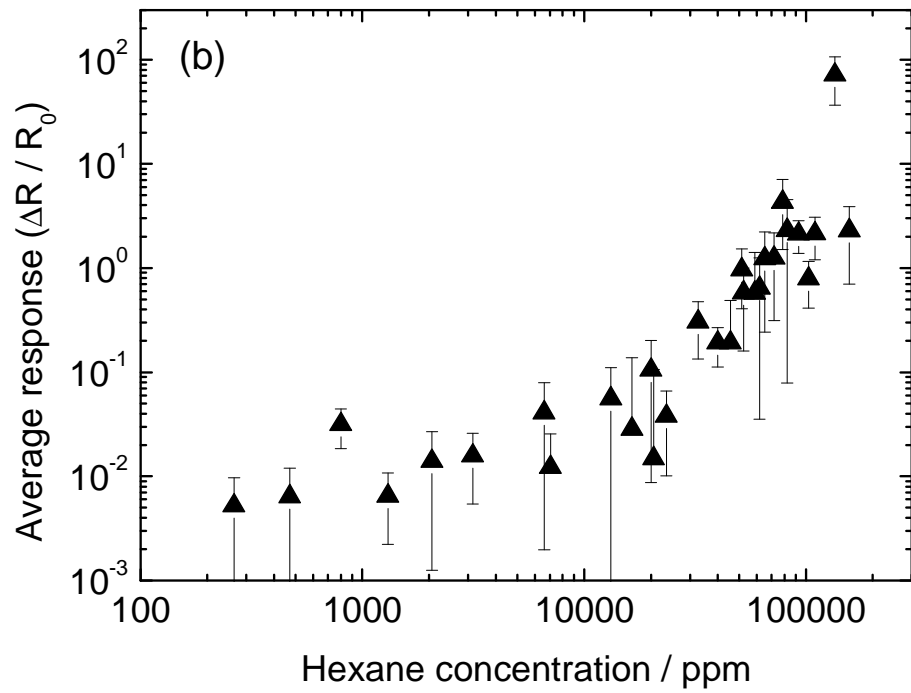

Fig. 7

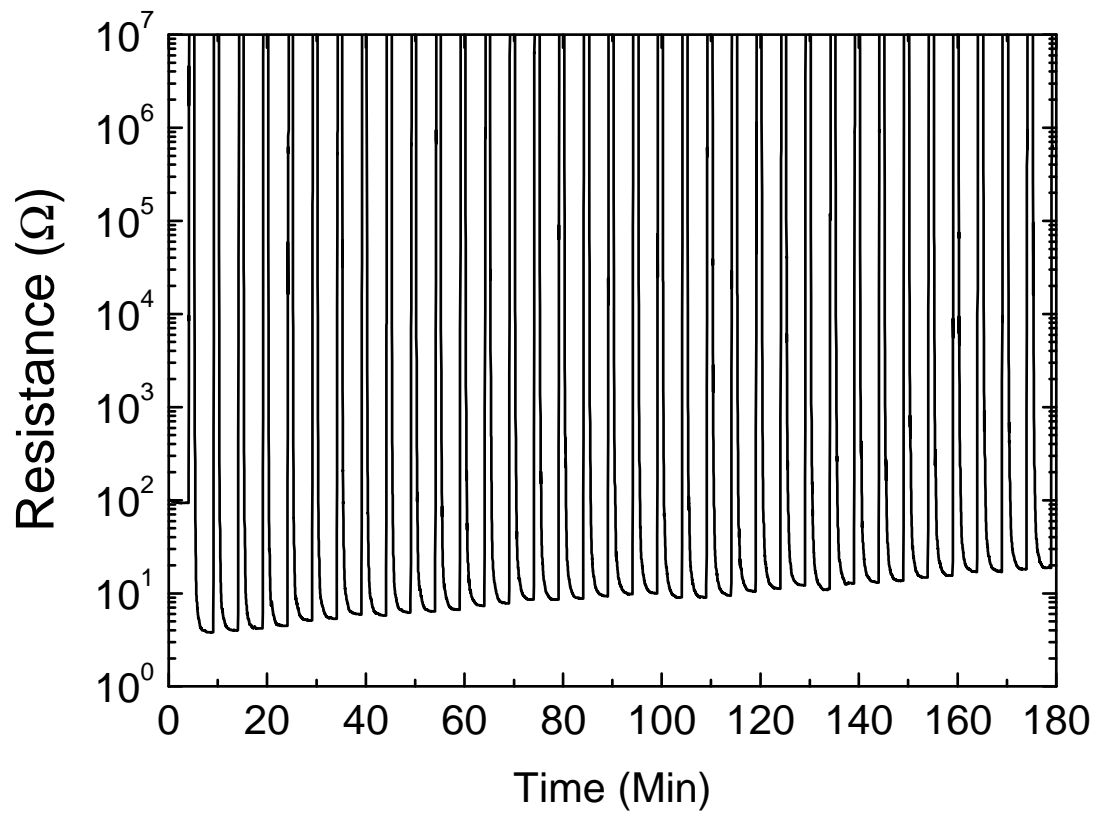

Fig. 8

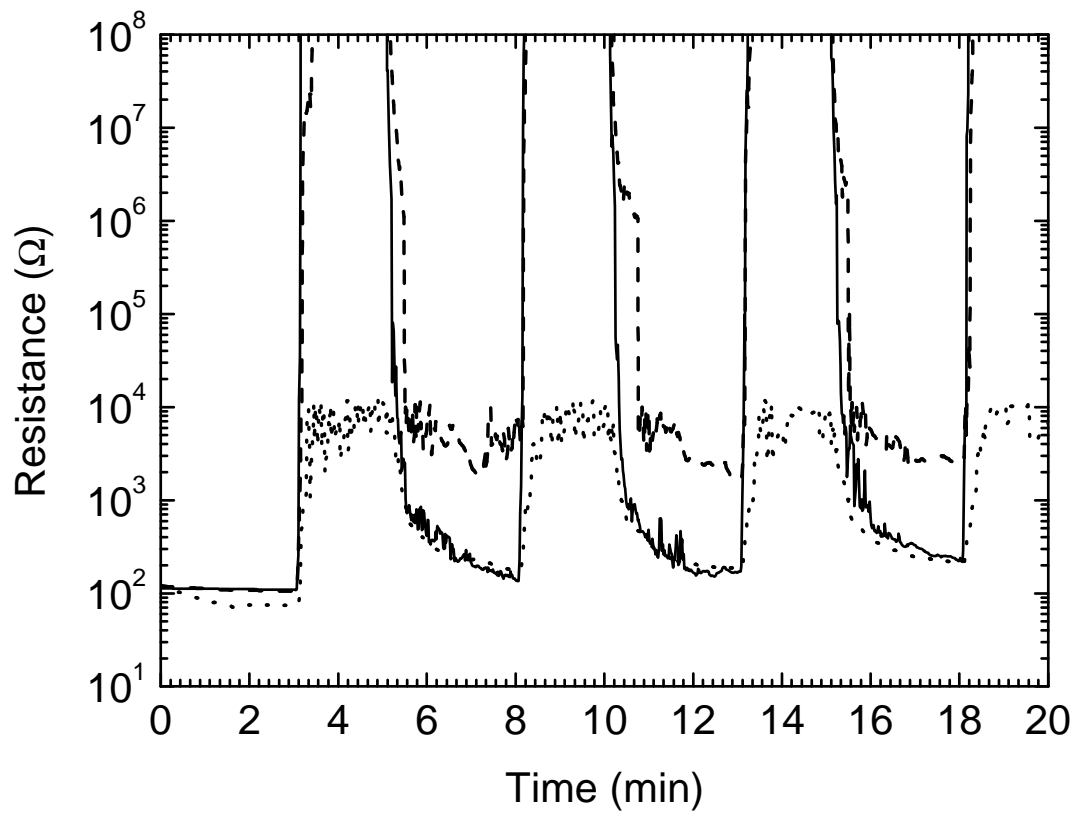

Fig. 9

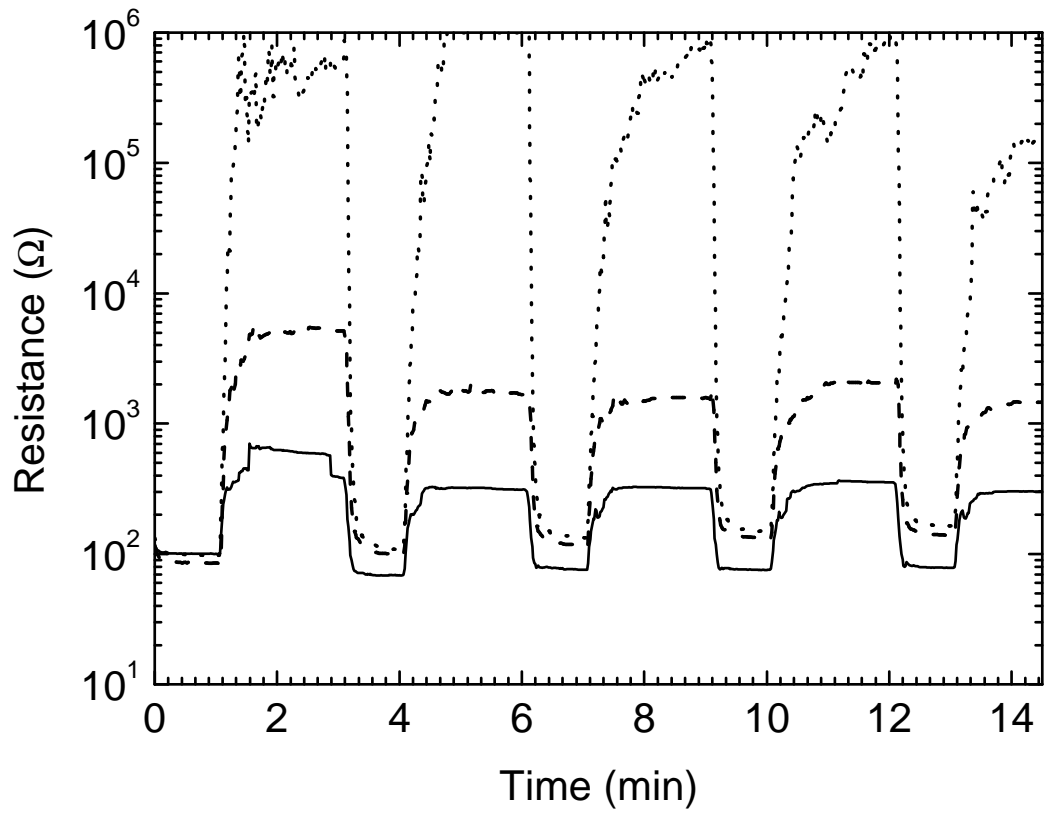

Fig. 10

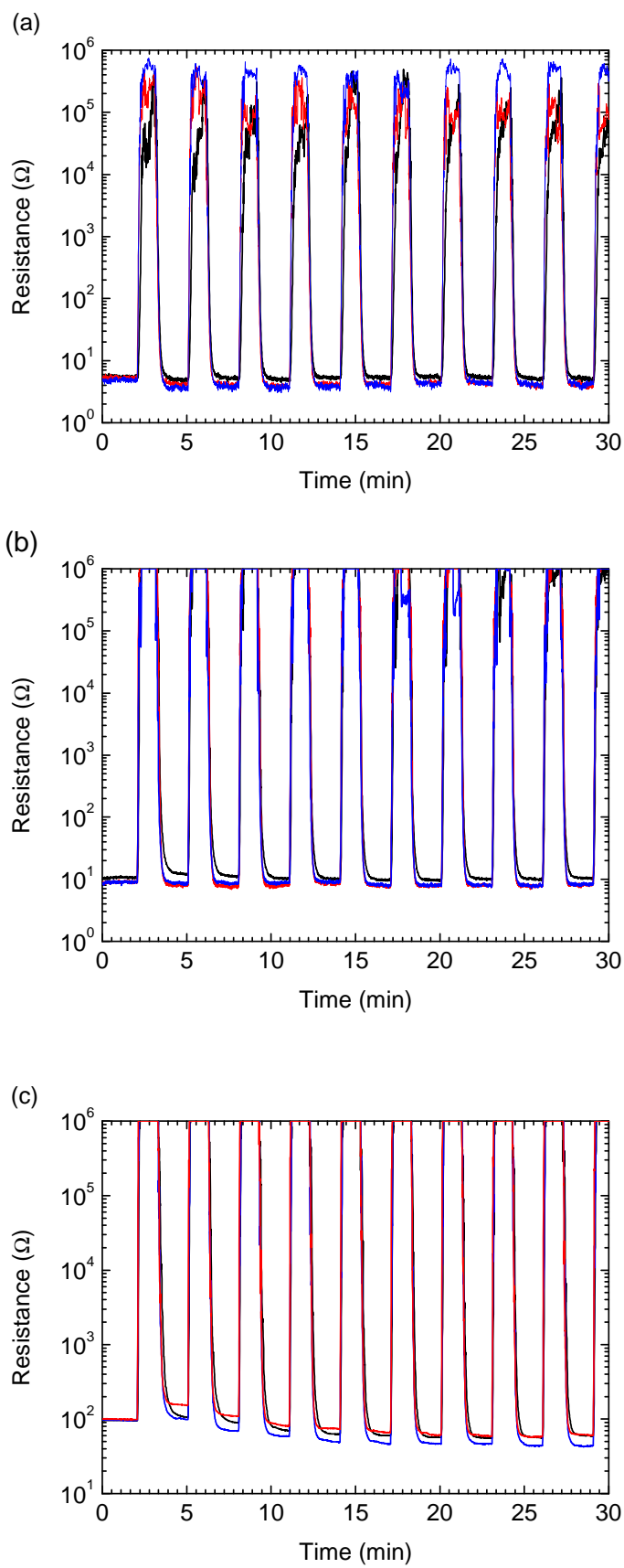
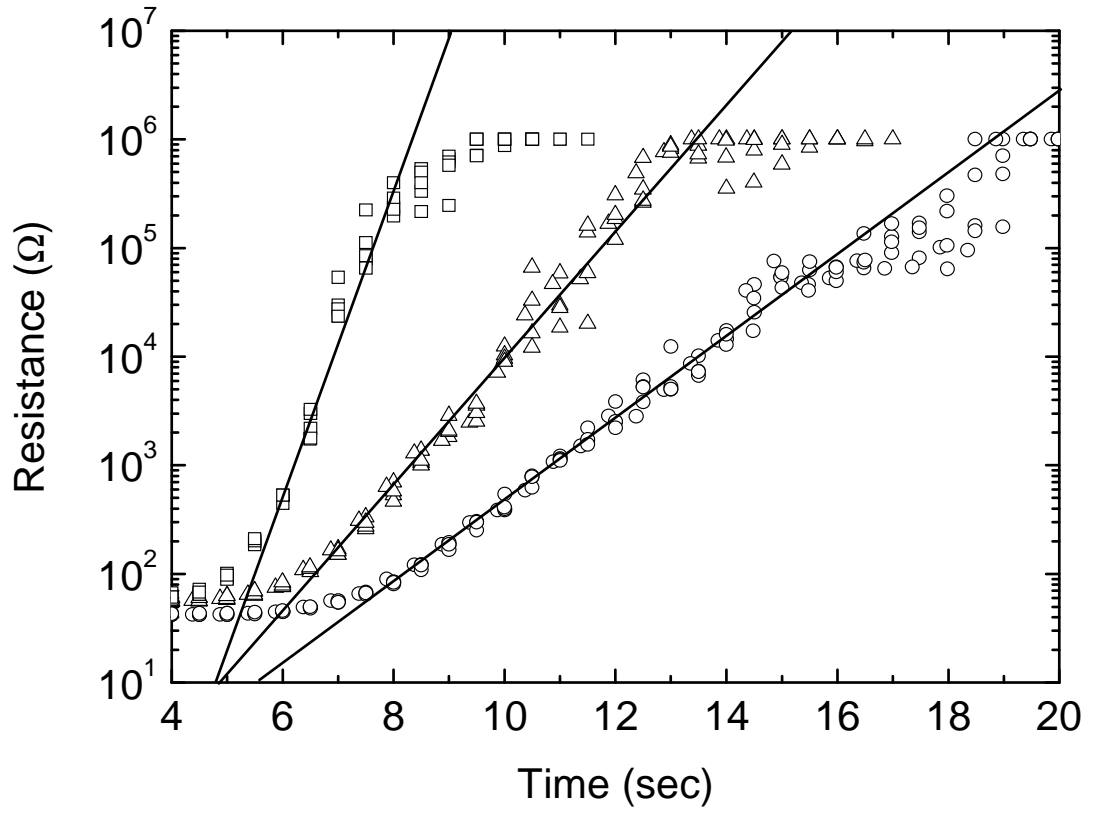

Fig. 11



References

- 1 R.H. Norman, *Conductive Rubber*, Maclaren, London, 1957.
- 2 V.E. Gul', *Structure and Properties of Conducting Polymer Composites*, VSP, Utrecht, 1996.
- 3 F. Carmona, *Conducting filled polymers*, *Physica A* 157 (1989) 461-469.
- 4 D.S. McLachlan, *Analytical functions for the dc and ac conductivity of conductor-insulator composites*, *J. Electroceram.* 5:2 (2000) 93-110.
- 5 H. Lei, W.G. Pitt, L.K. McGrath, C.K. Ho, *Modeling carbon black/polymer composite sensors*, *Sens. Actuators B - Chem.* 125 (2007) 396-407.
- 6 L. Li, Y. Luo, Z. Li, *The preparation and vaporvapor-induced response of a conductive nanocomposite based on poly(methyl acrylic acid)/expended graphite by in situ polymerization*, *Smart. Mater. Struct.* 16 (2007) 1570-1574.
- 7 B. Zhang, X. Dong, W. Song, D. Wu, R. Fu, B. Zhao, M. Zhang, *Electrical response and adsorption performance of novel composites from polystyrene filled with carbon aerogel in organic vapors*, *Sens. Actuators B - Chem.* 132 (2008) 60-66.
- 8 B. Zhang, X. Dong, R. Fu, B. Zhao, M. Zhang, *The sensibility of the composites fabricated from polystyrene filling multi-walled carbon nanotubes for mixed vaporvapors*, *Comp. Sci. Technol.* 68 (2008) 1357-1362.
- 9 J. Lee, J. Choi, J. Hong, D. Jung, S.E. Shim, *Conductive silicone/acetylene black composite films as chemical vaporvapor sensors*, *Synth. Metals* 160 (2010) 1030-1035.
- 10 B. Zhang, R. Fu, M. Zhang, X. Dong, B. Zhao, L. Wang, C.U. Pitman Jnr, *Studies of the vaporvapor-induced sensitivity of hybrid components fabricated by filling polystyrene with carbon black and carbon nanofibers*, *Composites: Part A* 37 (2006) 1884-1889.
- 11 Y. Luo, Y. Li, Z. Li, *Investigation of the vaporvapor sensing behaviour and mechanism of a reactive hydroxyl-terminated polybutadiene liquid rubber/carbon black conductive film*, *Smart. Mater. Struct.* 15 (2006) 1979-1985.
- 12 L. Niu, Y. Luo, Z. Li, *A highly selective chemical gas sensor based on functionalization of multi-walled carbon nanotubes with poly(ethylene glycol)*, *Sens. Actuators B - Chem.* 126 (2007) 361-367.

-
- 13 G. Wei, H. Saitoh, F. Fujiki, T. Yamauchi, N. Tsubokawa, Grafting of branched polymers onto the surface of vapor grown carbon fiber and their electrical properties, *Polym. Bull.* 60 (2008) 219-228.
 - 14 M.C. Lonergan, E.J. Severin, B.J. Doleman, S.A. Beaber, R.H. Grubbs, N.S. Lewis, Array-based vapor sensing using chemically sensitive, carbon black-polymer resistors, *Chem. Mater.* 8 (1996) 2298-2312.
 - 15 J.E. Martin, R.A. Anderson, J. Odinek, D. Adolf, J. Williamson, Controlling percolation in field structured particle composites: Observations of giant thermoresistance, piezoresistance and chemiresistance, *Phys. Rev. B* 67 (2003) 094207.
 - 16 M.B. Heaney, Measurement and interpretation of nonuniversal critical exponents in disordered conductor-insulator composites, *Phys. Rev. B* 52 (1995) 12477-12480.
 - 17 B.C. Sisk, N.S. Lewis, Estimation of chemical and physical characteristics of analyte vapors through analysis of the response data of arrays of polymer-carbon black composite vapor detectors, *Sens. Actuators B- Chem* 96 (2003) 268-282.
 - 18 M. Belmaraes, M. Blanco, W.A. Goddard III, R.B. Ross, G. Caldwell, S-H. Chou, J. Pham, P.M. Olofson, C. Thomas, Hildebrand and Hansen solubility parameters from molecular dynamics with applications to electronic nose polymer sensors, *J. Comput. Chem.* 25 (2004) 1814-1826.
 - 19 B.C. Sisk, N.S. Lewis, Comparison of analytical methods and calibration methods for correction of detector response drift in arrays of carbon black-polymer composite vapor sensors, *Sens. Actuators B – Chem.* 104 (2005) 249-268.
 - 20 J.W. Gardner, J.A. Covington, S-L. Tan, T.C. Pearce, Towards an artificial olfactory mucosa for improve odour classification, *Proc. Roy. Soc. A* 463 (2007) 1713-1728.
 - 21 F.K. Che Harun, J.E. Taylor, J.A. Covington, J.W. Gardner, An electronic nose employing dual-channel odour separation columns with large chemosensor arrays for advanced odour discrimination, *Sens. Actuators B - Chem.* 141 (2009) 134-140.
 - 22 Peratech Ltd, UK Patent, PCT/GB98/00206 (WO 98/33193).
 - 23 Peratech Ltd, World Patent, WO 99/38173.

-
- 24 D. Bloor, K. Donnelly, P.J. Hands, P. Laughlin, D. Lussey, A metal-polymer composite with unusual properties, *J. Phys. D: Appl. Phys.* 38 (2005) 2851-2860.
 - 25 D. Bloor, A. Graham, E.J. Williams, P. Laughlin, D. Lussey, Metal-polymer composite with nanostructured filler particles and amplified physical properties, *Appl. Phys. Lett.* 88 (2006) 102103.
 - 26 J-P. Korb, C. Chachaty, Diffusion and nuclear relaxation of solvent in a crosslinked polymer, *Bull. Magn. Res.* 11 (1989) 230-237.
 - 27 G.H. Cross, Y.T. Ren, M.J. Swann, Refractometric discrimination of void-space filling and swelling during vapor-vapor sorption in polymer films, *Analyst* 125 (2000) 2173-2175.
 - 28 Q-Q. Liu, L. Wang, A-N. Xiao, H-J. Yu, Q-A. Tan, A hyper-cross-linked polystyrene with nano-pore structure, *Eur. Polym. Jour.* 44 (2008) 2516-2522.
 - 29 N. Krasteva, Y. Fogel, R.E. Bauer, K. Müllen, Y. Joseph, N. Matsuzawa, A. Yasuda, T. Vossmeier, Vapor sorption and electrical response of Au-nanoparticle/dendrimer composites, *Adv. Funct. Mater.* 17 (2007) 881-888.
 - 30 B.J. Doleman, M.C. Lonergan, E.J. Severin, T.P. Vaid, N.S. Lewis, Quantitative study of the resolving power of arrays of CB-polymer composites in various vapor-vapor-sensing tasks, *Anal. Chem.*, 70 (1998) 4177-4190.
 - 31 M.P. Eastman, R.C. Hughes, W.G. Yelton, A.J. Ricco, S.V. Patel, M.W. Jenkins, Application of the solubility parameter concept to the design of chemiresistor arrays, *J. Electrochem. Soc.* 146 (1999) 3907-3913.
 - 32 S.V. Patel, M.W. Jenkins, R.C. Hughes, W.G. Yelton, A.J. Ricco, Differentiation of chemical components in a binary solvent vapor-vapor mixture using carbon/polymer composite-based chemiresistors, *Anal. Chem.* 72 (2000) 1532-1542.
 - 33 B.A. Miller-Chou, J.L. Koenig, A review of polymer dissolution, *Prog. Polym. Sci.* 28 (2003) 1223-1270.
 - 34 A.F.M. Barton, *CRC Handbook of Solubility Parameters and Other Cohesion Parameters*, 2nd Ed., CRC Press, Boca Raton, 1991.
 - 35 M. Roth, Solubility parameter of poly(dimethyl siloxane) as a function of temperature and chain length, *J. Polym. Sci: Pt. B: Polym. Phys.* 28 (1990) 2715-2719.

-
- 36 L.A. Utracki, R. Simha, Statistical thermodynamics predictions of the solubility parameter, *Polym. Int.* 53 (2004) 279-286.
- 37 A. Carrillo, I.R. Martin-Dominguez, A. Marquez-Lucero, Modeling and experimental testing of the effect of solvent absorption on the electrical properties of styrene butadiene rubber/carbon black chemical sensors, *Sens. Actuators B - Chem.* 113 (2006) 477-486.
- 38 M. Knite, K. Ozols, G. Sakale, V. Teteris, Polyisoprene and high structure carbon nanoparticle composite for sensing organic solvent vapors, *Sens. Actuators B - Chem.* 126 (2007) 209-213.
- 39 T Gao, E.S. Tillman, N.S. Lewis, Detection and classification of volatile organic amines and carboxylic acids using arrays of carbon black-dendrimer composite vapor detectors, *Chem. Mater.* 17 (2005) 2904-2911.
- 40 S-L. Tan, J.A. Covington, J.W. Gardner, Velocity-optimised diffusion for ultra-fast polymer based resistive gas sensors, *IEE Proc.-Sci. Meas. Technol.* 153 (2006) 94-100.