



THE UNIVERSITY *of* EDINBURGH

Edinburgh Research Explorer

Optimal Power Flow as a tool for fault level constrained network capacity analysis

Citation for published version:

Vovos, P, Harrison, G, Wallace, R & Bialek, JW 2005, 'Optimal Power Flow as a tool for fault level constrained network capacity analysis', *IEEE Transactions on Power Systems*, vol. 20, no. 2, pp. 731 - 741. <https://doi.org/10.1109/TPWRS.2005.846070>

Digital Object Identifier (DOI):

[10.1109/TPWRS.2005.846070](https://doi.org/10.1109/TPWRS.2005.846070)

Link:

[Link to publication record in Edinburgh Research Explorer](#)

Document Version:

Peer reviewed version

Published In:

IEEE Transactions on Power Systems

Publisher Rights Statement:

© 2005 IEEE. Personal use of this material is permitted. Permission from IEEE must be obtained for all other uses, in any current or future media, including reprinting/republishing this material for advertising or promotional purposes, creating new collective works, for resale or redistribution to servers or lists, or reuse of any copyrighted component of this work in other works.

General rights

Copyright for the publications made accessible via the Edinburgh Research Explorer is retained by the author(s) and / or other copyright owners and it is a condition of accessing these publications that users recognise and abide by the legal requirements associated with these rights.

Take down policy

The University of Edinburgh has made every reasonable effort to ensure that Edinburgh Research Explorer content complies with UK legislation. If you believe that the public display of this file breaches copyright please contact openaccess@ed.ac.uk providing details, and we will remove access to the work immediately and investigate your claim.



Optimal Power Flow as a Tool for Fault Level Constrained Network Capacity Analysis

Panagis N. Vovos, Gareth. P. Harrison, *Member, IEEE*, A. Robin Wallace and Janusz W. Bialek

Abstract--The aim of this paper is to present a new method for the allocation of new generation capacity, which takes into account fault level constraints imposed by protection equipment such as switchgear. It simulates new generation capacities and connections to other networks using generators with quadratic cost functions. The coefficients of the cost functions express allocation preferences over connection points. The relation between capacity and subtransient reactance of generators is used during the estimation of fault currents. An iterative process allocates new capacity using Optimal Power Flow mechanisms and readjusts capacity to bring fault currents within the specifications of switchgear. The method was tested on a 12-bus LV meshed network with 3 connection points for new capacity and 1 connection to a HV network. It resulted in significantly higher new generation capacity than existing first-come-first-served policies.

Index Terms-- Fault currents, load flow analysis, optimization methods, power generation planning.

I. INTRODUCTION

ELECTRICITY networks are called to accommodate more and more generation capacity in order to supply the increasing demand. However, social, planning and environmental reasons hinder the expansion of the existing infrastructure, whereas lack of investment prohibits its reinforcement. Therefore, the efficient utilisation of the existing network is not only suggested for economy, but also imposed by need.

The first-come-first-served policy currently enforced by most Independent System Operators (ISOs) in issuing connection permits protects the system from crossing its operating limits, but has no theoretical ground in terms of efficiency of allocation. Inadvertently, it potentially limits the capability of the network to absorb new generation capacity.

As an alternative, several coordination strategies have been proposed for a more effective allocation of new capacity [1]-[3]. The method proposed here uses a well-documented tool in power engineering, Optimal Power Flow (OPF), to allocate, optimally, new capacity to predefined connection points. The techniques and results can be easily adapted by ISOs for new capacity planning mechanisms that direct new capacity to specific locations through financial incentives. Subsequently, the investment force implicitly allocates the new capacity in an efficient manner.

However, as the installation of new generation capacity brings the network closer to its operational limits, concerns over safe and reliable supplies are raised [4]. For example, the introduction of new generation raises fault levels which may require upgrading of switchgear. Currently, the significant cost of upgrading is transferred to developers of new generation. Therefore, better utilization of existing infrastructure improves the investment conditions for new generation. Here, an iterative capacity allocation algorithm is presented, which considers fault level constraints introduced by existing switchgear.

II. THEORY

A. Definitions

Capacity allocation is the problem of defining the capacity of new generation on predetermined connection points within the existing network.

Optimal capacity allocation is the capacity allocation that maximises an objective function, usually the total new capacity, with respect to network constraints.

Network constraints are constraints imposed by statutory regulations (e.g., bus voltage limits) and equipment specifications (e.g., thermal limits on transmission lines and transformers). Here, fault level constraints imposed by switchgear capabilities are added to network constraints.

B. Optimal Power Flow

OPF is the process of dispatching the electric power system variables in order to minimize an operation criterion, while attending load and feasibility. The mathematical formulation of the problem is briefly described below.

It is assumed that the following are known: active and reactive power generation capabilities and costs, sizes of fixed loads, transmission and distribution line capacities, specification of fixed transformers and other power system devices. The control variables c , which are regulated during optimization, are usually the ones at the disposal of system operators:

- a) generator active and reactive power output.
- b) tap ratios and/or phase shifts of transformers with tap changers and/or phase shifting capabilities.
- c) settings of switched shunt devices, e.g., capacitor banks.
- d) active power transferred from DC links.
- e) shedding of interruptible loads.

However, in order to completely define the state of the system, more variables have to be introduced. The state variables s are:

- a) voltage phase angles at every bus.
- b) voltage magnitudes at load buses.

Manuscript received 27th April 2004 and in revised form 20th June 2004. This work is funded by a University of Edinburgh PhD Scholarship awarded to Panagis Vovos.

The authors are with the School of Engineering and Electronics, University of Edinburgh, Edinburgh, EH9 3JL UK. (E-mail: P.Vovos@ed.ac.uk).

The equation linking variables c and s is the power system load flow equation:

$$EqCon(c, s) = 0 \quad (1)$$

It can be analysed for a number of equality constraints, one for each bus, expressing the power balance between the active/reactive power injected and withdrawn from the bus.

Inequality constraints describe the power system's operating limits:

$$IneqCon(c, s) < 0 \quad (2)$$

Such constraints include line thermal limits, active and reactive power generation capability bounds, range of tap changers or phase shifters and voltage limits at buses. Additional operational constraints may be easily added, using expressions of the c and s variables describing operating violations, if they are valued as critical for the system security.

The "objective function" defines the operating criterion of the power system. In most cases, it is the short-term cost of electricity production. The OPF optimization process aims to find the variables c and s that minimise the objective function, subject to the equality and inequality constraints. It is a nonlinear programming problem:

$$\min f(c, s) \quad (3)$$

subject to (1) and (2).

C. Optimal capacity allocation using OPF

In the previous section, we briefly described the formulation of OPF, which is traditionally used as an operating tool in power systems. In the following paragraphs, we present how OPF can be used to allocate, optimally, new generation capacity.

1) Modeling Sinks and Sources

New generation capacities are simulated as generators with quadratic cost functions with negative coefficients:

$$C_g(P_g) = a \cdot P_g^2 + b \cdot P_g + c \quad (4)$$

w.r.t. $a, b, c < 0$ and $P_g > 0$, where C_g is the operational cost of generator g at output level P_g .

These generators are connected to predetermined locations in the network, the "Capacity Expansion Locations" (CELs), with the output of generators simulating the allocated capacity at the CEL. Different sets of coefficients between cost functions declare preferences for the allocation of new capacity between CELs.

Energy transfers from/to external networks are also simulated as generators with quadratic cost functions. We will refer to them as Export/Import Points (E/IPs). The coefficients of the cost functions are negative for exports and positive for imports. The outputs of the generators are negative when they represent exports and positive when they represent imports.

$$C_T(P_T) = a \cdot P_T^2 + b \cdot |P_T| + c \quad (5)$$

w.r.t. $a, b, c < 0$ and $P_T < 0$ for exports or $a, b, c > 0$ and $P_T > 0$ for imports, where C_T is the operational cost of the generator at output level P_T simulating the E/IP.

Existing generation capacities are simulated as generators with constant active power output ($P_{g,installed}$) and given reactive power ($Q_{g,installed}$) injection capabilities:

$$\begin{aligned} P_{g,installed} &= const. \\ Q_{g,installed}^{\min} &< Q_{g,installed} < Q_{g,installed}^{\max} \end{aligned} \quad (6)$$

Loads are simulated as sinks of constant active (P_D) and reactive (Q_D) power:

$$L_D = P_D + jQ_D \quad (7)$$

2) System Constraints

The amount of active and reactive power injected into any system bus k must equal the amount withdrawn from it. The complex power balance on the buses is formulated:

$$\sum_t (P_{tk} + jQ_{tk}) + \sum_g (P_{gk} + jQ_{gk}) + \sum_d (P_{dk} + jQ_{dk}) = 0 \quad (8)$$

where t =all lines, g =all generators and d =all loads connected to bus k . P_{tk}, P_{gk}, P_{dk} and Q_{tk}, Q_{gk}, Q_{dk} are the active and reactive power injected into bus k . If the bus is also an E/IP, then the complex power transferred from/to bus k from the external grid must be added to (for import) or subtracted from (for exports) the above sum.

Proper operation of the power system equipment and quality of supply requires the maintenance of bus voltages close to their nominal values:

$$V_b^{\min} < V_b < V_b^{\max}, \text{ for all buses } b \quad (9)$$

where V_b^{\min} and V_b^{\max} are the lower and upper bounds of the bus voltage V_b around the rated value.

The installation of new generation capacity is limited by statutory regulations on quality of supply, environmental concerns, planning policies, technological limitations or system constraints imposed by stability, fault or other security analyses. Here, only restrictions resulting from statutory regulations and fault analysis are used:

$$LB_g < P_g < UB_g \quad (10)$$

where LB_g and UB_g are the lower and upper bounds respectively for the generation output P_g at CEL g .

In most distributed generation applications, synchronous generators perform Automatic Voltage Regulation in power factor control mode [5]. Thus, in order to simplify our analysis we assume that CELs have constant power factors:

$$\cos \phi_g = P_g / \sqrt{P_g^2 + Q_g^2} = const. \quad (11)$$

This assumption holds for most Distributed Generation (DG) installations that interface to the network through an inverter [6]. However, in more general cases, the production of reactive power is more flexibly controlled or additional reactive power sources are utilized (e.g., FACTS). Then, this restriction can be relaxed providing higher generation capacities.

The thermal capacity of a line sets a limit to the maximum apparent power (MVA) transfer:

$$S_t < S_t^{\max}, \text{ for all lines } t \quad (12)$$

where S_t is the apparent power and S_t^{\max} is the thermal limit of line t .

Each E/IP represents a physical connection to an external network. The capacity of the connection sets a limit to the maximum amount of power that can be transferred to and from the external network. Furthermore, in cases where the quantity of the exported or imported power has a significant impact on the operation of the external grid, more conserva-

tive bounds than the connection capacity must be applied to limit the voltage rise or drop at buses within the external network. These limits are expressed as:

$$|P_T| < |P_T^{\max}|, \text{ for all E/IPs } T \quad (13)$$

where $P_T > 0$ for imports and $P_T < 0$ for exports.

In addition, we must provide the maximum reactive power $Q_T^{\max} > 0$ the external network can feed into the system and the minimum $Q_T^{\min} < 0$ it can absorb:

$$Q_T^{\min} < Q_T < Q_T^{\max}, \text{ for all E/IPs } T. \quad (14)$$

3) OPF Objective Function

The OPF Objective Function f is the total cost of all simulated generators. It includes the negative cost of generation at CELs and exports at EPs, as well as the cost of imports at IPs. The cost of losses could also be taken into account, but is ignored at this stage of research to confine the model to explore fault level optimization.

$$f(P_g, P_T) = \sum_g C_g(P_g) + \sum_T C_T(P_T) \quad (15)$$

4) OPF Target Function

The OPF Target Function g is the minimum of the objective function f , subject to (8)-(14):

$$g(P_g, P_T) = \min f(P_g, P_T) \quad (16)$$

Thus, the OPF problem reflects the optimal allocation of new generation capacity at CELs and the setting of energy transfers at E/IPs, with respect to the power system constraints.

D. Relation between Generator Size and Fault Currents

Fault currents are determined by the pre-fault voltage at the fault location and the network impedances: transmission and distribution lines, transformer serial impedances, load equivalent impedances and generator reactances. Switchgear operates during the subtransient period of generators' response after a fault. In order to study this period we set generators' reactance equal to their subtransient values [7].

The subtransient reactance for large generators is about 15-20% on the generator reactance base, while smaller generators have less than 15% [8]. We can describe this relation of p.u. reactance $X_{p.u.}^g$ (on the generator reactance base) to the MVA capacity S^g of the generator, using a general function:

$$X_{p.u.}^g = f(S^g) \quad (17)$$

If we convert the p.u. subtransient reactance from the generator's MVA base S_b^g to the overall system MVA base S_b , then:

$$X_{p.u.} = X_{p.u.}^g \cdot S_b / S_b^g \Rightarrow X_{p.u.} = f(S^g) \cdot S_b / S_b^g \quad (18)$$

However, as S_b^g is the generator's MVA capacity S^g , $X_{p.u.}$ is a function of S^g :

$$X_{p.u.}(S^g) = f(S^g) \cdot S_b / S^g \quad (19)$$

Equation (19) gives a rough estimation of the expected subtransient reactance $X_{p.u.}$ for new generation capacity S^g . By regulating the amount of new capacity, the sub-transient reactance that would be introduced into the network during a fault

is determined. The lower the new generation capacity, the higher the subtransient reactance and the lower the fault current. The opposite is also true.

E. Fault Level Constrained OPF

In the following section a generation capacity allocation algorithm is presented, which takes into account the additional constraints imposed by the power system tolerance to fault levels. Besides the control and state variables in OPF, no additional variables are needed.

The approach has been termed Fault Level Constrained OPF (FLCOPF). The following flowchart (Fig. 1) demonstrates the general principles of the algorithm.

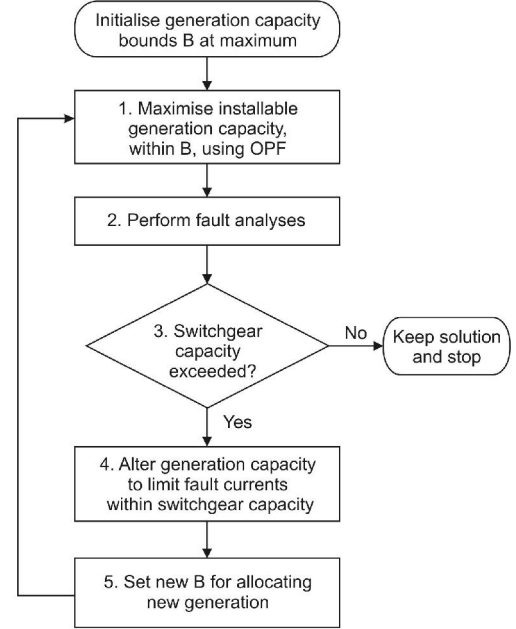

Fig. 1. Flowchart of Fault Level Constrained OPF algorithm.

It proceeds as follows:

1. The OPF is constrained by the bounds B for generation capacity. It a) allocates new capacities at CELs and sets import or output levels at E/IPs and b) calculates bus voltages.
2. Fault analyses are performed for a symmetrical three-phase fault at every bus, using a) generator subtransient reactances, determined from the size of the allocated capacities at CELs and b) pre-fault bus voltages resulting from the OPF.
3. The calculated fault currents determine which switchgear has inadequate capacity or breaking capability. If all switchgear is adequate, the current allocation of generation capacity is therefore optimal and the algorithm stops.
4. The Generator Reactance Optimisation Algorithm (GROA) finds the generator subtransient reactances that limit fault currents within the specifications of the inadequate switchgear identified in the previous step. The relation between generator capacity and subtransient reactance is used to convert reactances to capacities.
5. A comparison between the OPF capacity allocation and the readjusted capacities by GROA determines new bounds B. The control is passed back to the step 1, where OPF reallocates generation capacities using the new B. The basic opera-

tions performed within this algorithm are elaborated in the next paragraphs.

1) Maximization of generation capacity using OPF

A generator with a quadratic cost function is attached to each CEL and E/IP. Existing generation capacities are simulated as generators with constant active power output and given reactive power injection capabilities. The loads are simulated as sinks of constant active and reactive power.

OPF then allocates new capacity at CELs and sets energy transfers at E/IPs, by solving (16) subject to (8)-(14).

2) Fault analyses and evaluation of switchgear adequacy

In order to evaluate the adequacy and safety of switchgear under fault conditions, we must first estimate the expected fault currents. Switchgear connects or disconnects one end of a line to a system bus. Therefore, switchgear faces the same fault currents as the lines they are connected to.

Generally, the fault current $I_{i,j}^f$ in line i,j for a fault at bus f equals:

$$I_{i,j}^f = \left(V_i - V_j - (FSF_{i,f} - FSF_{j,f}) \cdot V_f \right) / \hat{z}_{i,j} \quad (20)$$

where Fault Sensitivity Factor

$$FSF_{k,m} = z_{k,m} / (z_{m,m} + z_f) \quad (21)$$

where $z_{d,g}$ are the elements at row d and column g of the system's bus impedance matrix $Z_{bus} (= Y_{bus}^{-1})$ and Z_f the fault impedance. V_b is the pre-fault voltage at bus b and $\hat{z}_{q,r}$ is the line impedance of line q,r .

Primarily, two specifications determine the adequacy of switchgear during faults: making and breaking capacity [9]. The analysis differentiates between the two at the point we have to consider the impact of the dc component on the calculated fault currents [10].

Specifically, we empirically determine the peak asymmetric current the switchgear must sustain right after the fault by multiplying the subtransient RMS current by a factor of 1.6 [11]. The result represents the minimum capacity that switchgear must possess.

The breaking capability of required switchgear is specified by the Short Circuit Capacity (SCC) of the bus it is connected to (MVA). The SCC is defined as the product of the absolute bus voltage before the fault and the absolute current during the fault:

$$|SCC| = \left| V_{bus}^{prefault} \right| \left| I_{switchgear}^{fault} \right| \quad (22)$$

The pre-fault bus voltage $V_{bus}^{prefault}$ is an output (s variable) of the OPF. $I_{switchgear}^{fault}$ is calculated using (20). In this case, we consider the dc component by increasing the calculated fault current values by a factor of 1.0 to 1.4, depending on the switching speed of the switchgear: the higher the speed the greater the factor [11]. If the calculated SCC is higher than the one described in the switchgear specifications, then the switchgear has inadequate breaking capability.

If the switchgear connects to a generation bus of more than 500 MVA, all the above factors are increased by 0.1 [11].

3) Limiting fault currents using Generator Reactance Optimization Algorithm

It is reasonable to assume that bus voltages do not change much between iterations, so fault currents in (20) are determined only by Z_{bus} . GROA readjusts the matrix by changing the size of new capacity in (19). The solution of a target function determines the optimal set of capacity sizes, keeping fault currents within switchgear specifications.

Two target functions have been tested for GROA. The first minimises the negative total cost, using the same cost functions C_i supplied to the OPF:

$$g_{GROA-I} (P_{1,GROA}, \dots, P_{n,GROA}) = \min \left\{ \sum_{i=1, \dots, n} C_i (P_{i,GROA}) \right\} \quad (23)$$

w.r.t constraints imposed by the specification of previously inadequate switchgear and $P_{i,GROA} < B_i^{old}$, where n is the number of CELs and B_i^{old} is the capacity bound of the current iteration for $CEL i=1, \dots, n$. $P_{i,GROA}$ is the MW capacity allocated from GROA to i :

$$P_{i,GROA} = \cos \phi_{i,GROA} \cdot S_{i,GROA} \quad (24)$$

where $\cos \phi_{i,GROA}$ and $S_{i,GROA}$ are the power factor and MVA capacity of the generator at i respectively. The second minimises the deviation from the OPF allocation:

$$g_{GROA-II} (S_{1,GROA}, \dots, S_{n,GROA}) = \min \left\{ \sum_{i=1, \dots, n} \left| S_{i,GROA} - \frac{P_i}{\cos \phi_i} \right| \right\} \quad (25)$$

w.r.t to the same constraints as (23).

The first generally leads to more efficient capacity allocation when preferences exist for the allocation of new capacity at specific CELs. The second speeds up the convergence of the overall algorithm and results in similar capacity allocation as the first when there are no preferences over CELs.

4) Changing the bounds of new capacities

Initially, the capacity bounds are determined by the maximum allowable generating capacity at CELs, due to technical, environmental or planning reasons. The OPF is solved and the new generation capacity is allocated. The subsequent fault analysis may prove that the current OPF allocation results in higher fault currents than would be safe for some switchgear. However, as we have already shown, the capacity size is directly connected to the generator subtransient reactance (hence, to fault currents, too) according to (19). GROA finds the optimal set of capacity sizes, which limit the fault currents within switchgear specifications.

The results of GROA ($S_{1,GROA}, \dots, S_{n,GROA}$) are compared with the OPF capacity allocation (S_1, \dots, S_n) at each CEL i . The upper capacity bounds in (10) change for the next loop as a function of their difference, from B_i^{old} to B_i^{new} . More precisely, the previous overall bounds change proportionally to the difference between the OPF results and the GROA bounds:

$$B_i^{new} = B_i^{old} - Step \cdot (S_i - S_{i,GROA}) \quad (26)$$

where B_i is the overall capacity bounds at CEL i and $Step$ is the proportional factor of $S_i - S_{i,GROA}$, equal to:

$$Step = (B_i^{old} - S_i) / B_i^{old} \quad (27)$$

Both system impedances and pre-fault bus voltages determine fault currents. When we change the capacity bounds to limit fault currents, we alter the way the power system is loaded and modify the bus voltage pattern. Therefore, abrupt changes of the capacity bounds would result in very different bus voltage patterns between iterations. Under such conditions, we cannot have a good estimation of the resulting fault currents when we change the generator reactance. The GROA leads the overall algorithm to convergence, because it reduces the capacity bounds in the direction of the optimal solution stepwise, thus enforcing small changes to the voltage patterns.

F. Algorithm implementation

The implementation of the algorithm is programmed in MATLAB. The Sequential Quadratic Programming (SQP) method is used to solve the OPF and run the GROA. A function is also programmed to perform a set of fault analyses; one analysis for a symmetrical 3-phase short circuit fault at each bus.

G. Example of capacity planning mechanism

ISOs can use the results of the above algorithm to exploit the potential connection capacity better. For example, the first-come-first-served policy can be replaced with a similar mechanism to the gradual release of capacity for transmission lines (see ‘Annual FTR Auction’ in [12]). Financial incentives could direct investment for new capacities to specific locations, so that all released capacity is distributed among investors by the end of each round.

The planning mechanism suggested here is just an oversimplified example of the way a planning mechanism could exploit the FLCOPF results. However, the similarities between transmission capacity release and connection capacity release are interesting: a) they both deal with a ‘scarce good’ in power systems (capacity) and b) buyers are interested in acquiring this good in different locations and time. Thus, the implementation of a mechanism based on transmission capacity release would share similar advantages.

III. EXAMPLE

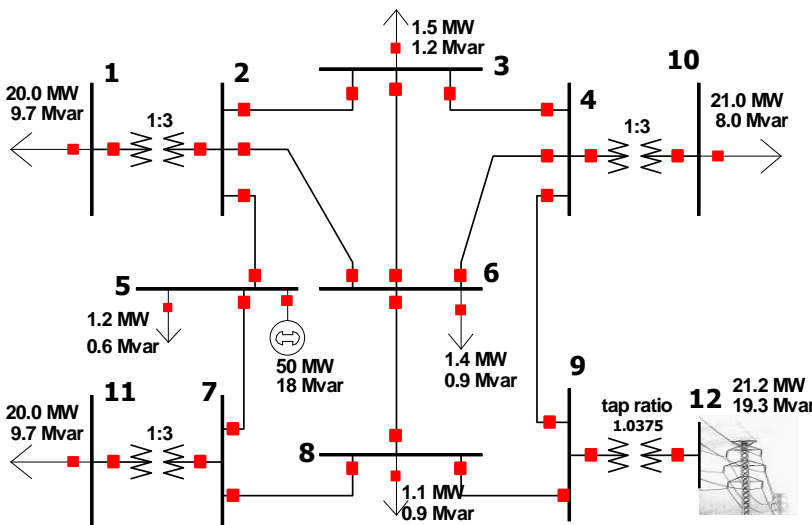

Fig. 2. The 12-bus 14-line test case and the table of transformer/line characteristics.

A. Topology

A 12-bus 14-line network (Fig. 2) has 3 available CELs at buses 1, 10 and 11. It also has an E/IP to an external network at bus 12. A 50 MW generator is installed on bus 5. It can consume or provide up to 34 MVar of reactive power. The network has a common rated bus voltage level at 33 kV, except for the CEL buses which have a rated voltage of 11 kV and the E/IP bus at 132 kV.

The CEL buses connect to the network through 30 MVA transformers with fixed taps. The E/IP bus connects through a 90 MVA transformer with automatic tap changer, which regulates the voltage within a $\pm 2\%$ range of the rated voltage at the low voltage side with a $\pm 10\%$ tap range around the nominal tap ratio. The electric characteristics of transformers and lines are presented in the table included in Fig. 2. Loads consume constant complex power on buses 1, 3, 5, 6, 8, 10 and 11. This network is termed ‘local’ and the hypothetical network connected through the E/IP as ‘external’.

Before the new capacity connects on the grid, the external network provides 21.2 MW and 19.3 MVar, while the generator at bus 5 operates at full capacity (50 MW, 17.6 MVar).

B. Constraints

Line 4-9 is constrained by a thermal limit of 40 MVA, while all other lines are considered to have unlimited capacity. We assume that the E/IP can exchange up to 100 MW with the external network without affecting its secure operation. The external network is also capable of providing up to 60 MVar of reactive power to the local network and consuming up to 50 MVar. To keep our example simple, we also assume that all new generators connected at CELs produce power at constant 0.9 lagging power factors and have an internal subtransient reactance of 15% on the generator reactance base. A hypothetical government policy also restricts the maximum allocated capacity to 200 MW at each CEL. Finally, statutory regulations limit bus voltage fluctuations to $\pm 10\%$ around the nominal values. Switchgear is tested only for capacity adequacy, assuming 250 MVA at 11 kV, 1000 MVA at 33 kV and 3500 MVA at 132 kV, which are typical UK ratings.

Line/Transf.	Buses	R (pu)	X (pu)	B (pu)	MVA
transformer	1-2	0	0.1667	0	30
line	2-3	0.48	0.3	0.0008	infinite
line	2-5	0.24	0.15	0.0004	infinite
line	2-6	0.72	0.45	0.001	infinite
line	3-4	0.64	0.4	0.001	infinite
line	3-6	0.64	0.4	0.001	infinite
line	4-6	0.48	0.3	0.0008	infinite
line	4-9	0.66	0.35	0.0009	40
transformer	4-10	0	0.1667	0	30
line	5-7	0.688	0.43	0.0006	infinite
line	6-8	0.768	0.48	0	infinite
line	7-8	0.56	0.35	0.0008	infinite
transformer	7-11	0	0.1667	0	30
line	8-9	0.768	0.48	0	infinite
transformer	9-12	0	0.0555	0	90

C. Current Capacity Allocation Policy

It is assumed that three investors request to connect the maximum possible capacity to the CELs at buses 10, 11 and 1 respectively. Their requests are processed on a first-come-first-served basis by the ISO.

This policy was simulated by sequentially relaxing the capacity bounds at the 3 CELs from 0 to 200 MW (as might be dictated by policy). At each turn, OPF was used to allocate the maximum possible capacity for the next CEL, simulating the allocated capacity of the previous CELs with “existing generators” operating at those capacities. The process was repeated using FLCOPF, in order to examine the effects of fault level constraints on generation capacity allocation. The results of the two allocations are demonstrated in Table I.

TABLE I
SEQUENTIAL CAPACITY ALLOCATION

CEL bus	OPF	FLCOPF
10	51.5 MVA	45.3 MVA
11	32 MVA	36.7 MVA
1	0 MVA	0 MVA
Total	83.5 MVA	82 MVA

OPF was restricted only by the statutory voltage limits at the CELs during the capacity allocation. On the other hand, FLCOPF allocated less generation capacity on bus 10, in order to reduce the fault level within the specifications of the isolating switchgear of the transformer between buses 4 and 10. As a result, the overall voltage levels were reduced and the potential connection capacity of bus 11 increased in the next round.

D. Coordinated Capacity Allocation

Two test cases were examined. In Case A, cost functions were applied to CELs that expressed no preference for the allocation of new capacity. In Case B, the cost functions express a preference for the allocation of new capacity at bus 1. Table II contains the cost function coefficients for each CEL and the E/IP for both cases, which specify (4) and (5).

TABLE II
COST FUNCTIONS USED IN TEST CASES

CEL bus	Case A			Case B		
	a	b	c	a	b	c
1	0	-20	0	0	-30	0
10	0	-20	0	0	-20	0
11	0	-20	0	0	-20	0
E/IP bus	a	b	c	a	b	c
12	0	-20	0	0	-20	0

In both cases, the initial OPF capacity allocation resulted in excess peak fault currents on the transformer connecting buses 4 and 10. The FLCOPF algorithm reallocated capacity at CELs in order to reduce fault currents within the switchgear specifications. Capacity from the bus 10 CEL was ‘shifted’ to the other CELs and a new optimum was reached, which respects both OPF and fault constraints. The highest flow exists in line 4-9 and is about 37 MVA for Case A, with an average of 20 MVA in all other lines. Such flows are under the thermal limits of 33kV lines of reasonable length. The solution is constrained from fault levels rather than line thermal limits, underlining the importance of the additional constraints in generation capacity allocation.

In both cases the algorithm converged in 13 iterations in less than 10 seconds (for a 1.7GHz AMD CPU). The final capacity allocation is presented in Table III, together with the initial OPF capacity allocation.

TABLE III
CAPACITY ALLOCATION AND TRANSFERS TO E/IP IN THE TWO CASES

CEL bus	Case A		Case B	
	OPF	FLCOPF	OPF	FLCOPF
1	12.3 MVA	13.6 MVA	34.9 MVA	35.9 MVA
10	52.3 MVA	49.1 MVA	52.0 MVA	48.8 MVA
11	38.2 MVA	38.4 MVA	11.6 MVA	12.2 MVA
Total	102.8 MVA	101.1 MVA	98.5 MVA	96.9 MVA
E/IP	-45.6 MW	-44.4 MW	-41.4 MW	-40.3 MW

The tap changer automatically sets the tap ratio of the 90 MVA transformer to 0.95 in Case A and 0.9625 in Case B to maintain the local network voltage level within statutory limits.

The reduction of total new capacity, from 101.1 MVA in Case A to 96.9 MVA in Case B, is connected to the impact that preferences have on the OPF target function (see (16)). In Case B, capacity on CEL at bus 1 has a higher negative cost (benefit) per MVA than other CELs and exports at E/IP. Therefore, capacity ‘shifts’ from other CELs to CEL at bus 1. In Table VI, the total benefits for the two test cases are calculated. Even though case B results in higher total benefit (value of g) the total capacity is less than in case A (see Table III).

TABLE VI
CALCULATION OF TOTAL BENEFITS FOR BOTH TEST CASES

CEL bus	Case A (Case B)		
	Allocated MW $P = \cos \phi \cdot S$	Benefit/ MW	Benefit
1	12.3 (32.3)	20 (30)	246 (969)
10	44.2 (44.0)	20 (20)	884 (880)
11	34.6 (11.0)	20 (20)	692 (220)
E/IP	44.4 (40.3)	20 (20)	888 (806)
TOTAL			2710 (2875)

Exports roughly reflect the excess capacity in the local network: the difference between total new capacity and demand. Indeed, both total new capacity and export of power in Case B is less than in Case A.

FLCOPF allocates 23% (Case A) to 18% (Case B) more new capacity, than the 82 MVA allocated under the current first-come-first-served ISO policy. ISOs can, however, use the above allocation to exploit the potential capacity better. For example, the first-come-first-serve policy could be replaced with a gradual release of connection certificates for all CELs in parallel (see Section II G). At each round, a certificate represents a fraction of the available capacity at a specific CEL. Financial incentives could direct investment for new capacities (e.g. subsidies) to specific locations, so that certificates for all CELs would be distributed among investors by the end of each round. Table V demonstrates such a release of certificates for Case A over four rounds.

TABLE V
RELEASE OF CAPACITY CERTIFICATES FOR CASE A

CEL bus	Round 1	Round 2	Round 3	Round 4
1	3.4 MVA	6.8 MVA	10.2 MVA	13.6 MVA
10	12.3 MVA	24.6 MVA	36.8 MVA	49.1 MVA
11	9.6 MVA	19.2 MVA	28.8 MVA	38.4 MVA

IV. DISCUSSION

As the power industry moves towards a more competitive environment, additional constraints become binding for power system operation [13]. Notably, fault levels and system stability are two constraints that should also be considered during OPF solution. Stability analysis involves the solution of many non-linear differential equations describing the dynamic oscillation of the machines in the power system. The solution of such equations requires numerical methods, thus, the incorporation of system stability as an additional constraint to OPF is not a straight forward process. Several suggestions have been published already in this field [14]-[15]. The authors acknowledge the importance of stability as a restricting factor for the installation of new generation, however they would like to stress that fault levels should also not be ignored. System stability constraints will be the target of a future research for us.

In our example we have assumed that all new generators are traditional synchronous machines, while new renewable power plants may often be inverter interfaced. However, we believe this assumption does not reduce the value of our example. The high speed current control and over-current shut-down inherent in inverter interfaced DG results in very low fault current contribution (less than 200% of the rated current) [6]. This could be taken into account in the ‘‘fault analyses’’ part of our algorithm by doubling the pre-fault rated current of those DGs and using this fault value during switchgear adequacy control, rather than using the one given from (19)-(20). Our example includes CELs accommodating only synchronous generators, because they have much higher fault current contribution, describing a ‘worst-case scenario’.

V. CONCLUSIONS

FLCOPF finds the optimal solution for the capacity allocation problem, subject to both network constraints and restrictions imposed by switchgear fault ratings. The algorithm allows locational preferences to be expressed for the connection of new capacity. It was proven that there is a trade-off between higher allocation of capacity at the preferred CELs and total new capacity. ISOs can use the resulting allocation in a capacity planning mechanism that exploits the potential connection capacity better than the current first-come-first-served policy.

VI. REFERENCES

- [1] G. P. Harrison and A. R. Wallace, ‘‘Maximizing Distributed Generation Capacity in Deregulated Markets,’’ *IEEE/PES Transmission & Distribution Conference & Exposition*, Dallas, USA, 7-12 Sept. 2003.
- [2] G. P. Harrison and A. R. Wallace, ‘‘OPF evaluation of distribution network headroom for the connection of distributed generation,’’ *Proc. Inst. Elect. Eng.-Gen. Transm. Dist.*, in review.
- [3] K. Nara, Y. Hayashi, K. Ikeda and T. Ashizawa, ‘‘Application of tabu search to optimal placement of distributed generators,’’ *IEEE Power Engineering Society Winter Meeting 2001*, pp. 918-923.
- [4] C. L. Masters, ‘‘Voltage rise: the big issue when connecting embedded generation to long 11kV overhead lines,’’ *Power Engineering Journal*, vol. 16, no. 1, pp. 5-12, Feb. 2002.
- [5] T. W. Eberly and R. C. Schaefer, ‘‘Voltage versus VAR/power-factor regulation on synchronous generators,’’ *IEEE Trans. Ind. Apps.*, vol. 38, pp. 1682-1687, 2002.
- [6] S. R. Wall, ‘‘Performance of inverter interfaced distributed generation,’’ *IEEE/PES Transmission & Distribution Conference & Exposition*, 2001.

- [7] M. G. Say, *Alternating Current Machines*, London: Pitman Publishing Ltd., 5th edition, 1983, p. 407.
- [8] J. M. Fogarty, ‘‘Connections between generator specifications and fundamental design principles,’’ *IEEE International Electric Machines and Drives Conference IEMDC 2001*, Cambridge, USA, pp. 51 - 56, 16-20 June 2001.
- [9] International Standard IEC 909, *Short-Circuit Calculation in Three-Phase AC Systems*, 1988.
- [10] J. J. Grainger and W. D. Stevenson, *Power System Analysis*, New York: McGraw-Hill, 1994, p. 403.
- [11] Preferred rating and related required capabilities for ac high-voltage circuit breakers rated on a symmetrical current basis, ANSI C37.06, 1987.
- [12] Pennsylvania, Maryland, Delaware, and New Jersey ISO, ‘‘Manual 6, Financial Transmission Rights’’, Section 6: FTR Auctions, pp. 31, 2004.
- [13] J. A. Momoh, R. J. Koessler, M. S. Bond, B. Stott, D. Sun, A. Papalexopoulos, and P. Ristanovic, ‘‘Challenges to optimal power flow,’’ *IEEE Trans. Power Sys.*, vol. 12, pp. 444-455, 1997.
- [14] D. Gan, R. J. Thomas, and R. D. Zimmerman, ‘‘Stability-constrained optimal power flow,’’ *IEEE Trans. Power Sys.*, vol. 15, pp. 535-540, 2000.
- [15] Y. Sun, Y. Xinlin, and H. F. Wang, ‘‘Approach for optimal power flow with transient stability constraints,’’ *Proc. Inst. Elect. Eng.-Gen. Transm. Dist.*, vol. 151, pp. 8-18, 2004.

VII. BIOGRAPHIES



Panagis N. Vovos was born in Athens, Greece, on October 23, 1978. He graduated from the Electrical Engineering Dept., University of Patras, Greece in 2002.

He is currently pursuing a PhD in the University of Edinburgh, from where he receives a scholarship. His special fields of interest include cross-border congestion management, efficient capacity allocation and enhanced OPF.



Gareth P. Harrison (M'02) is a Lecturer in Energy Systems in the School of Engineering and Electronics, University of Edinburgh. In addition to his work on integrating distributed generation into electricity networks, he is involved in analysing the impact of climate change on the electricity industry with emphasis on hydropower, marine energy and electricity demand.

Dr. Harrison is a member of the Institution of Electrical Engineers, UK and a Chartered Engineer.



Robin Wallace is Head of the Institute for Energy Systems at the University of Edinburgh. In addition to his research in network integration of distributed generation, he leads the Engineering and Physical Sciences Research Council's Supergen Marine Energy Consortium, and is a Consultant on small hydropower and distributed generation issues.

Dr. Wallace is a member of the Institution of Electrical Engineers, UK and a Chartered Engineer.



Professor Janusz Bialek obtained his MEng and PhD degrees from Warsaw University of Technology where he worked until 1989. From 1989 until 2001 he was with University of Durham, UK. Currently he holds the Chair of Electrical Engineering at the University of Edinburgh, UK. His main research interests are in the range of issues connected with liberalisation of electricity supply industry and in power system dynamics. He has authored 1 book and about 70 research papers.