



THE UNIVERSITY *of* EDINBURGH

Edinburgh Research Explorer

Network distributed generation capacity analysis using OPF with voltage step constraints

Citation for published version:

Dent, CJ, Ochoa, LF & Harrison, G 2010, 'Network distributed generation capacity analysis using OPF with voltage step constraints', *IEEE Transactions on Power Systems*, vol. 25/1, pp. 296-304.
<https://doi.org/10.1109/TPWRS.2009.2030424>

Digital Object Identifier (DOI):

[10.1109/TPWRS.2009.2030424](https://doi.org/10.1109/TPWRS.2009.2030424)

Link:

[Link to publication record in Edinburgh Research Explorer](#)

Document Version:

Peer reviewed version

Published In:

IEEE Transactions on Power Systems

Publisher Rights Statement:

© 2010 IEEE. Personal use of this material is permitted. Permission from IEEE must be obtained for all other uses, in any current or future media, including reprinting/republishing this material for advertising or promotional purposes, creating new collective works, for resale or redistribution to servers or lists, or reuse of any copyrighted component of this work in other works.

General rights

Copyright for the publications made accessible via the Edinburgh Research Explorer is retained by the author(s) and / or other copyright owners and it is a condition of accessing these publications that users recognise and abide by the legal requirements associated with these rights.

Take down policy

The University of Edinburgh has made every reasonable effort to ensure that Edinburgh Research Explorer content complies with UK legislation. If you believe that the public display of this file breaches copyright please contact openaccess@ed.ac.uk providing details, and we will remove access to the work immediately and investigate your claim.



Network distributed generation capacity analysis using OPF with voltage step constraints

C.J. Dent, *Member, IEEE*, L.F. Ochoa, *Member, IEEE*, and G.P. Harrison, *Member, IEEE*

Abstract—The capacity of distributed generation (DG) connected in distribution networks is increasing, largely as part of the drive to connect renewable energy sources. The voltage step change that occurs on the sudden disconnection of a distributed generator is one of the areas of concern for distribution network operators in determining whether DG can be connected, although there are differences in utility practice in applying limits. To explore how voltage step limits influence the amount of DG that can be connected within a distribution network, voltage step constraints have been incorporated within an established optimal power flow (OPF) based method for determining the capacity of the network to accommodate DG. The analysis shows that strict voltage step constraints have a more significant impact on ability of the network to accommodate DG than placing the same bound on voltage rise. Further, it demonstrates that progressively wider step change limits deliver a significant benefit in enabling greater amounts of DG to connect.

Index Terms—Optimization methods, Load flow analysis, Power generation planning.

I. INTRODUCTION

WORLDWIDE environmental concerns have placed restrictions on new large scale conventional power station developments. Additionally, concerns over security of fuel supply have led governments around the world to set targets to diversify their energy mixes in the forthcoming decades; indeed, incentives are already in place to encourage renewable and combined heat and power developments. It is expected that a number of these developments will be connected to the (traditionally passive) distribution network. Voltage control, fault levels, reliability and power losses are among the issues faced in integrating Distributed Generation (DG) which have been addressed in the literature [1]–[6]. Indeed, DG fundamentally changes the nature of distribution networks [7], [8], and therefore a number of studies have built DG planning models which consider the various technical requirements. In [9]–[11], the DG siting and sizing problem was solved using impact indexes, whereas analytical approaches were developed in [12], [13]. Mathematical optimisation approaches using metaheuristics [14]–[16] and a linear programming formulation [17], have also been applied. To take into account directly the intrinsic non-linearities of the problem, approaches based on AC optimal power flow (OPF) models have been proposed in [18]–[21].

This work is funded through the EPSRC Supergen V, UK Energy Infrastructure (AMPerES) grant in collaboration with UK electricity network operators working under Ofgem’s Innovation Funding Incentive scheme – full details on <http://www.supergen-amperes.org/>.

The authors are with the School of Engineering, The University of Edinburgh, Mayfield Road, Edinburgh EH9 3JL, UK (Email: chris.dent@ed.ac.uk, luis_ochoa@ieee.org, Gareth.Harrison@ed.ac.uk).

With higher penetration levels of DG, the benefits from appropriate siting of DG, whether driven by central planning or a system of financial incentives, are increasing. In order to maximise the potential of a network to accommodate DG, careful planning is required as connection of generation at some locations might significantly reduce the total capacity for DG [19], [22], and hence limit export to the transmission system. This is a particular concern where connection applications are dealt with on a first-come, first-served basis, without an analysis of the consequences for the network’s total capacity.

When assessing network capacity for connection of generation, it is necessary to consider all significant technical and physical constraints. Most DG studies have, however, overlooked a particular requirement of the distribution networks: voltage step constraints on loss of a generator, which is a quite distinct issue from voltage rise. Voltage step changes occur when a DG is started up or suddenly disconnected from the network, and limits are typically placed on the maximum step change allowed. In particular, in the UK, the Energy Networks Association’s Engineering Recommendation (ER) P28 [23] specifies a limit of 3% for infrequent planned switching events or outages, and 6% for unplanned outages (e.g. faults). There appears to be variation in UK practice regarding the allowable magnitude and frequency of voltage step changes (with some DNOs setting less stringent design limits in weak parts of their networks [24]). Work by the Energy Networks Association is ongoing to establish definitive practice. As a result, it remains crucial to take voltage step changes into account when evaluating the accommodation of new DG [25], [26].

While the process of starting a generator may lead to step changes in voltage levels, the sudden disconnection of a DG unit from the network due to faults or other causes will be the primary concern here. ER G75/1 [27] defines voltage step change:

Following system switching, a fault or a planned outage, the change from the initial voltage level to the resulting voltage level after all the Generating Unit automatic voltage regulator (AVR) and static var compensator (SVC) actions, and transient decay (typically 5 seconds after the fault clearance or system switching) have taken place, but before any other automatic or manual tap-changing and switching actions have commenced.

When using a power flow-based model to assess voltage step change, it can therefore be defined as the difference between the voltage level when the generation unit is connected, and the steady state voltage level with the same network topology

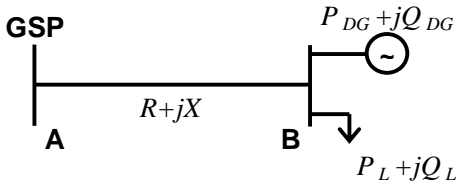

Fig. 1. Two bus system for voltage step analysis.

but with the generator disconnected. Clearly, evaluating the voltage step change caused by disconnection of a single DG unit is a straightforward procedure. Nonetheless, the complexity of the problem increases significantly when multiple generators are considered in a planning problem, since a single solution must satisfy the voltage step constraint on loss of each generator.

This paper proposes an optimal power flow (OPF) method for assessing the DG capacity of network which for the first time includes voltage step limits on loss of a generator, in addition to the usual OPF constraints (e.g. voltage level, thermal). This work builds on earlier studies on generation capacity assessment by mathematical optimisation [19]. Voltage step constraints are incorporated using a security constrained OPF-like formulation, where the contingencies considered are outages of generators rather than branches. While a 3% limit has been used for most of the examples in this paper, the methodology presented is generic, and would apply at any including the wider 6% UK limit for unplanned outages, and the 5% limit in common use in the USA [28].

This paper is structured as follows: Section II introduces the voltage step issue by way of a simple two-bus model. In Section III, the method for using an optimal power flow (OPF) model to determine network capacity for DG is described with the inclusion of voltage step constraints. Results from the method's application to a real part of the UK distribution network are presented and discussed in Sections IV and V. This demonstrates that a voltage step limit can actually be more restrictive of DG capacity than a voltage level limit with the same bounds. Finally, conclusions are drawn in Section VI. A full mathematical specification of the model is given in Appendix A.

II. VOLTAGE RISE AND VOLTAGE STEP

Voltage rise and voltage step are related but distinct phenomena. The differences between them may be illustrated using the two bus system shown in Fig. 1. This consists of a Grid Supply Point (GSP) at bus A, and load and generation at bus B.

Where power is exported from the DG towards bus A, the steady state voltage rise V_{BA} between buses A and B is given approximately by

$$V_{BA} = (P_{DG} - P_L)R + (Q_{DG} - Q_L)X, \quad (1)$$

where P_{DG} and Q_{DG} are the real and reactive outputs of the generator. Subtracting the voltage rise with the DG disconnected from the voltage rise with the DG connected, the voltage step V_S at bus B on loss of the generator (assuming

that the voltage at A remains constant) is

$$V_S = -(P_{DG}R + Q_{DG}X). \quad (2)$$

Unlike voltage rise, the step depends on the full output of the generator, and is not mitigated by load at the bus, or by transformer tap settings. *As a consequence, for a given limit on percentage deviation, the voltage step limit is expected to restrict DG capacity more than the commonly considered voltage level limits.*

If the generator is operated at lagging power factor, the reactive flow tends to reinforce the voltage step (and rise) due to the the generator active power output. At leading power factor the reactive flow tends to reduce the voltage step; conceivably, should the generator consume enough reactive power the voltage step may be upward.

The robustness of this simple two-bus model for assessing quantitatively voltage step changes will be explored in Section V. Nevertheless, it will be useful in interpreting qualitatively the results presented later.

III. DG CAPACITY ANALYSIS USING OPF MODELS

A. Previous Work

A range of optimisation tools have been applied to problems in optimal DG siting. In network generation capacity assessment (or, alternatively, capacity allocation) these range from the use of a full AC optimal power flow (OPF) model [19], and linear programming models including approximate implementations of fault, voltage and thermal constraints [22], to the use of genetic algorithms [29] (which also considered investment and operational costs, and losses, in a multi-objective problem). Other approaches to DG optimisation problems at distribution level have included tabu search for loss minimisation [30] and a genetic algorithm to decide the optimal investment schedule over a number of years [15] (this allows the consideration of investment deferral benefits from DG.)

The OPF for DG capacity analysis is based on the concept that the network's capacity for new generation may be found by placing DG expansion sites at the appropriate buses, and using an OPF model to evaluate the maximum total generation which the network can support at these sites [19]. It requires only slight modifications to the OPF model used for classical applications such as cost minimisation, which already includes Kirchhoff's laws, thermal and voltage constraints. The capacity at each site is a decision variable in the problem, as opposed to a fixed parameter. As is common with DG [31], the generators are assumed to be run in constant power factor mode (i.e. with no voltage control), although alternative operational modes are possible [32]. This method has already been extended to include fault level constraints [33] and evaluating the maximum capacity with a fixed number of DG sites [34].

The objective function is simply the total DG active power capacity in the network, i.e. the sum over the individual capacities p_n of the new generators n :

$$\max \sum_{n \in N} p_n. \quad (3)$$

The simplest version of the OPF method may be implemented in some commercial power systems modelling packages [19]. However, more advanced features such as voltage step and fault level constraints necessitate a bespoke OPF formulation. A full model specification is given in Appendix A.

B. Voltage Step Constraints

With voltage step defined on the basis of conditions pre- and post-disconnection of the DG, it can be viewed as being analogous to a line outage contingency. Line outage security constraints have been included in OPF models for many years; these models are typically referred to as Security Constrained OPFs (SCOPF, see [35] for a review of methods and applications). The generic formulation is to include as constraints in the OPF a set of power flow equations in the revised network topology for each outage considered. This ensures that immediately post-contingency all load can still be supplied with no voltage and thermal limit violations. For the full nonlinear AC OPF required for distribution networks, the entire power flow must be inserted into the model to implement limits even on just one line.

Voltage step constraints can be implemented similarly to the SCOPF where each contingency is an outage of a new DG site, and is therefore labelled by an index n' . For each contingency network a set of power flow equations is added as constraints to the OPF model. The contingency power flow equations are identical to the base case ones with the exceptions that the power injected from the outage generator is zero, and that contingency voltage variables, line flows, etc. are used in the constraints where appropriate.

The voltage step constraint itself takes the form

$$V_b - V_S^+ \leq V_{n',b} \leq V_b + V_S^+ \quad \forall n' \in N, \quad (4)$$

where for an outage of generator n' , the contingency voltage $V_{n',b}$ at bus b must differ from by no more than V_S^+ from the pre-outage voltage V_b .

C. Voltage Regulation

Transformer tap settings are used in distribution networks to keep the secondary bus voltages as close to target voltage (typically nominal) as possible. Although real tap changers operate in discrete steps, in the OPF the tap ratios are treated as continuous decision variables (modelling discrete settings would result in a much harder mixed integer nonlinear optimisation problem.) Following the practice in [19], all transformer secondary buses are constrained to exactly nominal voltage in the intact network. The existence of parallel transformers between the same bus or multiple paths through the network means that highly unbalanced power flows on transformer pairs are possible. In order to avoid this, multiple transformers connected in parallel to the same bus are constrained such that their tap settings are equal. This mirrors actual transformer practice, although it is also possible to limit the difference in tap settings where multiple paths are not exactly equivalent. To meet the definition of voltage step change (Section I), the tap settings applied in the post-outage contingency power flows are identical to those in the pre-outage flows (i.e. the voltage

step is defined before the transformers have time to react to the loss of infeed).

D. Redundancy Constraints

Distribution networks are designed with built-in redundancy in order to ensure continuity of supply during outages [36]. Typically the multiple supply paths to the load would take the form of parallel transformers at substations, and double circuits or reconfigurable connections to neighbouring sections of the network. Where DG is expected to export significant amounts of power through parallel sets of transformers and circuits, the worst-case firm connection assessment would assume that one of the circuits is out-of-service. This will typically reduce the connectable capacity at that site, and as a result may influence capacity elsewhere. To ensure that the flow may be carried by one component alone during an outage, an approximate approach is to constrain the total flow in parallel pairs of components to the smaller of the components' thermal limits. While it does not treat exactly parallel network sections whose layouts are not exactly symmetrical, it barely increases the size of the mathematical optimisation problem. Further work is planned on this.

E. Implementation

The OPF is implemented in the AIMMS optimisation modelling environment [37], a high level language in which the model structure is defined in a manner almost identical to its paper formulation (given in Appendix A). In common with other optimisation modelling languages [38], the mathematical program is generated by AIMMS from the model structure and data with the first and second derivatives of the constraints evaluated automatically for non-linear models. The mathematical program is sent to the CONOPT general reduced gradient solver [37], which has proved absolutely reliable in convergence on a class of much larger security-constrained OPF problems [39], and is reasonably efficient.

IV. CASE STUDY

A. Test Network

The capacity evaluation method is demonstrated on the small section of the UK distribution network shown in Fig. 2, a subsection of the network presented in the original paper to use OPF for DG capacity evaluation [19]. The mainly rural network has significant potential for wind and other renewable developments, and is representative of many UK networks. Key network parameters are listed in Appendix B.

For the initial analysis, voltage step constraints are ignored and potential DG is allowed to connect at buses 21, 23 and 26. The secondary buses of transformers are regulated to nominal voltage, with tap ratios constrained between 0.9 and 1.1, and the tap settings of parallel transformers allowed to vary independently. In the base case, steady-state bus voltages at 11 and 33 kV are constrained within $\pm 3\%$ of nominal to satisfy the more onerous planning requirements of Engineering Recommendation P28 [23], rather than the $\pm 6\%$ allowable by statute [40]. The GSP at bus 6 is at nominal voltage.

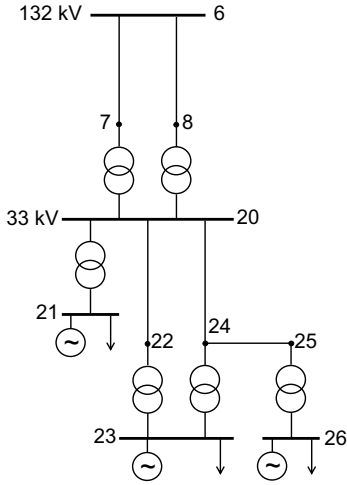

Fig. 2. Section of UK distribution network. Buses 21, 23 and 26 are at 11 kV.

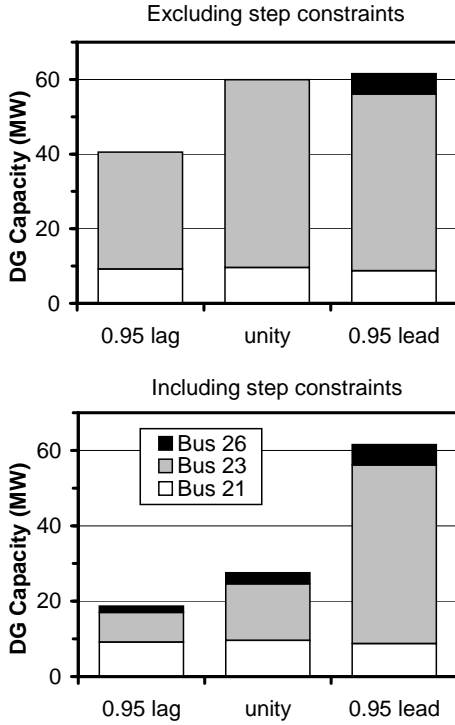

Fig. 3. DG capacity without (top) and with (bottom) voltage step constraints applied for three DG power factors.

The maximum DG capacity (MW) available in the network is shown in Fig. 3 (top) for DG power factors fixed at 0.95 lagging, unity and 0.95 leading. The results are consistent with those presented using the same network in [19]. The active inequality constraints, i.e., those restricting DG capacity, are listed in Table I where $V^{(+,-)}(b)$ denotes the (upper,lower) voltage limit at bus b and $f^+(l,t)$ the thermal limit on a line or transformer.

The capacity available at leading DG power factor exceeds that at lagging power factor by around 21 MW. Operation at lagging power factor results in a tendency for active and reactive power flows to be in the same direction, jointly contributing to voltage rise. In this case upper voltage limits

TABLE I
ACTIVE CONSTRAINTS WITHOUT VOLTAGE STEP CONSTRAINTS

Power factor	Active constraints
0.95 lagging	$V^+(b_{22}), V^+(b_{24}), f^+(t_{20-21})$
unity	$V^+(b_{25}), f^+(l_{20-22}), f^+(t_{20-21})$
0.95 leading	$f^+(l_{20-22}), f^+(t_{20-21}), f^+(t_{25-26})$

TABLE II
ACTIVE CONSTRAINTS WITH VOLTAGE STEP CONSTRAINTS ENFORCED

Power factor	Active constraints
0.95 lagging	$f^+(t_{20-21}), V_S^-(b_{23}, g_{23}), V_S^-(b_{26}, g_{26})$
unity	$f^+(t_{20-21}), V_S^-(b_{23}, g_{23}), V_S^-(b_{25}, g_{26})$
0.95 leading	$f^+(l_{20-22}), f^+(t_{20-21}), f^+(t_{25-26})$

on the 33 kV feeders (at buses 22 and 24) constrains capacity at buses 23 and 26 to 31 MW and zero MW respectively. At leading power factor, active and reactive flows are in opposite directions, reducing voltage rise, with thermal limits becoming binding. As the circuits from bus 6 to 20 have high capacity and relatively low reactance, the generation at bus 21 is always restricted to around 9 MW by the thermal limit of the transformer connecting it to bus 20.

B. Applying Voltage Step Constraints

If a limit of $\pm 3\%$ is placed on the voltage step at each bus on loss of a generator, the DG capacity able to be connected changes as shown in Fig. 3 (bottom), as do the active constraints (Table II). In addition to the symbols defined earlier, $V_S^+(b,g)$ and $V_S^-(b,g)$, respectively denote the upper and lower voltage step constraint at bus b when generator g disconnects. Upwards voltage steps are taken as positive and vice versa.

At leading power factor, the result is identical to that without step constraints as, once more, active and reactive power contributions to the voltage step partly cancel and the thermal constraints become active before the voltage step limits.

The voltage step constraints significantly reduce the total generation capacity at lagging and unity power factors (by 22 and 32 MW respectively). Capacity at buses 23 and 26 is constrained by the allowed voltage step at those buses or the primary bus of the associated transformer, when the voltage steps are not mitigated by the DG reactive power export. The ‘primary bus’ constraint is active at unity power factor, on disconnection of the DG at bus 26; the voltage step of -3% at bus 25 is then slightly greater than that of -2.94% at bus 26. This unexpected result occurs because the transformer connecting 25 and 26 is modelled as having reactance only. With no reactive power flow from the DG the transformer impedance effectively makes no contribution to the voltage step. Capacity at bus 21 remains the same on imposition of voltage step constraints; it is still restricted by the thermal constraint on its associated transformer.

It is notable that here the voltage rises at generators are smaller than the voltage steps on loss of the generators. As stated in Section II, this will usually be the case as voltage rise is for a given network state determined by the actual

TABLE III
OPTIMAL REAL POWER CAPACITIES AND POWER ANGLES.

Generator	Capacity (MW)	Power factor
Bus 21	9.62	0.980 lagging
Bus 23	49.83	0.978 leading
Bus 26	5.49	0.955 leading
Total	64.94	

power flows (i.e. generation minus load) whereas voltage steps are determined by the generator output without subtraction of demand. In addition, voltage rise may be reduced using transformer settings, whereas this has a much smaller influence over the step changes.

C. Variable Power Factor

It is clear that the DG power factor plays a major role in determining maximum capacity. As a result, where flexibility of power factor is allowed, capacity can be increased [32]. To investigate this further, the DG power factors (strictly the power angles) were treated as independent decision variables in the OPF. Re-running the assessment with power factor allowed to vary between 0.95 leading and lagging, the optimal DG parameters are as shown in Table III; the total capacity increases by 3MW over the 0.95 leading power factor case.

With the increase in control variables, the number of active constraints restricting the optimal solution increased from three to six: voltage step at $V_S^+(g_{23}, b_{22})$ and $V_S^+(g_{26}, b_{25})$; thermal constraints $f^+(l_{20-22})$, $f^+(t_{20-21})$ and $f^+(t_{25-26})$; and the lower tap limit on the bus 7 to 20 transformer. Independently of the other generators, DG capacity at bus 21 is always limited by the transformer thermal constraint with the power factor chosen to maximise the real power export. At the other two buses, the optimal power factor is usually determined by the voltage step and rise limits.

Results obtained with synchronised tap settings for parallel transformers have been compared with those where tap settings are allowed to vary independently. For the variable power factor case, the capacity under independent operation is negligible, but the reactive flows between buses 6 and 20 become highly unbalanced (the synchronised case showed approximately equal reactive flows.)

When redundancy constraints are added (so that where parallel branches exist one branch alone can support the entire power flow in case of an outage, see Section III-D) the network capacity reduces by 10.7 MW. The change occurs on bus 23 alone; the circuits connected to bus 20 have sufficiently high limits that the redundancy constraints do not affect the other generator sites.

D. Dependence of Capacity on Voltage Step Limit

The variation of optimal DG capacity with allowable voltage steps of up to 6% is shown in Fig. 4 for the fixed and variable power factor cases. Fig. 5 shows the classes of active constraints which limit the capacity in the variable power factor case. At fixed power factors of 0.95 lagging and unity there is an approximately linear relationship between connectible

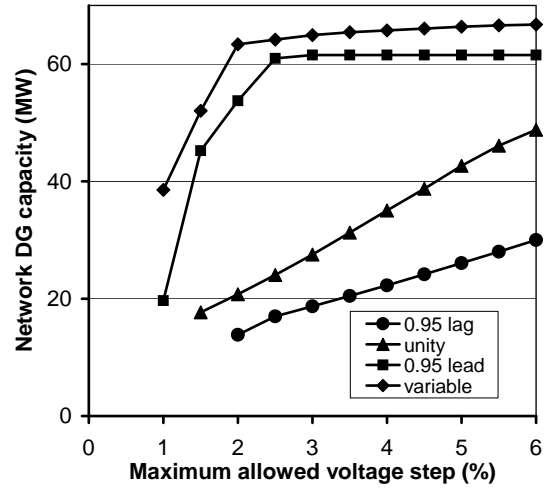

Fig. 4. Variation of the optimal DG capacity with maximum allowed voltage step, both a range of fixed power factors and for variable power factors.

capacity and allowable voltage step with the maximum voltage step acting as a significant constraint on capacity. At 0.95 leading power factor the capacity is very sensitive to voltage step limit, although when the limit exceeds 3% its effect is mitigated sufficiently that other constraints become active.

Operation with variable power factor again allows greater capacity to connect across all voltage step limits, and is slightly less sensitive to voltage step limits than leading power factor operation. As might be expected, at small voltage step tolerances, these constraints dominate, although this could be alleviated to some extent by allowing a wider range of power factors. The first qualitative change occurs when the step limit reaches 2%, at which point the only two active step constraints are those at the primary buses of the transformers connected to buses 23 and 26, on loss of the generators at those buses.

As the step constraint is relaxed further, the upper voltage limit at bus 25 becomes active in place of the step constraint on loss of the generator at 26. Finally, with the step limit above 5%, the allowed range of power angles does not allow sufficient reactive power generation to maintain the voltage limit at 25 with the associated transformer at its thermal limit, and some generation capacity transfers from bus 26 to bus 23.

When a thermal limit in one of the parallel branches is active, the relevant redundancy constraint reduces the effective degrees of freedom of the system by one; this is why for voltage step limits above 2% there are only five active constraints.

V. DISCUSSION

This paper demonstrates a novel and effective means of incorporating voltage step change constraints within assessment of distribution network capacity for connecting new DG. This is believed to be the first work to demonstrate the importance of voltage step change in the context of DG connection and planning. The step constraints are included within the OPF in a manner that mirrors that of the well known security constrained OPF by including contingency power flow equations in the optimisation model. The enforcement of relatively

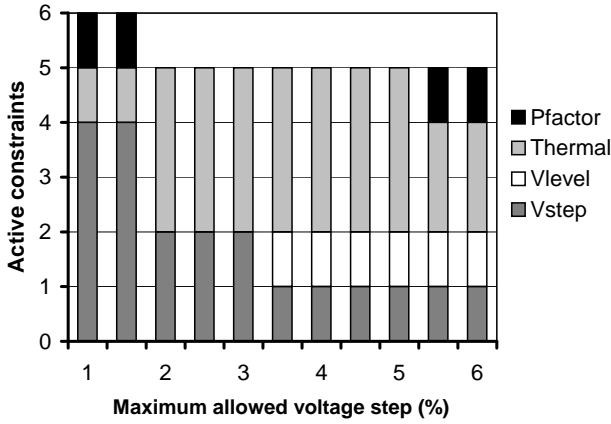

Fig. 5. Active constraint types for a range of maximum allowed voltage steps, with variable power factors.

strict voltage step constraints has a significant negative impact on the amount of DG capacity that may be accommodated, more so than an equivalent limit on voltage rise. Voltage step constraints are most significant at lagging power factors when the active and reactive power flow contributions reinforce each other. It has been shown that operation at leading power factor alleviates both voltage and voltage step constraints allowing greater volumes of DG to connect. However, as progressively wider step change limits are allowed, more network capacity becomes available.

The exact voltage step model, which includes generator outage contingency power flow constraints in the OPF adds significantly to the computational overhead (including n_c contingency flows multiplies the size of the OPF model by approximately $n_c + 1$.) The possibility of using the simpler two bus model from Section II as an approximate method of enforcing voltage step constraints has been examined as a means of reducing the computational burden.

The approximate expression for the voltage step given in (2) was evaluated using as inputs the impedances of the network from buses 21, 25 and 26 to the grid supply point at bus 6, and the fixed power factor active and reactive power injections for the optimal DG capacities in Fig. 3. The approximation was found to be fairly good at lagging and unity power factor. However, as Fig. 6 shows, its performance at leading power factor is poor with, for example, the sign of the voltage step on loss of generator 23 incorrectly predicted. This is because the active and reactive power flows have opposite signs but similar magnitudes, which magnifies the relative error. As leading power factors are likely to provide the optimal capacity where step constraints are significant, the full contingency approach demonstrated here will therefore be necessary.

This paper has been primarily motivated by the assessment of network generation capacity, with one additional application being to consider whether a proposed DG project will adversely affect the capacity of the network to host DG elsewhere. The Lagrange multipliers of the various constraints could guide planning decisions, by giving guidance as to where the greatest benefit can be obtained from the relaxation of voltage and thermal constraints [41]. It must be remembered

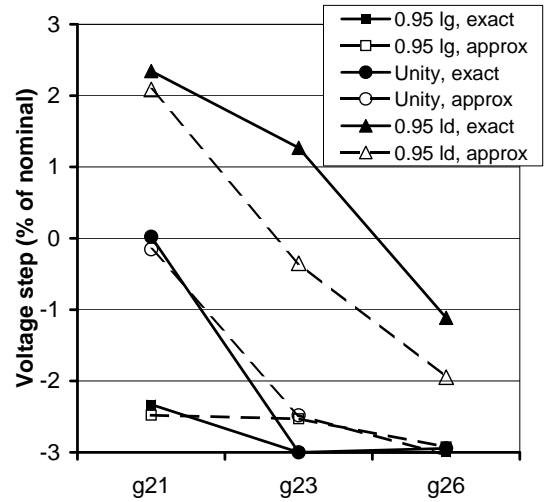

Fig. 6. Comparison of the exact voltage steps at the generator buses with the two bus approximation from Section II. Solid lines denote the exact approach, and dotted lines the approximate approach. In each case the optimal generator capacities with a voltage step limit of 3% are used.

however that Lagrange multipliers only give the effect of marginal constraint relaxations; as a constraint is relaxed further, another may become active and prevent further benefit.

Beyond this particular application, this paper provides an example of the flexibility of the OPF approach to network generation capacity assessment. Within an appropriate optimisation modelling environment, a variety of additional technical constraints may be implemented in a fairly straightforward manner, by including contingency power flow constraints in an security-constrained OPF-like manner.

VI. CONCLUSIONS

The voltage step change that occurs on the sudden disconnection of a distributed generator an area of concern for distribution network operators. To explore how voltage step limits influence the amount of DG that can be connected within a distribution network, voltage step constraints have been incorporated in a novel way within an established OPF-based method for determining the capacity of the network to accommodate DG.

The assessment shows that enforcement of relatively strict voltage step constraints has a significant impact on the amount of DG capacity that may be accommodated, more so than an equivalent limit on voltage rise. Voltage step constraints have the greatest impact at lagging DG power factors when the active and reactive power flow contributions reinforce each other, while operation at leading power factor tends to alleviate both voltage and voltage step constraints. It has been demonstrated that where progressively wider step change limits are allowed, there is significant benefit in enabling greater amounts of DG to connect.

APPENDIX A FULL OPF FORMULATION

A. Base Case OPF

All new generators $n \in N$ are assumed to be available.

1) *Objective function - maximise new DG capacity (MW):*

$$\max \sum_{n \in N} p_n, \quad (5)$$

where p_n is the real power capacity of new generator n , and N is the set of all new generators.

2) *Capacity constraint for DG (MW):*

$$p_n^- \leq p_n \leq p_n^+ \quad \forall n \in N \quad (6)$$

p_n^\pm are the upper and lower limits on the capacity of new generator n .

3) *Grid Supply Point:* Within this test example, there is a single GSP of unlimited capacity; hence, the grid supply variables p_x^X and q_x^X are unrestricted in range. The GSP will be the slack bus in the power flow models, and hence its voltage phase is to be zero:

$$\delta_{\beta_{\text{GSP}}} = 0, \quad (7)$$

where the location of the GSP is β_{GSP} .

4) *Bus voltage level constraint:*

$$V_b^- \leq V_b \leq V_b^+ \quad \forall b \in B \quad (8)$$

V_b is the voltage level at bus b for the base-case power flow (i.e. all generators connected). V_b^\pm are the upper and lower voltage limits at bus b , and B is the set of buses.

5) *Kirchhoff voltage law (KVL) - lines:* At two terminal buses for line l (denoted β_l^1 and β_l^2) the active and reactive power injections onto the line are given in terms of voltage levels and phases by the standard KVL formula. At bus 1, the active ($f_l^{1,P}$) and reactive ($f_l^{1,Q}$) injections are given by:

$$\begin{aligned} f_l^{1,P} &= g_l V(\beta_l^1)^2 - \\ &V(\beta_l^1)V(\beta_l^2) [g_l \cos(\delta(\beta_l^1) - \delta(\beta_l^2)) \\ &+ b_l \sin(\delta(\beta_l^1) - \delta(\beta_l^2))] \end{aligned} \quad (9)$$

$$\begin{aligned} f_l^{1,Q} &= -b_l V(\beta_l^1)^2 - \\ &V(\beta_l^1)V(\beta_l^2) [g_l \sin(\delta(\beta_l^1) - \delta(\beta_l^2)) \\ &- b_l \cos(\delta(\beta_l^1) - \delta(\beta_l^2))] \end{aligned} \quad (10)$$

$f_l^{(1,2),(P,Q)}$ are the real (P) and reactive (Q) power injections onto the two connection buses (1,2) of l . g_l and b_l are respectively the conductance and susceptance of line l . The active and reactive equations for injection at bus β_l^2 may be obtained by transposing the labels 1 and 2 in (9) and (10). These constraints must be applied for all lines l in L , the set of all lines.

6) *Kirchhoff voltage law - transformers:* These are identical in form to the KVL constraints for lines, except that the primary voltage must be divided by the transformer tap ratio τ_t . For instance, the KVL expression for real power injection at the primary:

$$\begin{aligned} f_t^{1,P} &= \left| \frac{V_{\beta_1}}{\tau} \right|^2 g_t \\ &- \left| \frac{V_{\beta_1}}{\tau} \right| |V_{\beta_2}| [g_t \cos(\delta_{\beta_1} - \delta_{\beta_2}) + b_t \sin(\delta_{\beta_1} - \delta_{\beta_2})] \end{aligned} \quad (11)$$

The primary and secondary buses are denoted 1 and 2 respectively, and the injections defined as for the lines. These

constraints must be applied for all transformers t in T , the set of all transformers.

7) *Tap ratio limit:*

$$\tau_t^- \leq \tau_t \leq \tau_t^+ \quad \forall t \in T \quad (12)$$

where τ_t^\pm are the upper and lower limits on the tap ratio of transformer t .

8) *Kirchhoff current law:* The sum of the grid supply and generation at bus b is equal to the total power injected onto lines and transformers plus the nodal demand at b . $\forall b \in B$,

$$\sum_{x \in X_b} p_x^X + \sum_{n \in N_b} p_n = \sum_{l \in L} p_b^{\text{LT}} + d_b^P \quad (13)$$

$$\sum_{x \in X_b} q_x^X + \sum_{n \in N_b} (\tan \phi_n) p_n = \sum_{l \in L} q_b^{\text{LT}} + d_b^Q \quad (14)$$

The terms $(p, q)_b^{\text{LT}}$ are the sum of all power injections onto lines and transformers at b . The reactive power line injection term includes the capacitance term

$$-\frac{(V_b)^2}{2} \left[\sum_{l \in L | \beta_l^1 = b} b_l^C + \sum_{l \in L | \beta_l^2 = b} b_l^C \right],$$

where b_l^C is the shunt capacitance of the line.

9) *Flow limit constraints:* Constraints on power injections at each end of lines, and the primary and secondary buses of transformers:

$$(f_l^{(1,2),P})^2 + (f_l^{(1,2),Q})^2 \leq (f_l^+)^2 \quad \forall l \in L \quad (15)$$

$$(f_t^{(P,S),P})^2 + (f_t^{(P,S),Q})^2 \leq (f_t^+)^2 \quad \forall t \in T \quad (16)$$

B. Voltage Regulation Constraints

T_b is defined as the set of transformers whose secondary bus is b , and which therefore regulate bus b .

1) *Voltage regulation constraint:* For the results presented here, the voltage of regulated buses is 1 p.u. in the base case power flow. This is formulated in the AIMMS optimisation environment as:

$$V_b = 1 \quad \forall \{b \in B | T_b \neq \emptyset\} \quad (17)$$

(the regulated buses are those where T_b is not empty.)

2) *Parallel transformer constraint:* A simple model for synchronised operation of transformers which regulate the same bus is to constrain their tap ratios to be equal:

$$\tau_{t_1} = \tau_{t_2} \quad \forall b \in B, (t_1 \neq t_2) \in T_b \quad (18)$$

Alternatively, enforcing a maximum difference between the tap ratios would be almost as straightforward.

C. Transformer Outage Constraints

The total power flow across a pair of parallel transformers is constrained below the thermal limits of each. $\forall (b \in B, t \in T_b)$,

$$\left(\sum_{t' \in T_b} f_{t'}^{1,P} \right)^2 + \left(\sum_{t' \in T_b} f_{t'}^{1,Q} \right)^2 \leq (f_t^+)^2 \quad (19)$$

D. Generator Outage Contingency Constraints

The following constraints are added to the model for all generators $n' \in N$ to ensure that thermal and voltage step constraints are met on loss of a generator (here, contingency voltage level constraints are not enforced.) The symbols used are the same as before, except that the contingency power flow variables are indexed by generator outage n' .

1) *Grid Supply Point*: The GSP is a (V, δ) bus which is enforced by the following constraints:

$$\delta_{c,b_{\text{GSP}}} = 0 \quad (20)$$

$$V_{n',b_{\text{GSP}}} = V_{b_{\text{GSP}}} \quad (21)$$

All other buses including load and DG sites are (P, Q) buses.

2) *Kirchhoff voltage law*: The KVL expressions are identical to the base case except that contingency flow and voltage variables are used. As the voltage step is defined before remedial action can be taken, the base case tap ratios τ_t are used.

3) *Kirchhoff current law*: $\forall b \in B$,

$$\sum_{x \in X_b} p_{n',x}^X + \sum_{n \in N_b \neq n'} p_n = \sum_{l \in L} p_{n',b}^{\text{LT}} + d_b^P \quad (22)$$

$$\sum_{x \in X_b} q_{n',x}^X + \sum_{n \in N_b \neq n'} (\tan \phi_n) p_n = \sum_{l \in L} q_{n',b}^{\text{LT}} + d_b^P \quad (23)$$

4) *Flow limit constraints*: These take the same form as the base case lines and transformers apart from the presence of contingency flow variables, e.g.

$$(f_{n',l}^{1,P})^2 + (f_{n',l}^{2,Q})^2 \leq (f_l^+)^2 \quad \forall l \in L \quad (24)$$

Here, it is assumed that the contingency thermal limits are the same as those for the intact network but higher emergency ratings can be used.

5) *Voltage step constraint*:

$$V_b - V^{S,+} \leq V_{n',b} \leq V_b + V^{S,+} \quad \forall n' \in N, \quad (25)$$

where $V^{S,+}$ is the voltage step limit.

APPENDIX B

TEST NETWORK PARAMETERS [19]

All parameters are in per unit on a 100 MVA base.

A. Loads

Bus	d_b^P	d_b^Q
21	1.626	0.358
23	18.430	4.059
26	0.976	0.215

B. Line Impedances and Thermal Limits (f_l^+)

Line	R_l	X_l	B_c	f_l^+
6 – 7	0.02227	0.04961	0.01125	1.32
6 – 8	0.02186	0.04849	0.01082	1.32
20 – 22	0.33980	0.04849	0	0.19
20 – 24	0.25840	0.45350	0	0.27
24 – 25	0.87170	0.62470	0	0.11

C. Transformer Impedances and Thermal Limits (f_t^+)

Transformer	R_t	X_t	f_t^+
7 – 20	0.00961	0.24533	0.60
8 – 20	0.01069	0.25083	0.60
20 – 21	0	0.625	0.24
20 – 23	0	0.208	0.24
24 – 23	0	0.208	0.24
25 – 26	0	1.0	0.05

ACKNOWLEDGMENT

The authors are grateful for valuable discussions with K. McKinnon and their partners in the AMPeRES project, and to Ye Shouxiang for his efforts in advancing areas of this research in his MSc dissertation.

REFERENCES

- [1] P. Barker and R. De Mello, "Determining the impact of distributed generation on power systems. i. radial distribution systems," *IEEE Power Engineering Society Summer Meeting*, vol. 3, pp. 1645–1656, 2000.
- [2] N. Jenkins, R. Allan, P. Crossley, D. Kirschen, and G. Strbac, *Embedded Generation*. Institution of Electrical Engineers, 2000.
- [3] H. L. Willis and W. G. Scott, *Distributed power generation: planning and evaluation*. Marcel Dekker, 2000.
- [4] A. Girgis and S. Brahma, "Effect of distributed generation on protective device coordination in distribution system," *Large Engineering Systems Conference*, pp. 115–119, 2001.
- [5] C. L. Masters, "Voltage rise: the big issue when connecting embedded generation to long 11 kv overhead lines," *IET Power Eng.*, vol. 16, no. 1, pp. 5–12, Feb 2002.
- [6] R. A. Walling, R. Saint, R. C. Dugan, J. Burke, and L. A. Kojovic, "Summary of distributed resources impact on power delivery systems," *IEEE Trans. Power Delivery*, vol. 23, no. 3, pp. 1636–1644, July 2008.
- [7] G. W. Ault and J. R. McDonald, "Planning for distributed generation within distribution networks in restructured electricity markets," *IEEE Power Engineering Review*, vol. 20, no. 2, pp. 52–54, Feb. 2000.
- [8] R. C. Dugan, T. E. McDermott, and G. J. Ball, "Planning for distributed generation," *IEEE Industry Applications Magazine*, vol. 7, no. 2, pp. 80–88, Mar.-Apr. 2001.
- [9] P. Chiradeja and R. Ramakumar, "An approach to quantify the technical benefits of distributed generation," *IEEE Trans. Energy Convers.*, vol. 19, no. 4, pp. 764–773, Dec. 2004.
- [10] L. F. Ochoa, A. Padilha-Feltrin, and G. P. Harrison, "Evaluating distributed generation impacts with a multiobjective index," *IEEE Trans. Power Delivery*, vol. 21, no. 3, pp. 1452–1458, July 2006.
- [11] —, "Time-series based maximization of distributed wind power generation integration," *IEEE Trans. Energy Convers.*, vol. 23, no. 3, pp. 968–974, Sept 2008.
- [12] C. Wang and M. Hashem Nehrir, "Analytical approaches for optimal placement of distributed generation sources in power systems," *IEEE Trans. Power Syst.*, vol. 19, no. 4, pp. 2068–2076, Nov. 2004.
- [13] N. Acharya, P. Mahat, and N. Mithulananthan, "An analytical approach for dg allocation in primary distribution network," *Int. J. Electr. Power Energy Syst.*, vol. 28, no. 10, pp. 669–678, Dec. 2006.
- [14] A. Silvestri, A. Berizzi, and S. Buonanno, "Distributed generation planning using genetic algorithms," *Proc. IEEE Power Tech*, pp. 257–1999.
- [15] G. Celli and F. Pilo, "Optimal distributed generation allocation in mv distribution networks," *Proc. 22nd IEEE PES International Conference on Power Industry Computer Applications*, pp. 81–86, 2001.
- [16] L. F. Ochoa, A. Padilha-Feltrin, and G. P. Harrison, "Time-series based maximization of distributed wind power generation integration," *IEEE Trans. on Energy Convers.*, vol. 23, no. 3, pp. 968–974, Sept. 2008.
- [17] A. Keane and M. O'Malley, "Optimal utilization of distribution networks for energy harvesting," *IEEE Trans. Power Syst.*, vol. 22, no. 1, pp. 467–475, Feb. 2007.
- [18] N. S. Rau and Y.-H. Wan, "Optimum location of resources in distributed planning," *IEEE Trans. Power Syst.*, vol. 9, no. 4, pp. 2014–2020, Nov 1994.

- [19] G. P. Harrison and A. R. Wallace, "Optimal power flow evaluation of distribution network capacity for the connection of distributed generation," *Generation, Transmission and Distribution, IEE Proceedings*, vol. 152, no. 1, pp. 115–122, Jan. 2005.
- [20] P. N. Vovos, G. P. Harrison, A. R. Wallace, and J. W. Bialek, "Optimal power flow as a tool for fault level constrained network capacity analysis," *IEEE Trans. Power Syst.*, vol. 20, no. 2, pp. 734–741, May 2005.
- [21] L. F. Ochoa, C. J. Dent, and G. P. Harrison, "Maximisation of intermittent distributed generation in active networks," *Proc. CIRED Seminar: SmartGrids for Distribution*, p. 4, 2008.
- [22] A. Keane and M. O'Malley, "Optimal allocation of embedded generation on distribution networks," *Power Systems, IEEE Transactions on*, vol. 20, no. 3, pp. 1640–1646, Aug. 2005.
- [23] "Planning limits for voltage fluctuations caused by industrial, commercial and domestic equipment in the united kingdom," Electricity Networks Association, Engineering Recommendation P28, 1989.
- [24] "Voltage step changes," minutes of the Energy Networks Association - G59 G75 Working Group (Oct 2007.) Available online at http://www.energynetworks.org/dcode/pdfs/G59G75%20WG%20Proposal%20on%20voltage%20step%20changes_12032007.pdf.
- [25] "Technical guide to the connection of generation to the distribution network," 2003, power Planning Associates, Report to UK Department of Trade and Industry (DTI).
- [26] "Accommodating distributed generation," May 2006, econnect Consulting, Report to UK Department of Trade and Industry (DTI).
- [27] "Recommendations for the connection of embedded generating plant to public distribution systems above 20kv or with outputs over 5mw," Electricity Networks Association, Engineering Recommendation G75/1, 2002.
- [28] R. Dugan, personal communication.
- [29] B. Kuri, M. A. Redfem, and F. Li, "Optimisation of rating and positioning of dispersed generation with minimum network disruption," in *Power Engineering Society General Meeting, IEEE*, vol. 2, 2004.
- [30] K. Nara, Y. Hayashi, K. Ikeda, and T. Ashizawa, "Application of tabu search to optimal placement of distributed generators," *Power Engineering Society Winter Meeting, 2001. IEEE*, vol. 2, pp. 918–923 vol.2, 2001.
- [31] T. W. Eberly and R. C. Schaefer, "Voltage versus var/power-factor regulation on synchronous generators," *Industry Applications, IEEE Transactions on*, vol. 38, no. 6, pp. 1682–1687, Nov/Dec 2002.
- [32] P. N. Vovos, A. E. Kiprakis, A. R. Wallace, and G. P. Harrison, "Centralized and distributed voltage control: Impact on distributed generation penetration," *IEEE Trans. Power. Syst.*, vol. 22, no. 1, pp. 476–483, Feb. 2007.
- [33] P. N. Vovos and J. W. Bialek, "Direct incorporation of fault level constraints in optimal power flow as a tool for network capacity analysis," *IEEE Trans. Power. Syst.*, vol. 20, no. 4, pp. 2125–2134, Nov. 2005.
- [34] G. P. Harrison, A. Piccolo, P. Siano, and A. R. Wallace, "Hybrid ga and opf evaluation of network capacity for distributed generation connections," *Electric Power Systems Research*, vol. 78, 2008.
- [35] B. Stott, O. Alsac, and A. J. Monticelli, "Security analysis and optimization," *Proceedings of the IEEE*, vol. 75, no. 12, pp. 1623–1644, Dec. 1987.
- [36] Electricity Networks Association, Engineering Recommendation P2/6: 'Security of Supply', 2006.
- [37] J. Bisschop and M. Roelofs, *AIMMS - The User's Guide*, Paragon Decision Technology, 2006.
- [38] J. Kallrath, Ed., *Modeling Languages in Mathematical Optimization*. Kluwer Academic Publishers, 2004.
- [39] C. J. Dent, L. F. Ochoa, G. P. Harrison, and J. W. Bialek, "Efficient secure OPF for new generation uptake maximisation," 16th Power Systems Computation Conference, Glasgow, 2008.
- [40] "The Electricity Safety, Quality and Continuity Regulations 2002," available from The Stationary Office or at <http://www.opsi.gov.uk/si/si2002/20022665.htm>.
- [41] P. N. Vovos and J. W. Bialek, "Combinational mechanism for generation capacity and network reinforcement planning," *IET Gener. Transm. Distrib.*, vol. 1, no. 2, pp. 303 – 311, March 2007.



Chris Dent (M'08) is a Research Fellow in the School of Engineering at the University of Edinburgh, U.K. He obtained his B.A. degree in Mathematics from Cambridge University in 1997, PhD in Theoretical Physics from Loughborough University in 2001, and MSc in Operational Research from the University of Edinburgh in 2006. His current research interests lie in efficient algorithms for large scale optimal power flows, network generation capacity assessment, and network reliability assessment.

Dr. Dent is a Chartered Physicist and a member of the Institute of Physics, the Institution of Engineering and Technology, and the Operational Research Society.



Luis F. Ochoa (S'01, M'07) received the graduate from the National Engineering University (UNI), Lima, Peru, in 2000. He obtained the M.Sc. and Ph.D. degrees from Sao Paulo State University (UNESP), Ilha Solteira, Brazil, in 2003 and 2006 respectively.

He is currently a Research Fellow in the Institute for Energy Systems, School of Engineering, University of Edinburgh, U.K. His current research interests include distribution system analysis and distributed generation.

Dr. Ochoa is a member of the Institution of Engineering and Technology (IET) and CIGRE.



Gareth P. Harrison (M'02) is a Senior Lecturer in Energy Systems in the School of Engineering, University of Edinburgh, U.K. His research interests include network integration of distributed generation and analysis of the impact of climate change on the electricity industry.

Dr. Harrison is a Chartered Engineer and member of the Institution of Engineering and Technology.